



INSTALLATION INSTRUCTIONS

**To suit Nissan NP300 Navara Face
Lift Dual Cab MY21.5**



INSTALLATION TIME: 2 Hours (Approximately)

| | | | | |
|--|---|--|--|--|
| IMPORTANT | <ul style="list-style-type: none"> • Do not stand/sit or rest heavy objects on Roll R Cover • Humans or animals are not to be under the closed cover at any given time • Tonneau Cover is not dust or water tight • If contact with volatile chemicals occur, clean Cover with mild detergent and water solution | | | |
| Care Instructions | <ul style="list-style-type: none"> • Read Instructions fully before commencing installation. • Clean Cover with a mild detergent and water solution • Do not use abrasive cleaners or solvents • Refer to manufactures instructions applicable to power drill. • Protect Tub floor against scratches during installation process. | | | |
| Maintenance | Refer to Maintenance instructions. | | | |
| Tools Required | <table style="width: 100%; border: none;"> <tr> <td style="vertical-align: top;"> <ul style="list-style-type: none"> • Pen / Marker • Centre Punch • Drill & Drill bits • Caulking Gun • Silicon - Non Acetic </td> <td style="vertical-align: top;"> <ul style="list-style-type: none"> • Scissors & Knife • Spanner & Socket • Tape measure • Holesaw • Filing tool </td> <td style="vertical-align: top;"> <ul style="list-style-type: none"> • Soapy water solution • Allen Key set • Screw driver • Rust Inhibitor • Trim Removal Tool </td> </tr> </table> | <ul style="list-style-type: none"> • Pen / Marker • Centre Punch • Drill & Drill bits • Caulking Gun • Silicon - Non Acetic | <ul style="list-style-type: none"> • Scissors & Knife • Spanner & Socket • Tape measure • Holesaw • Filing tool | <ul style="list-style-type: none"> • Soapy water solution • Allen Key set • Screw driver • Rust Inhibitor • Trim Removal Tool |
| <ul style="list-style-type: none"> • Pen / Marker • Centre Punch • Drill & Drill bits • Caulking Gun • Silicon - Non Acetic | <ul style="list-style-type: none"> • Scissors & Knife • Spanner & Socket • Tape measure • Holesaw • Filing tool | <ul style="list-style-type: none"> • Soapy water solution • Allen Key set • Screw driver • Rust Inhibitor • Trim Removal Tool | | |

PERSONAL PROTECTIVE EQUIPMENT:



Rubber Gloves



Goggles



Hearing Protection

BOX CONTENTS

LEFT & RIGHT SIDE RAIL

S2.5-DC-AE-002ps-NN4 

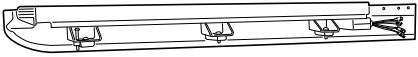
S2.5-DC-AE-003ds-NN4 

CANISTER ASSEMBLY

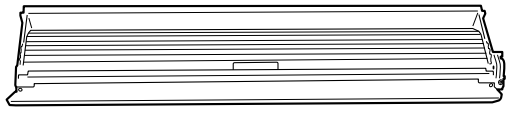

S3-DC-AF-NN4R-001-002

CANISTER TOP COVER

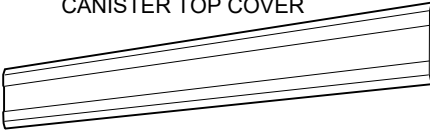

S2.5-DC-AE-005 -NN4

TOP COVER END CAPS

 S2.5-DC-PI-004ps

 S2.5-DC-PI-004ds



COUNTERSUNK
SCREW Qty - 4



FLAT PLATE
Qty- 2



50449 D-SPONGE
Qty-2



ASSEMBLY BAR



BATTERY
LOOM S2.75



CL-LOOM-SHORT



NN-PATCH-K



CABLE TIE
Qty x 16



M8 x 20
ALLEN Head
Bolt Qty - 6

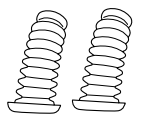

Drainage pipe
Qty - 2

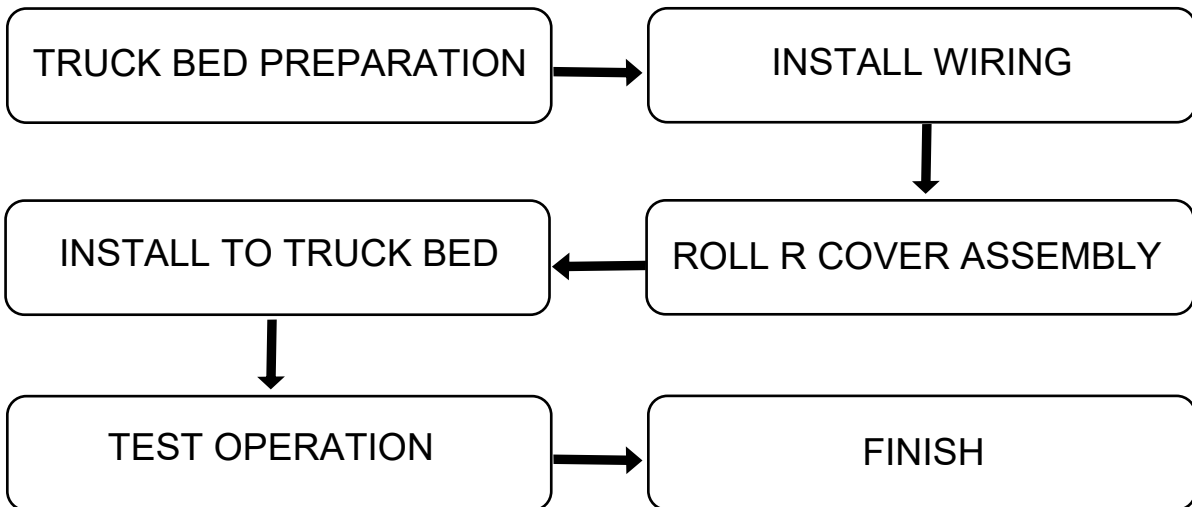

TUB PREPARATION

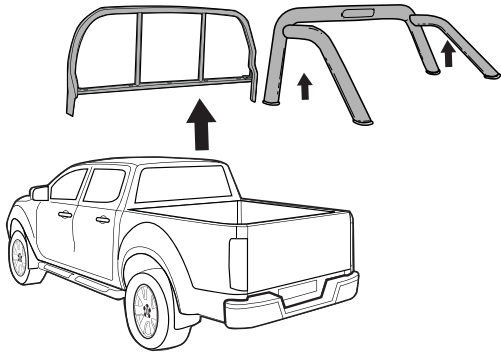

If the Vehicle is fitted with a cabin guard or sports styling bar, remove from Ute Tub (truck bed).

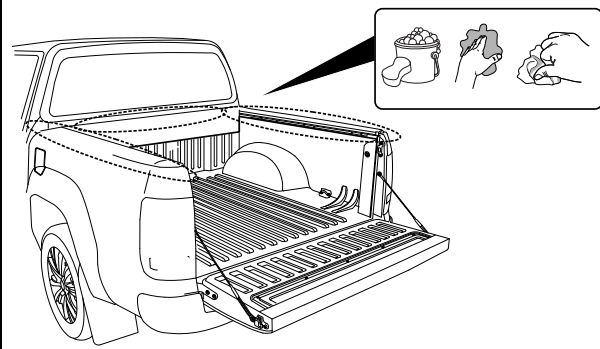

Clean area as indicated.

1. Unfasten and retain 4 factory bolts as indicated.
2. Remove factory grommet (left and right grommet and discard).

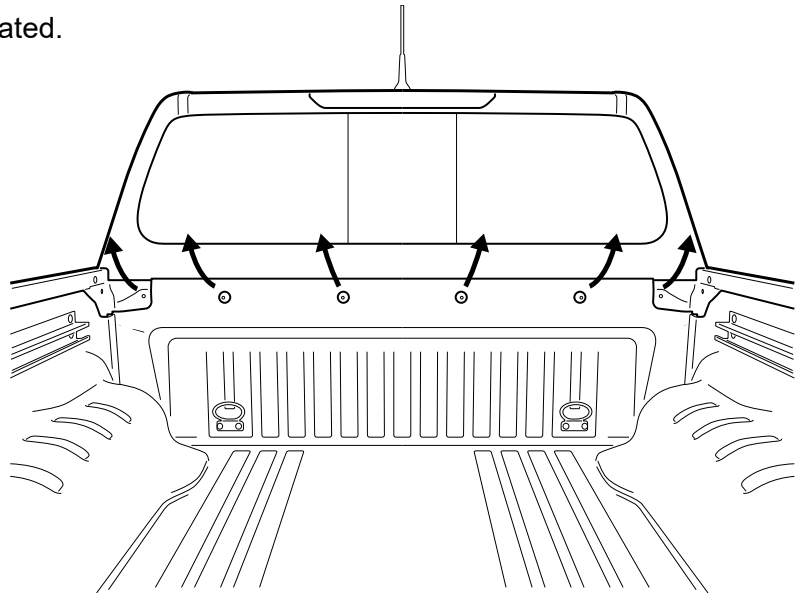

Measure 10mm down from top of tailgate and trim tailgate liner.

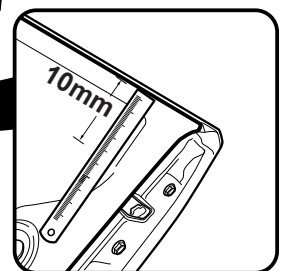
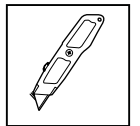
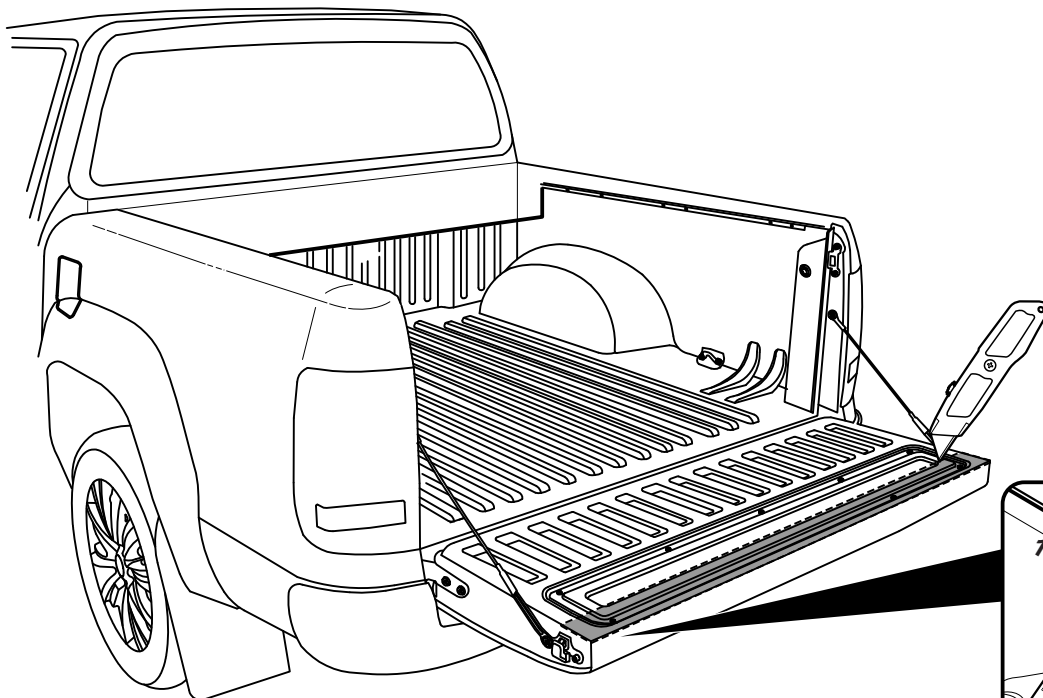

Measure down from top of assembly bar 230mm & 170 mm from inside wall of bed liner as shown. Repeat to the other side. Using a 50mm hole-saw drill the liner only as indicated.

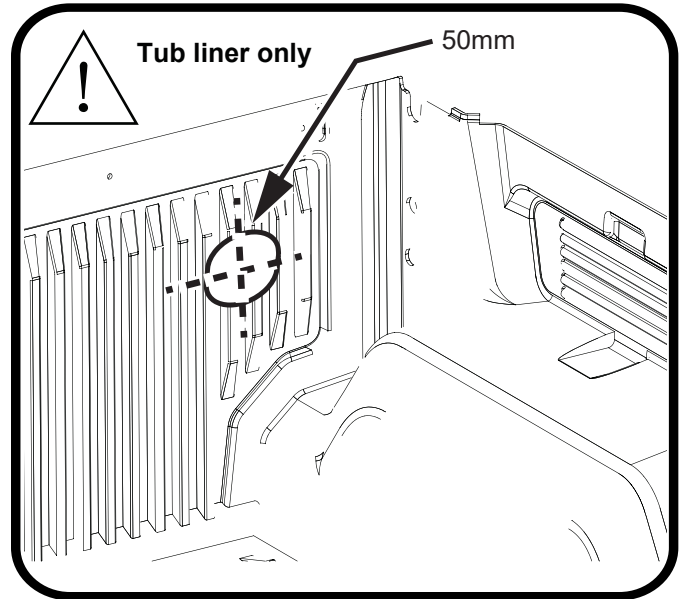
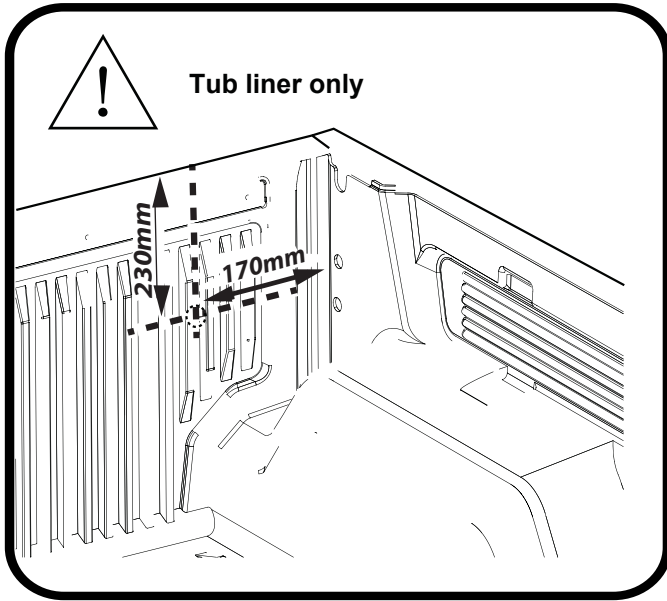
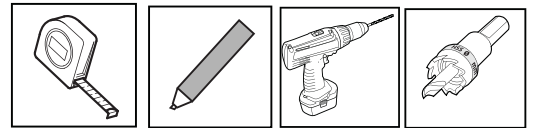

Measure down from top of headboard 230mm & 170mm from inside wall of bed as shown. Repeat to the other side. Using a 30mm hole-saw drill through tub front panel, file away any sharp edges. Apply anti rust coating. Repeat to other side.

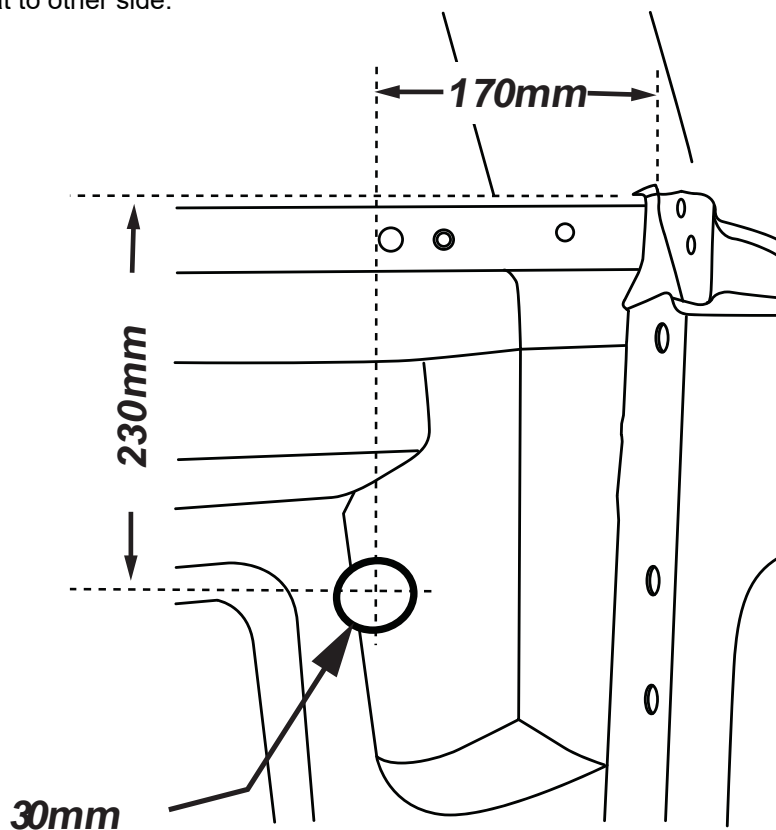
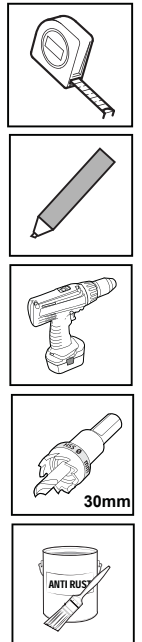

! ATTENTION: Do not exceed 30mm hole.

Seal any exposed gaps or holes on the front panel of the Ute bed with sealant.

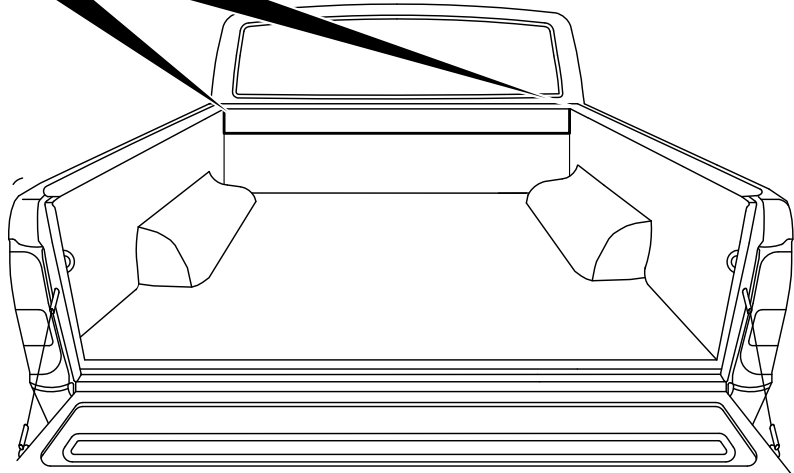
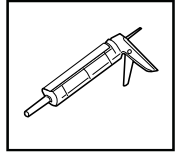
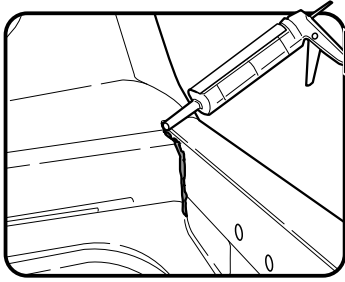

Carefully unpack the box.

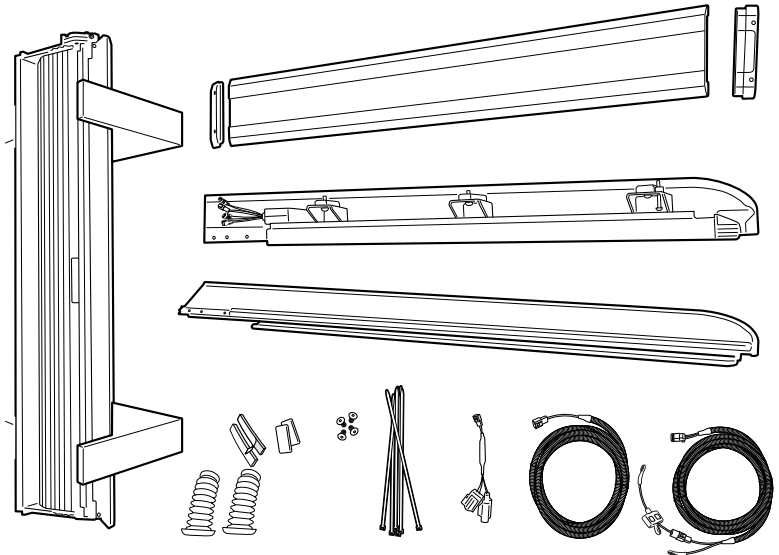
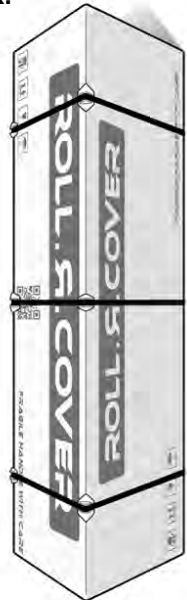

Install front drain pipes (55mm diameter end of hose) through pre-drilled holes on the front tub panel.



Note: With care push tube in.
Taking care pull the tube back so it seals correctly against the front panel of the tub.

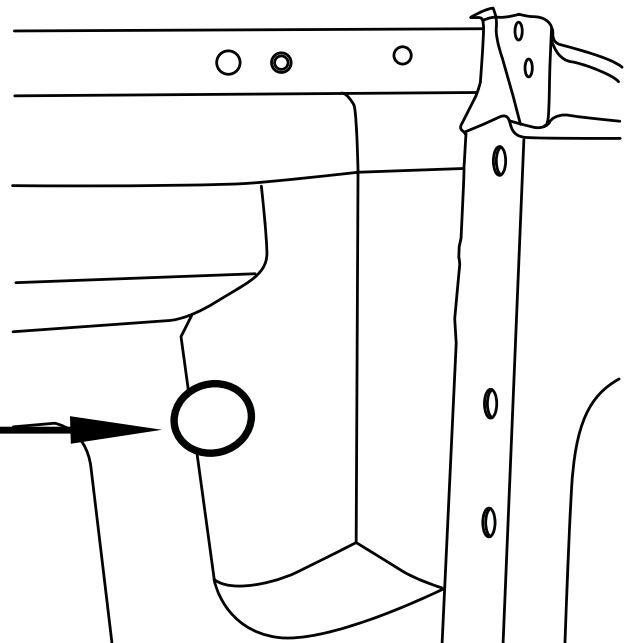
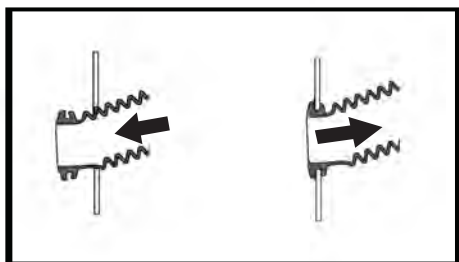

Disconnect fuse patch from battery loom S2.75.

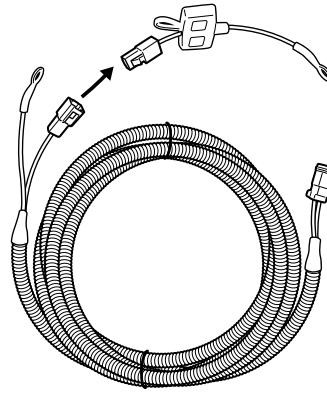

Wiring Harness steps

1 Feed Battery Loom S2.75 through the cavity

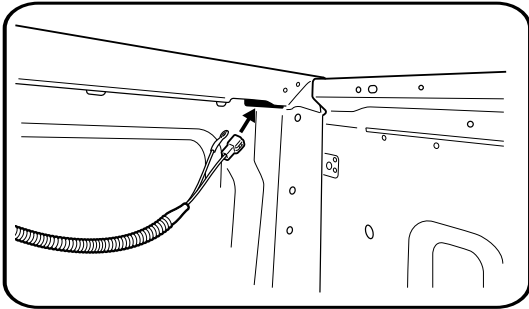

3

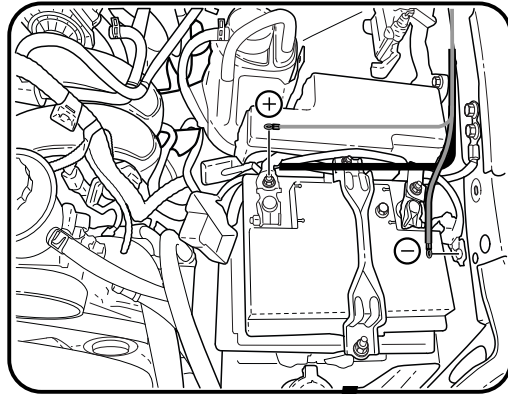

2

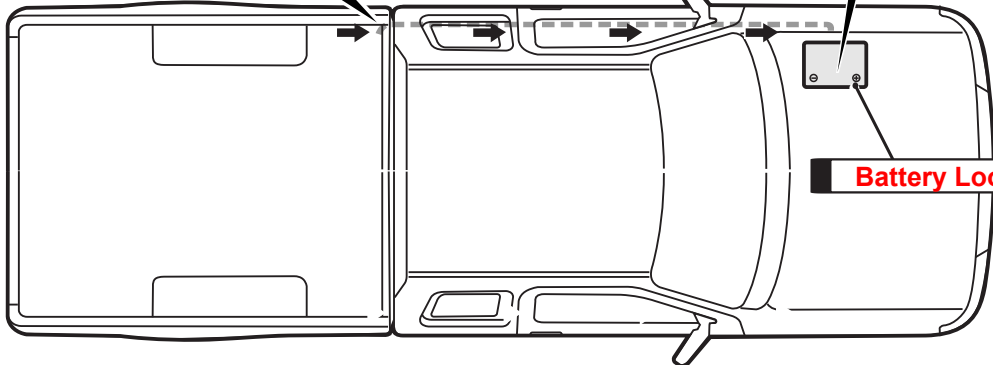

Run the wiring from the front corner cavity (leaving 200mm in the tub) to the battery over the chassis rail. Making sure to keep away from hot obstructions and cable tie every 400mm. Reconnect fuse patch to battery loom S2.75, now attach fuse patch to positive of battery and earth to the body of the Ute.

Feed CL-Short-Loom through the cavity.

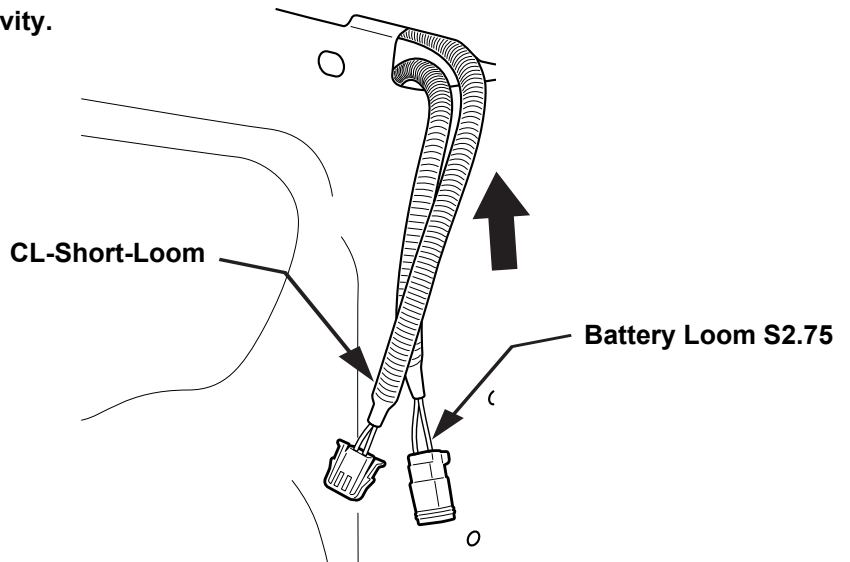

Place Front bar assembly to head board and line up with factory threads. Note: If tub is fitted with factory liner, place Front bar assembly between head board and liner. Fasten using factory bolts where possible. M8 bolts are provided in the kit where needed.

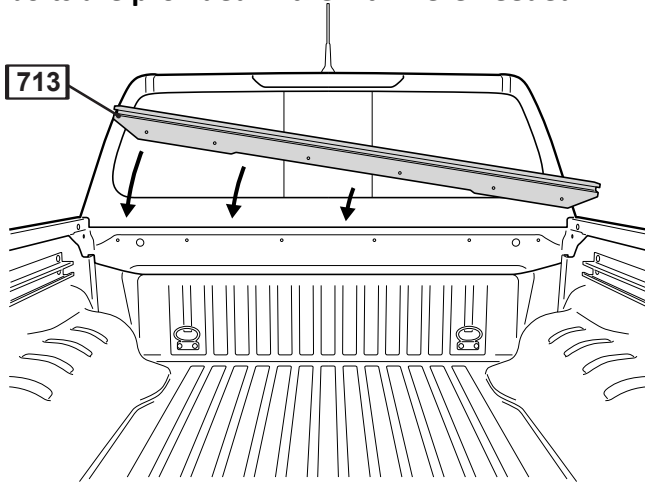

Fasten in to position using the 6 qty. M8 x 20mm bolt.

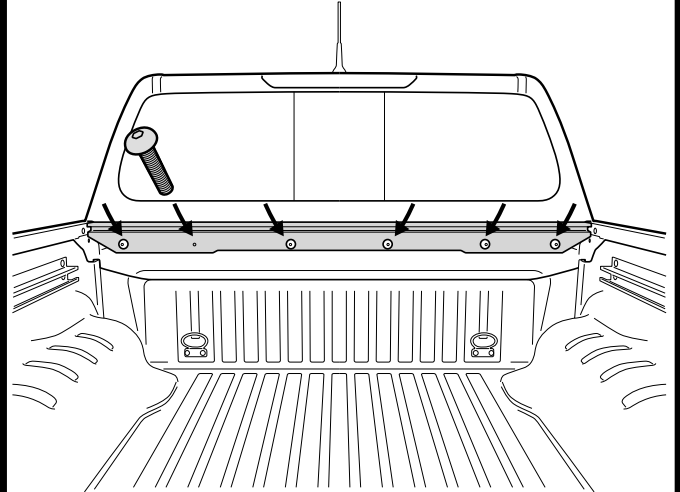

Remove required clips and cover to gain access to fuel flap actuator loom.

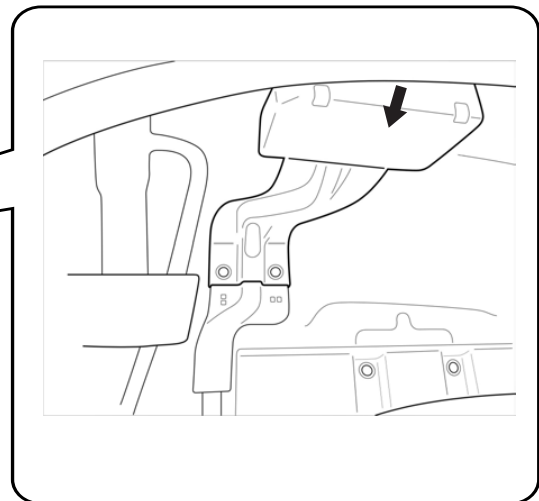
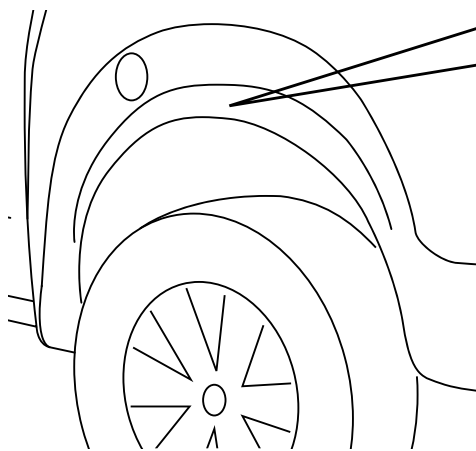

- 1) Plug NN-PATCH wiring.
- 2) Plug CL-LOOM-SHORT wiring.

Cable tie overhang of wiring and place the cover removed earlier.

Re-fit fuel cap wiring cover.

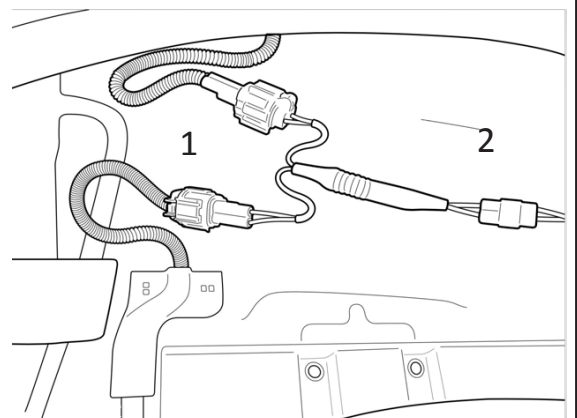

keep the cannister in the foam blocks from the packaging for assembly.

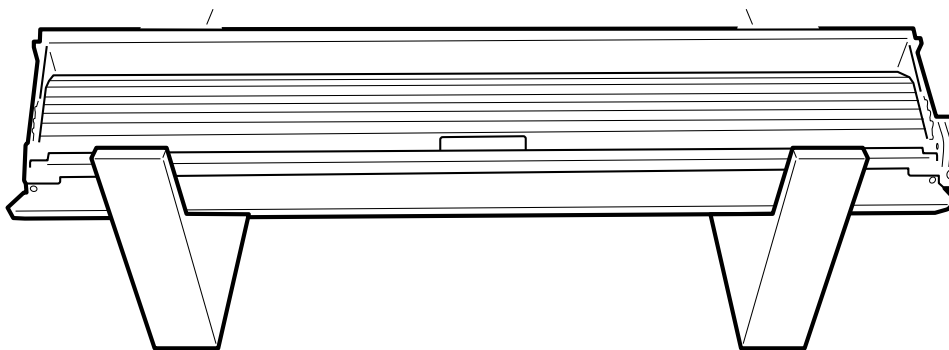
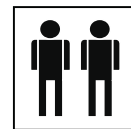

With assistance turn the canister on its back on the foam blocks.

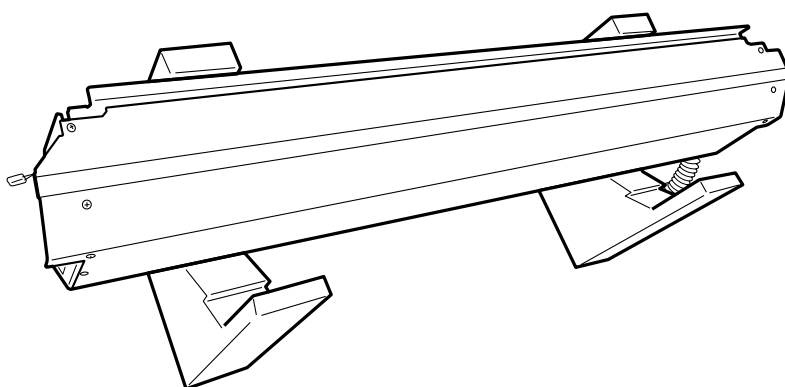

Disengage motor from the axle by unfastening the 3 Screw as indicated. Retain all parts.

Remove and retain the 3 screw from the canister as indicated.

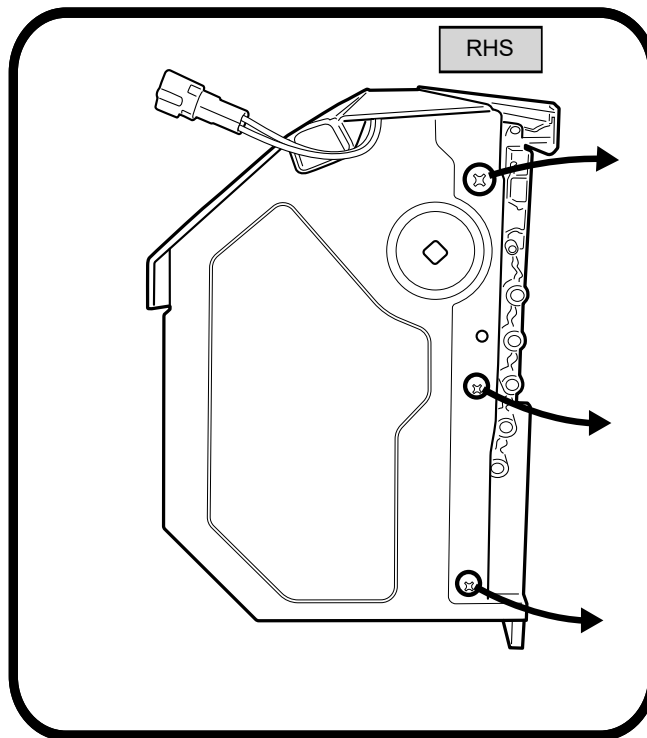
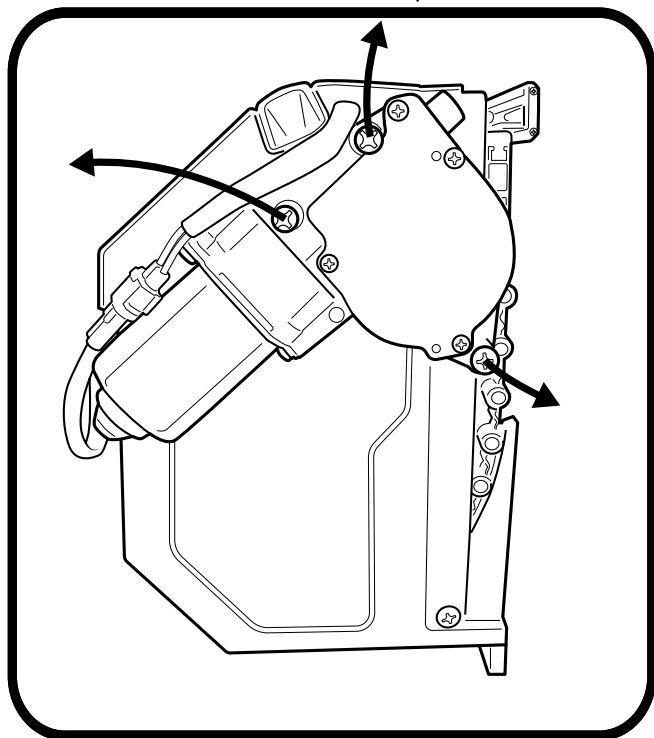
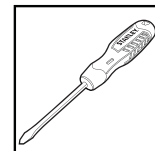

Now on the other side, remove and retain the 4 screws from the canister as indicated.

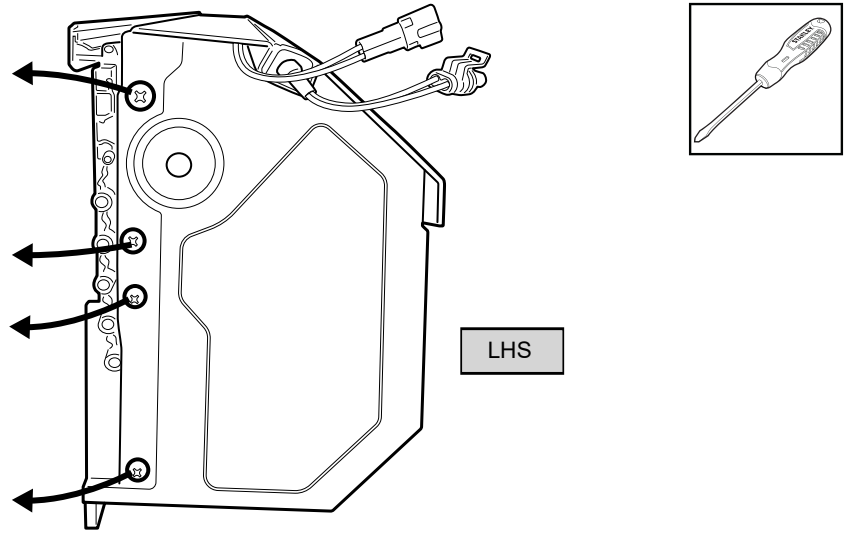

Align side rail to side of canister, guide the track to go in between the curtain end rubber stop.

NOTE: LHS side rail to be assembled first.

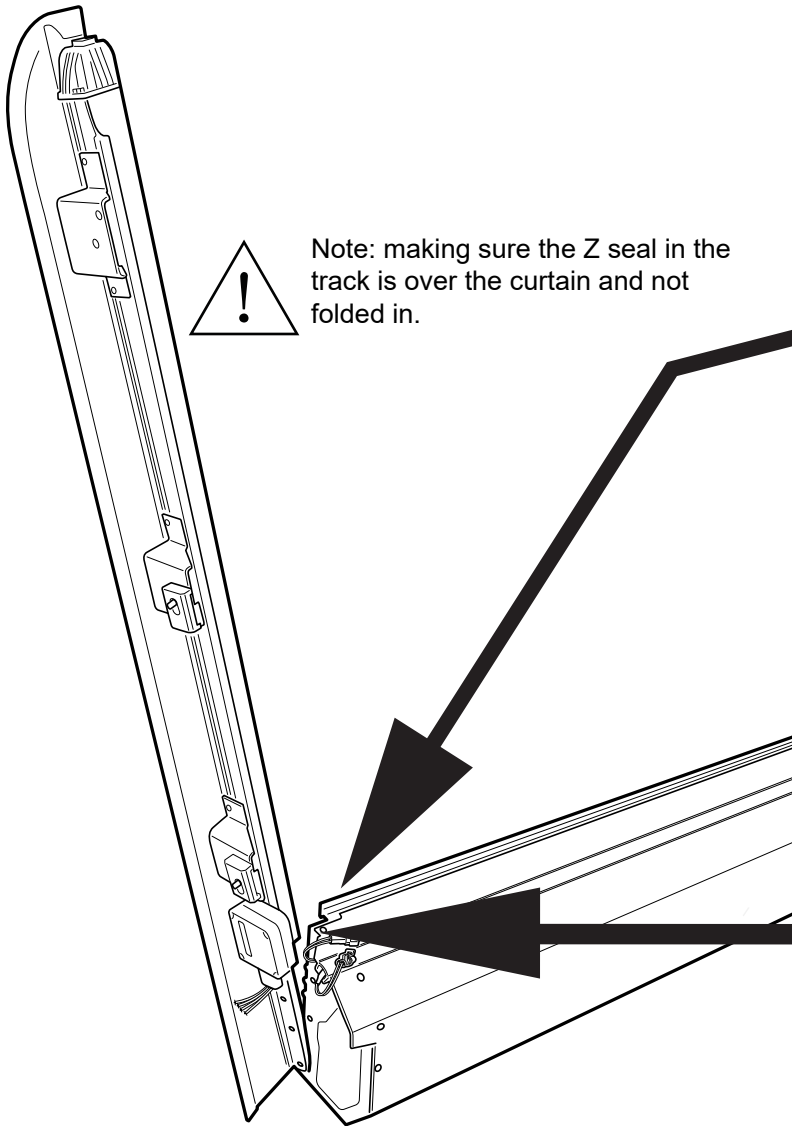

Note: making sure the Z seal in the track is over the curtain and not folded in.

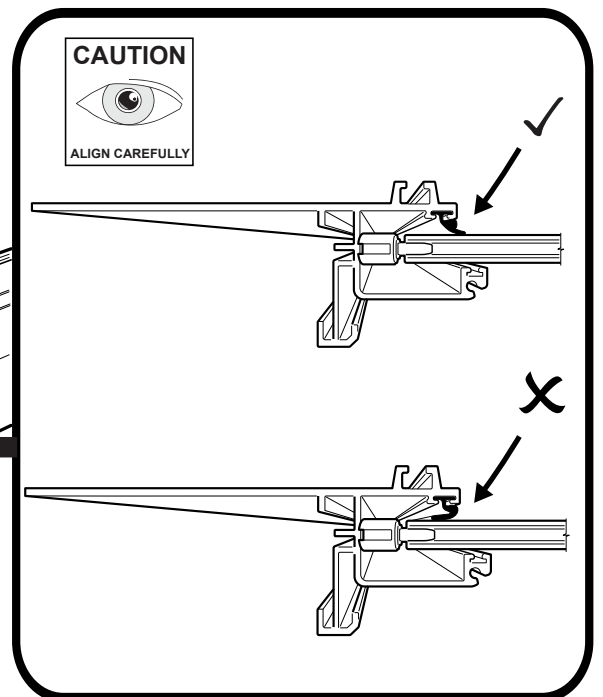
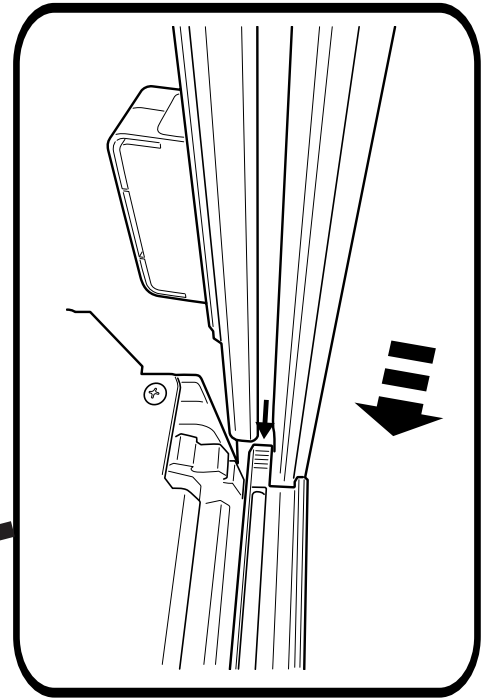

Fasten the side rail using the retained screws.

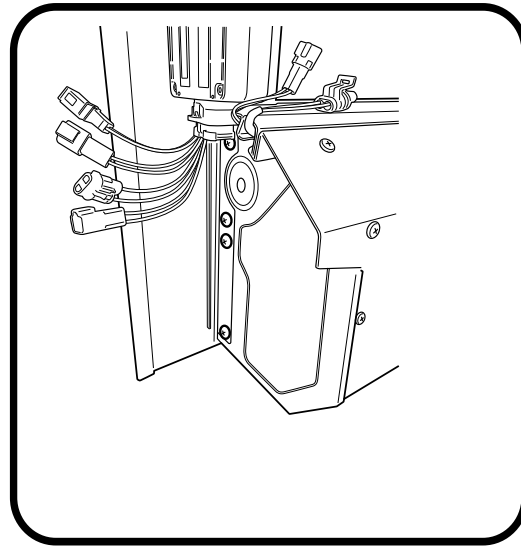
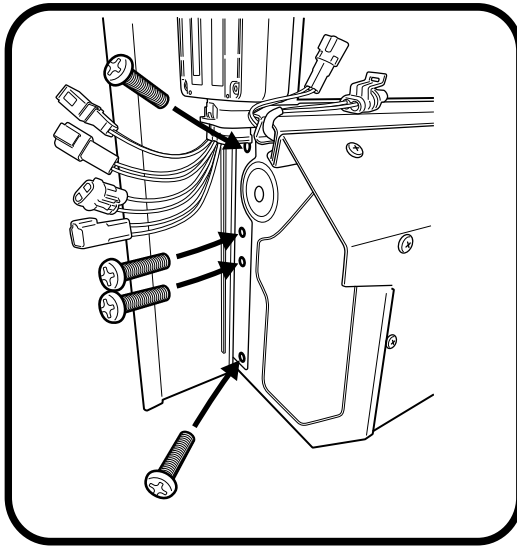
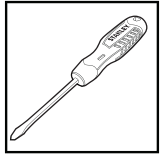

Connect motor connector to receiver

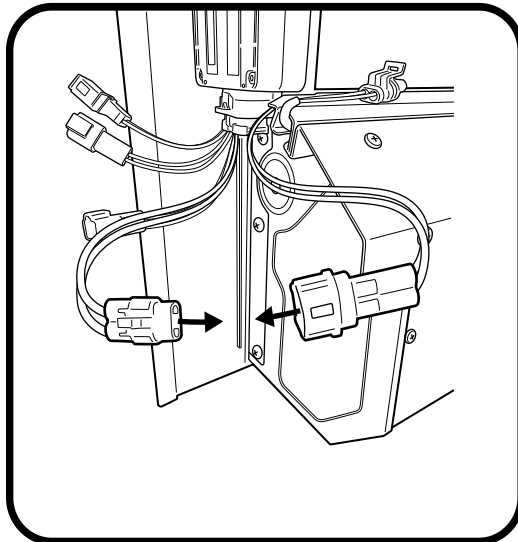

Connect LED Loom to receiver

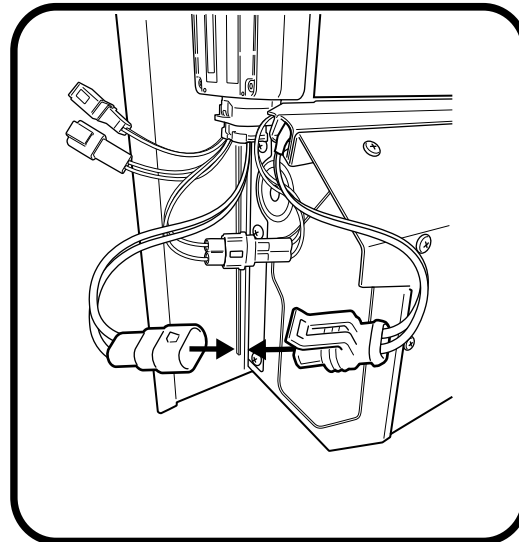

Align side rail to side of canister, guide the track to go in between the curtain end robber stop.

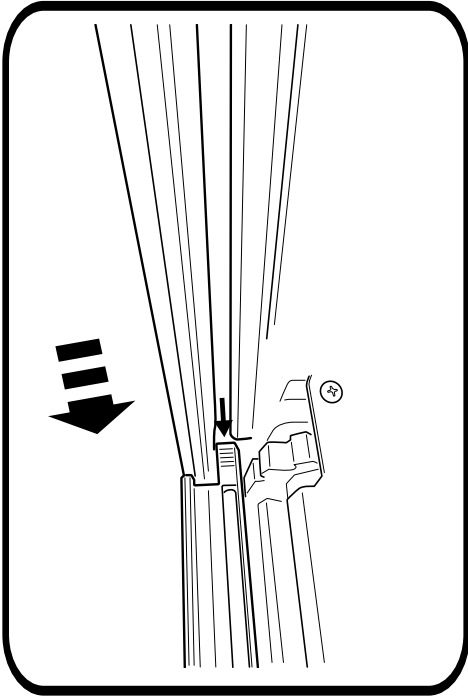

Note: making sure the Z seal in the track is over the curtain and not folded in.

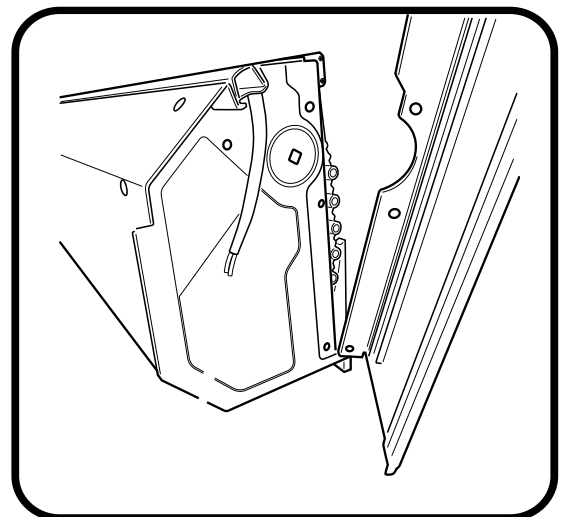
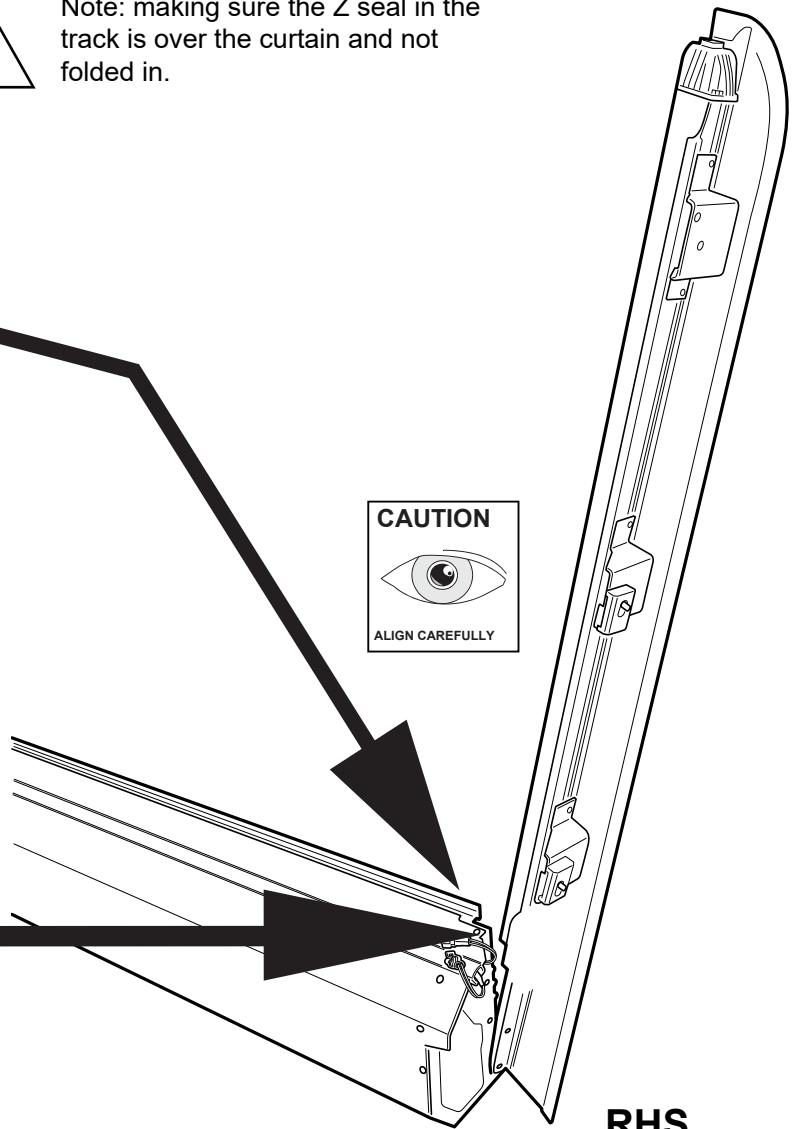
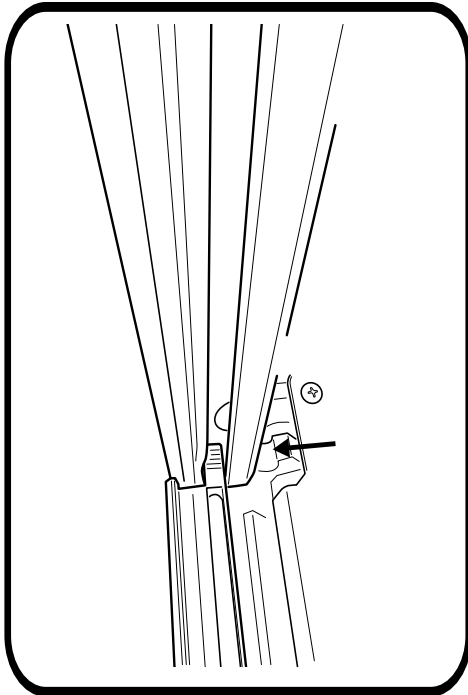

Fasten the side rail using the retained screws only to the locations indicated.

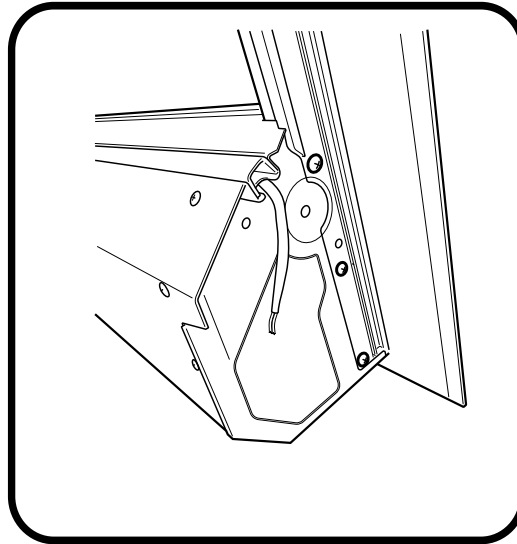
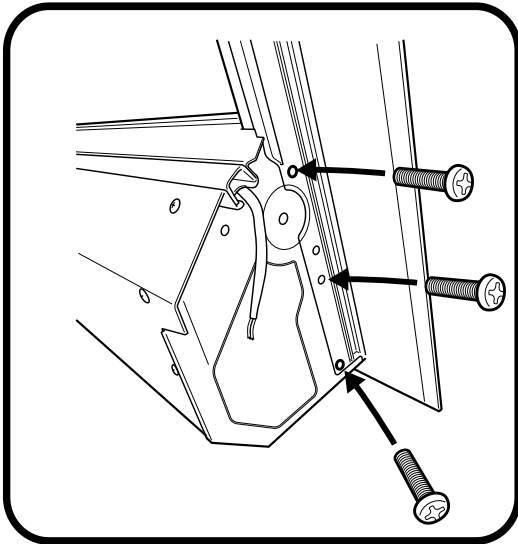
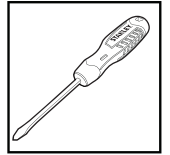

Align & insert motor to the axle.

Pull Curtain out if required to align motor with thread and loosely fasten with retained screw.

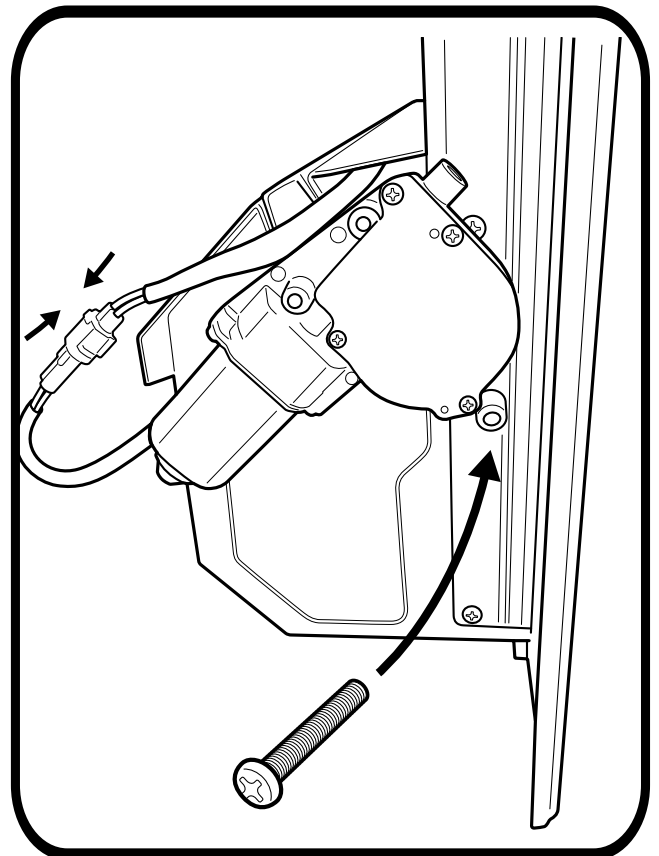
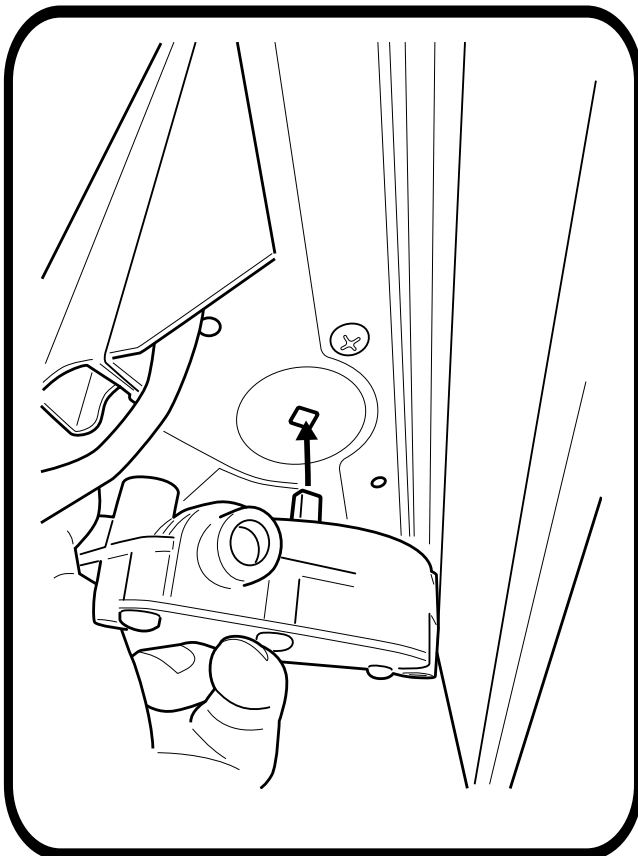
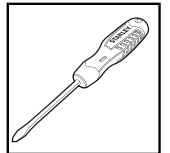

Loosely fasten with retained screws.

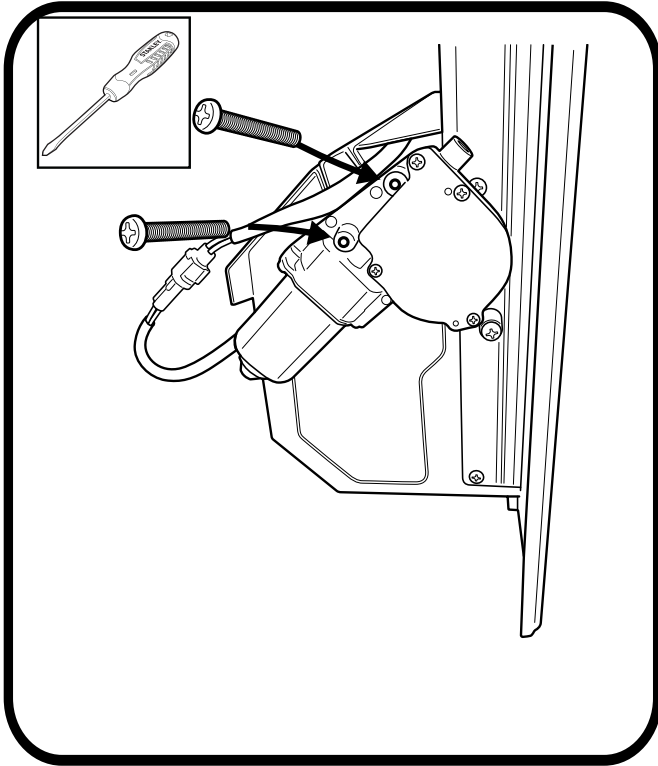

Fasten all 3 screws tight.

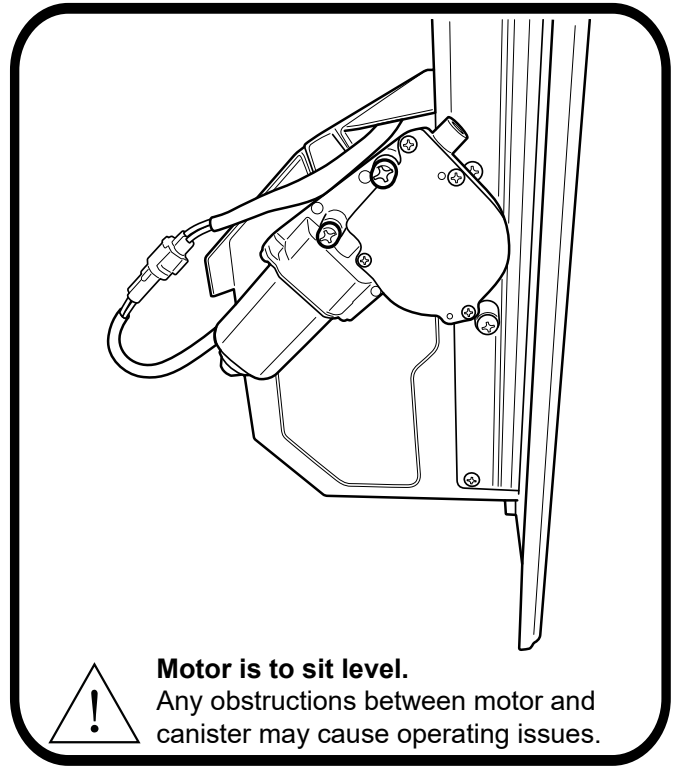

Apply D-sponge foam tape to side rail as indicated. NOTE: Join foam firmly to the per-fitted foam of the canister. Carefully trim excess off & discard as indicated. Repeat on the other side.

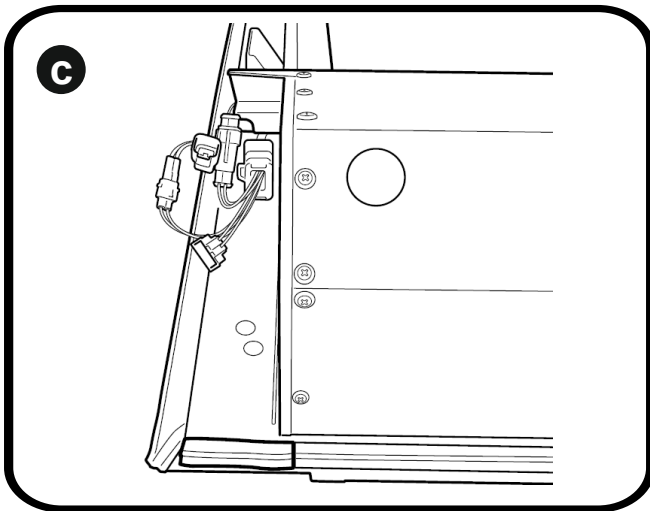
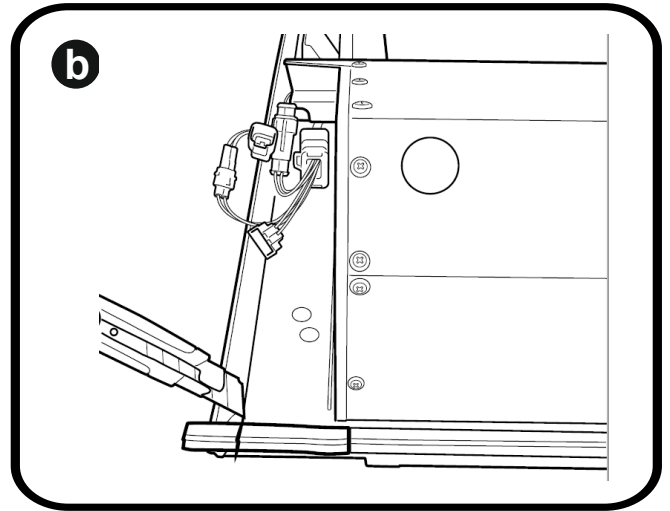
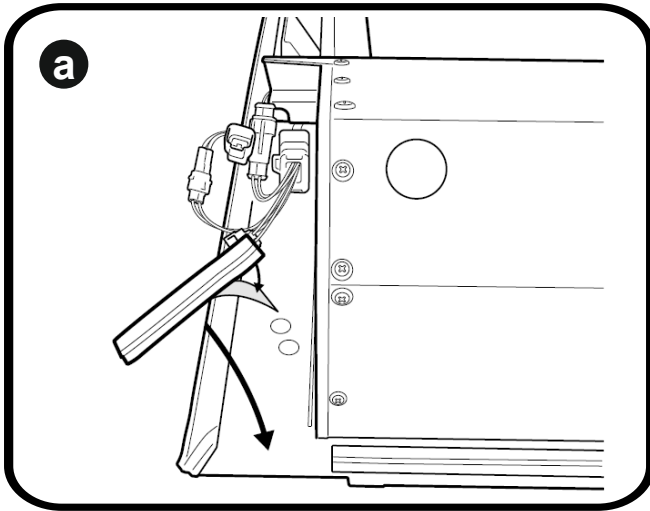

Carefully bring down the assembled unit .
Then unfasten the clamps from the left & right side rails - retain clamps & hardware.

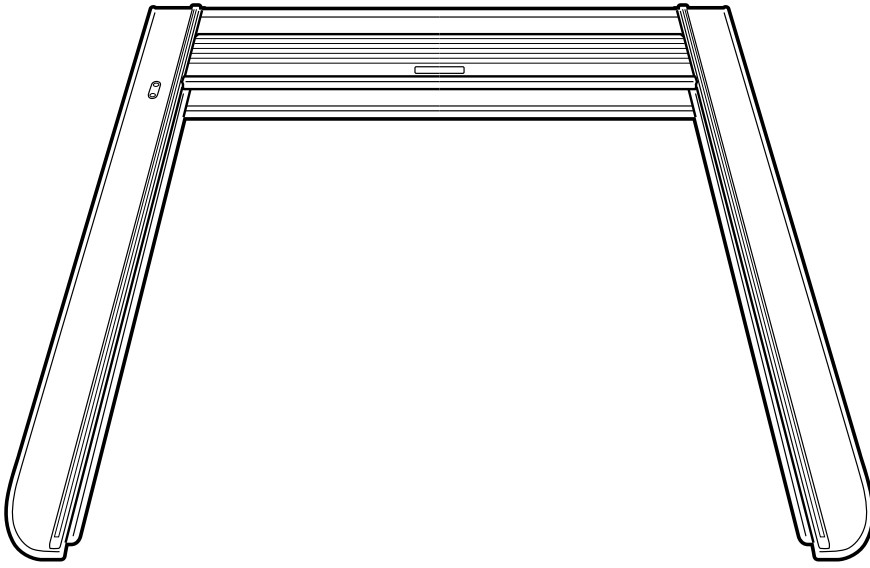
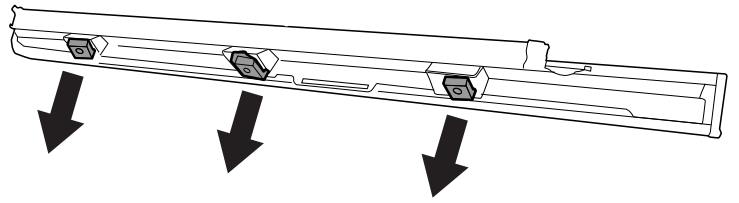

Insert side end caps to the top cover.

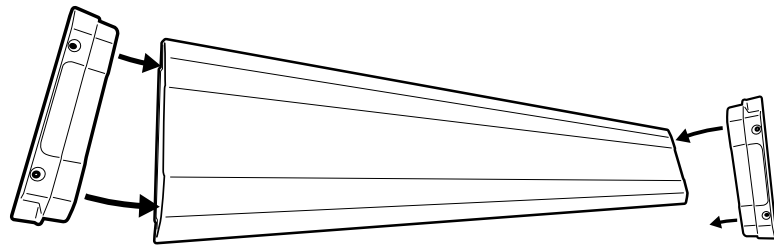

Place & Align top cover over the
canister and side rails.

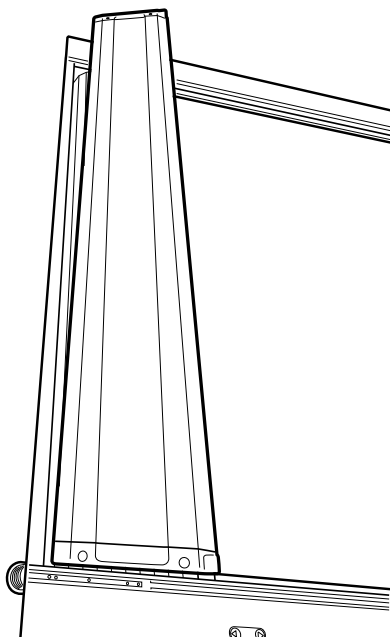

Using countersunk screws provided, line up end cap
holes to the threads on the side rail.
Fasten to 3nm torque. Repeat to the other side.

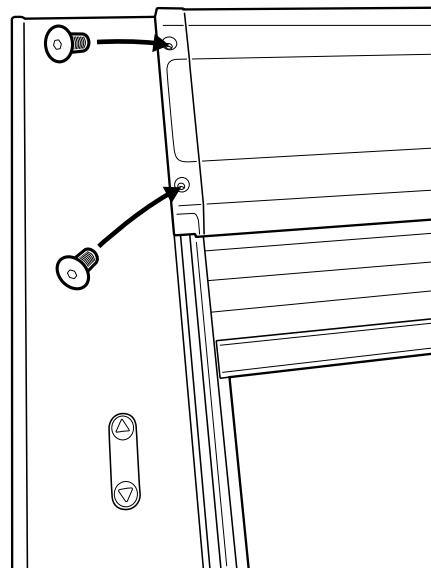

Place the Roll-R-Cover unit on to Ute bed.

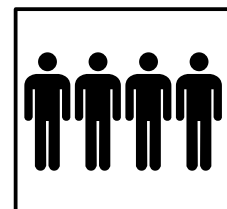
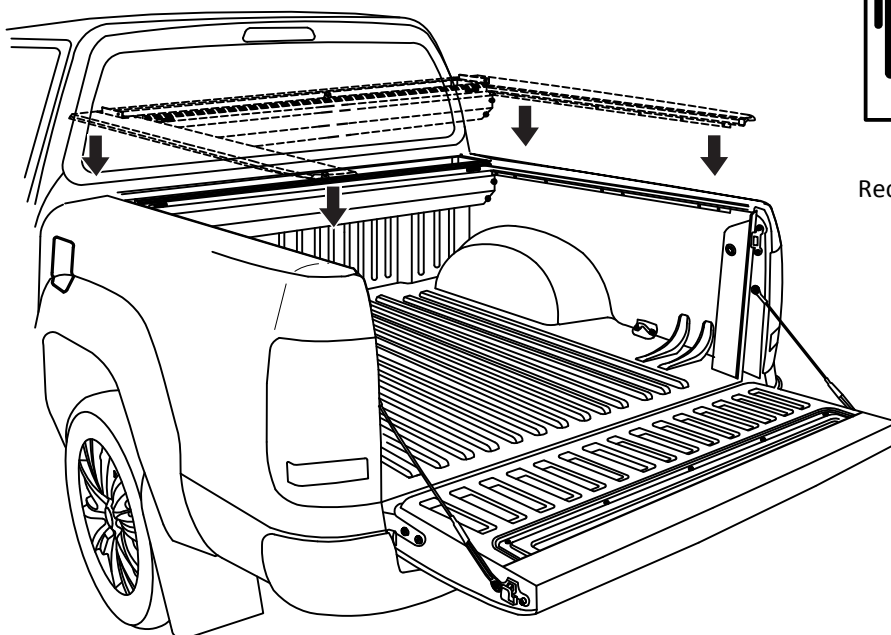

4 People
Recommended for lift

With care, pull out any side rubber that has folded under the side rail.

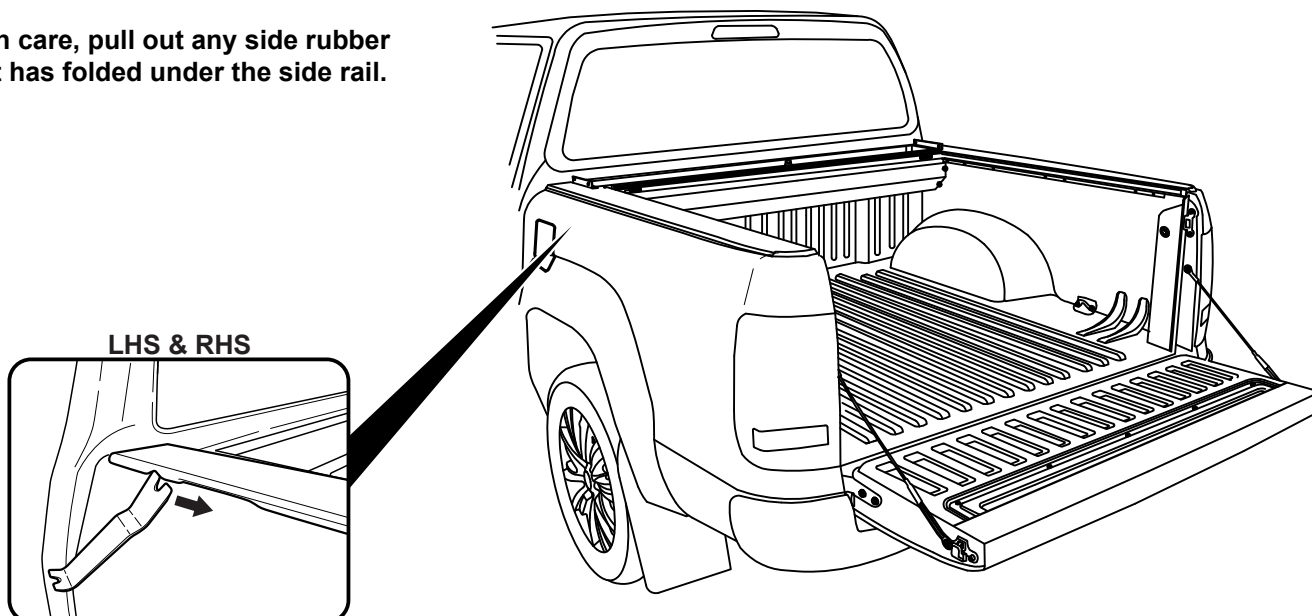

With the tailgate up (Closed position), Pull left & right hand side rails towards the tailgate, stopping short by 5mm between tailgate and side-rail end-cap.

5mm

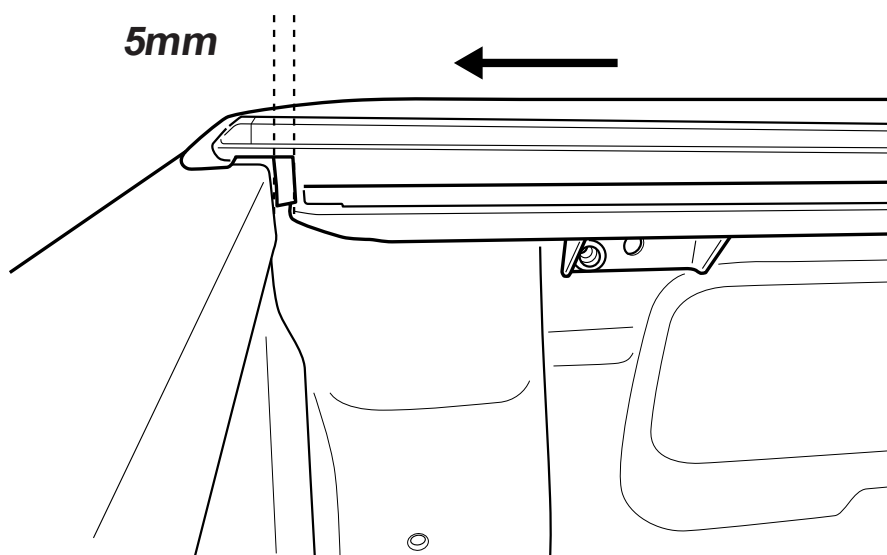

Foam compressed to 5mm when tailgate is closed.

Gap between tailgate and side-rail end cap to be 5mm.

Foam seal

Side rail end cap

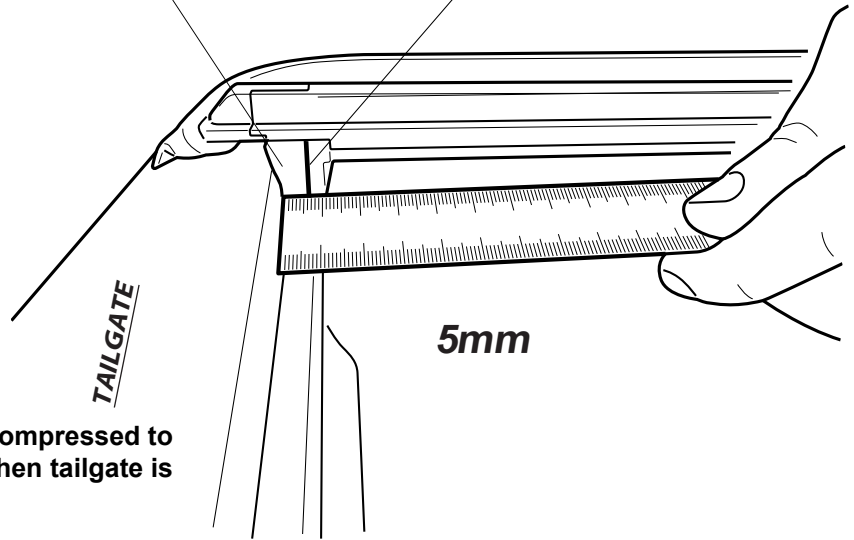

Foam compressed to 5mm when tailgate is closed.

Position clamp behind the inner top lip of the bed rail and the side rail mounting brackets. Repeat to all 6 positions.

Ensure the M8 nyloc nut is in indicated slot of the clamp

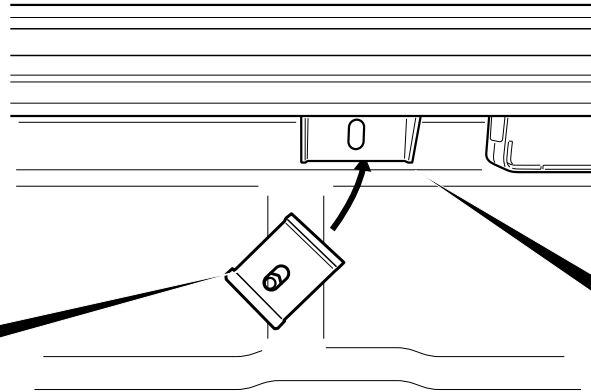
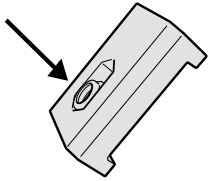

Fasten clamp loosely into position using retained M8 washer and bolt.

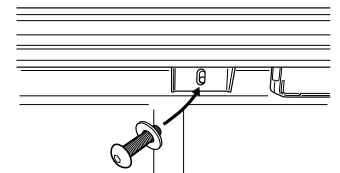

Apply pressure then tighten clamps in the order indicated.

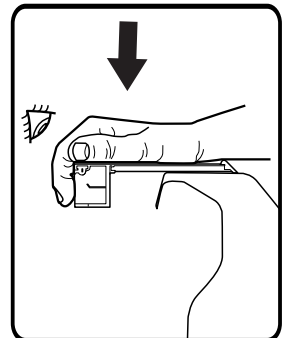
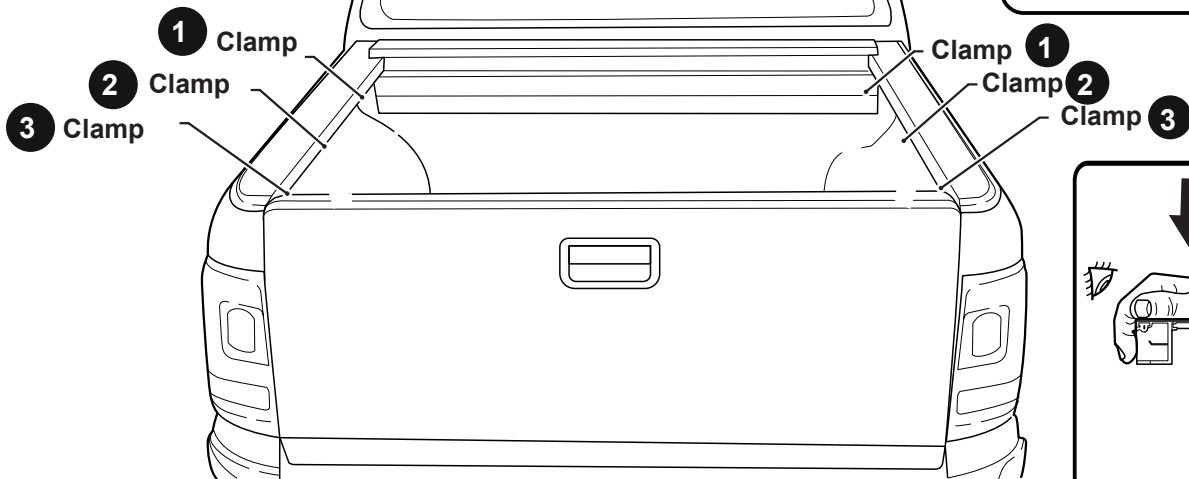
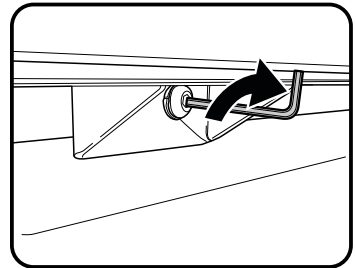

Apply flat plate behind adjusting bolt hole to the ute bed panel or to the liner if the Ute is equipped with a tub liner.

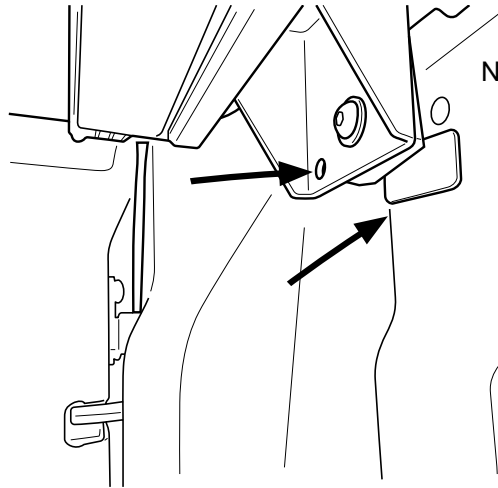

Note: Rear Clamp bracket.



Note: Clean surface before applying flat plate.

Feed M8 bolt through clamp bracket's pre-installed nutsurt as indicated (keeping M8 nut on the bolt thread).

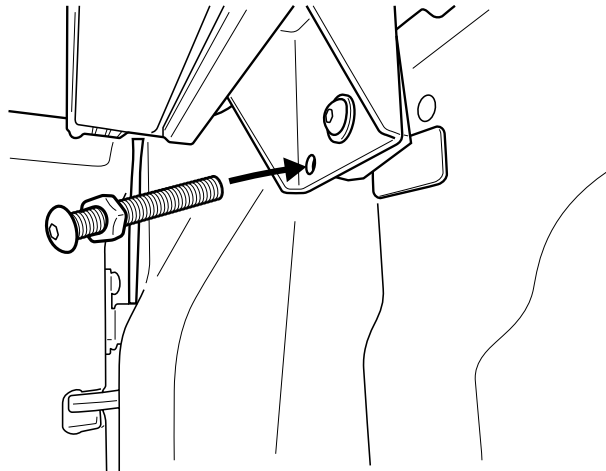

Side rail rubber must have a 1mm gap from the top of the tailgate in the closed position.

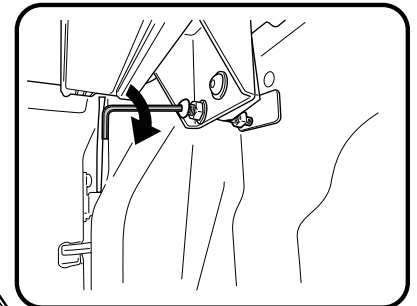
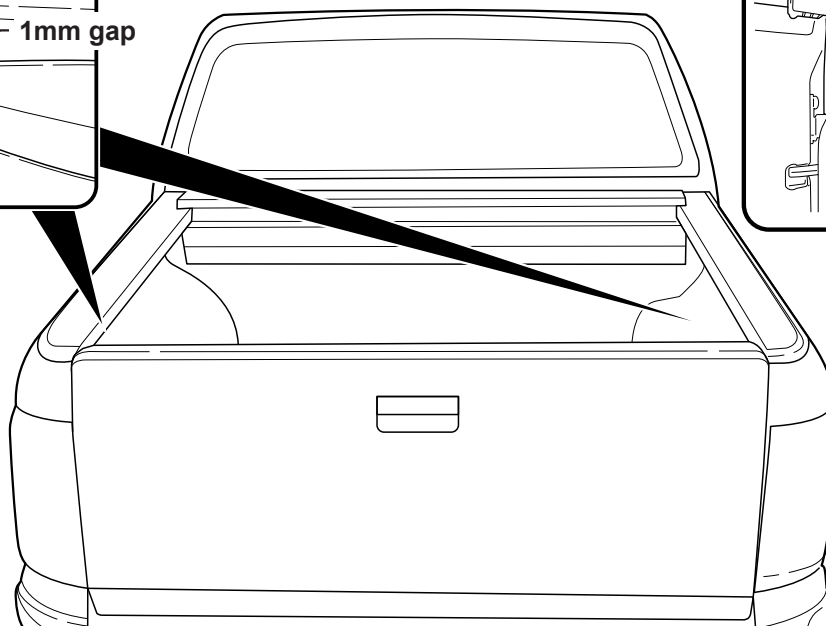
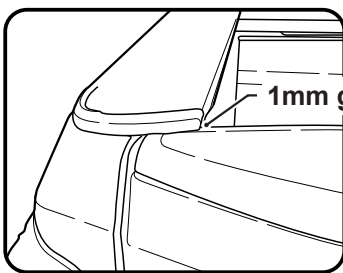

Drive the adjustment bolt in to lift the rear of the side rail till it clears the tailgate.

Fasten the M8 nut against clamp bracket.

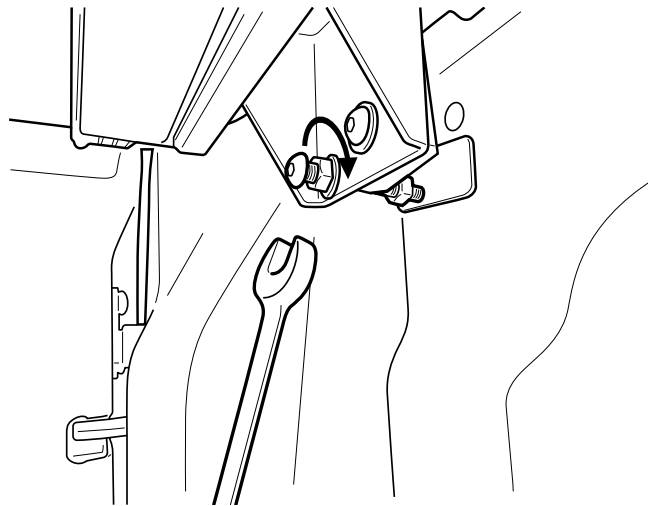

Install front drain pipes through pre-drilled holes of the canister. (RHS/LHS)



Note: With care push tube in.
Taking care pull the tube back
so it seals correctly against
the front panel of the tub.

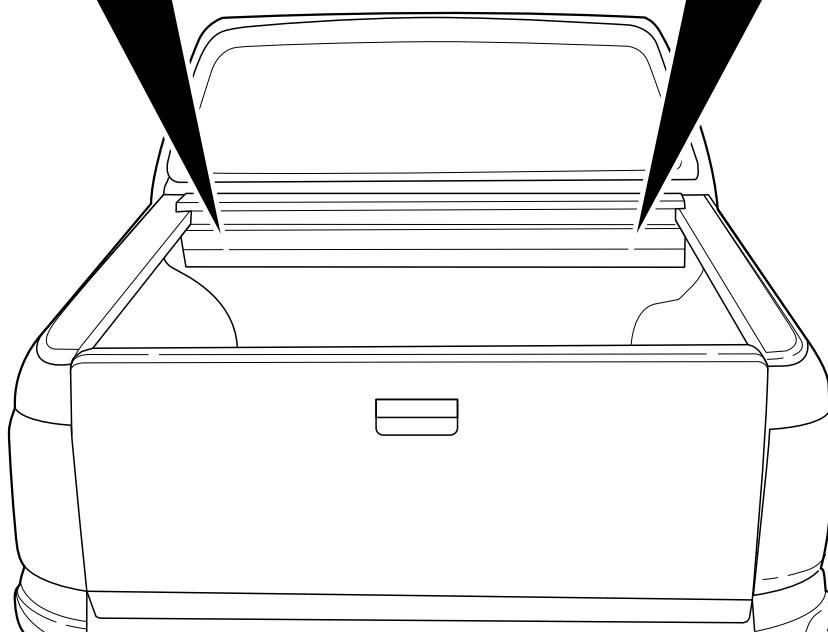
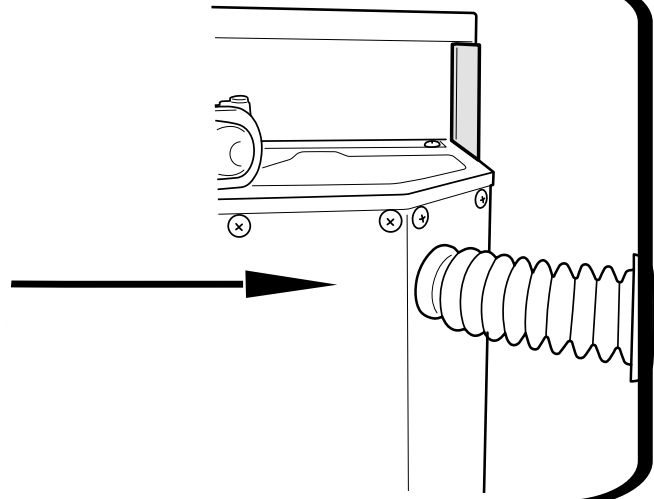
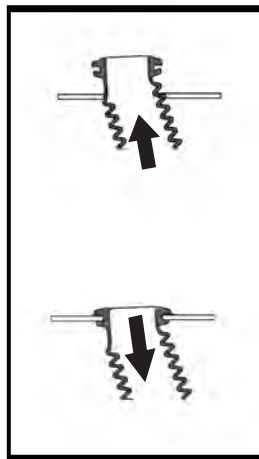

- a. Connect Battery loom S2.75 to Receiver loom.
- b. **Carefully** connect CI-Loom-short to Receiver loom.



Align connectors carefully to avoid pushing pins out.

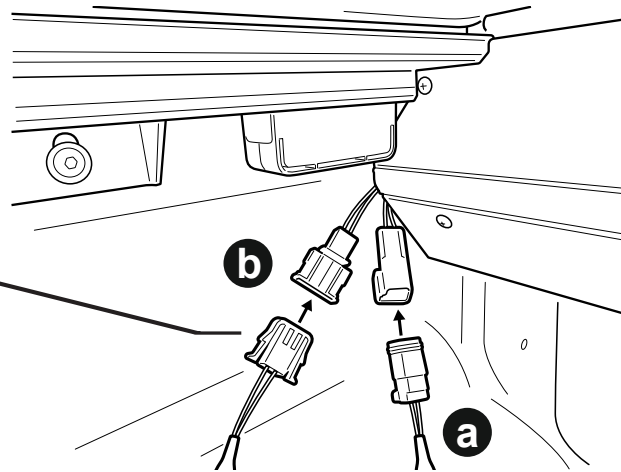

Operating instructions:

Press unlock on vehicle key fob to activate controller.

When vehicle is unlocked the side rail sensor buttons will be active to control.

When vehicle is locked the side rail sensor buttons will be inactive.

Touch & let go to open, touch & let go again to pause.

Touch & let go to close, touch & let go again to pause.

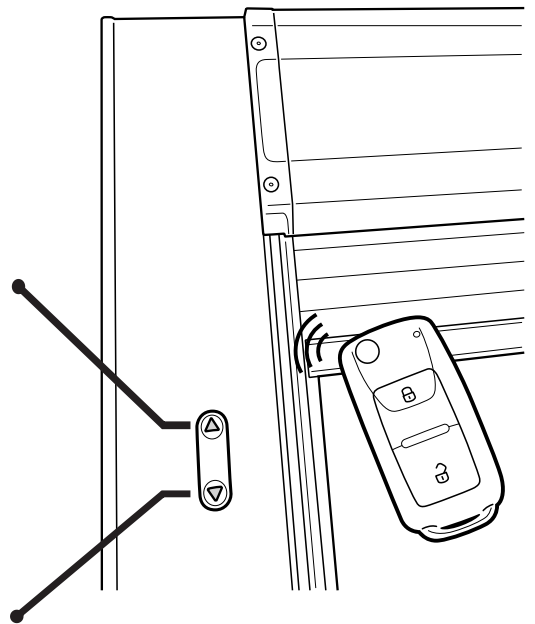

NOTE: 1. To wear in the Roll R Cover please fully open & close the cover approximately 15 times after install is complete.

2. Set your vehicle locking system to unlock all doors with one press of the factory remote unlock button. This setting can be found in your vehicle settings.