



INSTALLATION INSTRUCTIONS

**Vehicle Model: To suit Toyota Hilux Revo
2016+ Dual Cab With Factory Sports Bars**



INSTALLATION TIME: 2 Hours (Approximately)

IMPORTANT	<ul style="list-style-type: none"> • Do not stand/sit or rest heavy objects on Roll R Cover • Humans or animals are not to be under the closed cover at any given time • Tonneau Cover is not dust or water tight • If contact with volatile chemicals occur, clean Cover with mild detergent and water solution 			
Care Instructions	<ul style="list-style-type: none"> • Read Instructions fully before commencing installation. • Clean Cover with a mild detergent and water solution • Do not use abrasive cleaners or solvents • Refer to manufactures instructions applicable to power drill. • Protect Tub floor against scratches during installation process. 			
Maintenance	Refer to Maintenance instructions.			
Tools Required	<table style="width: 100%; border: none;"> <tr> <td style="vertical-align: top;"> <ul style="list-style-type: none"> • Pen / Marker • Centre Punch • Drill & Drill bits • Caulking Gun • Silicon - Non Acetic </td> <td style="vertical-align: top;"> <ul style="list-style-type: none"> • Scissors & Knife • Spanner & Socket • Tape measure • Holesaw • Filing tool </td> <td style="vertical-align: top;"> <ul style="list-style-type: none"> • Soapy water solution • Allen Key set • Screw driver • Rust Inhibitor • Trim Removal Tool </td> </tr> </table>	<ul style="list-style-type: none"> • Pen / Marker • Centre Punch • Drill & Drill bits • Caulking Gun • Silicon - Non Acetic 	<ul style="list-style-type: none"> • Scissors & Knife • Spanner & Socket • Tape measure • Holesaw • Filing tool 	<ul style="list-style-type: none"> • Soapy water solution • Allen Key set • Screw driver • Rust Inhibitor • Trim Removal Tool
<ul style="list-style-type: none"> • Pen / Marker • Centre Punch • Drill & Drill bits • Caulking Gun • Silicon - Non Acetic 	<ul style="list-style-type: none"> • Scissors & Knife • Spanner & Socket • Tape measure • Holesaw • Filing tool 	<ul style="list-style-type: none"> • Soapy water solution • Allen Key set • Screw driver • Rust Inhibitor • Trim Removal Tool 		

PERSONAL PROTECTIVE EQUIPMENT:



Rubber Gloves



Goggles



Hearing Protection

BOX CONTENTS

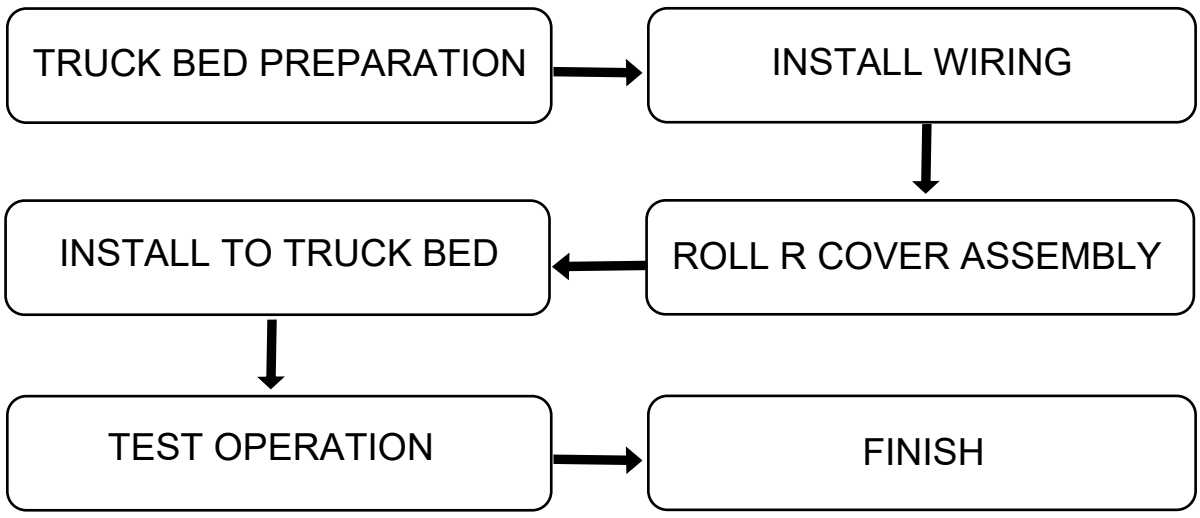
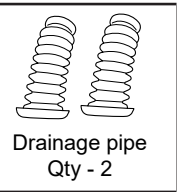
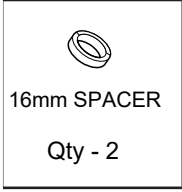
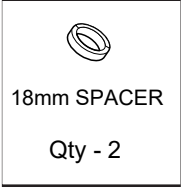
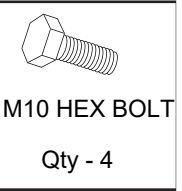
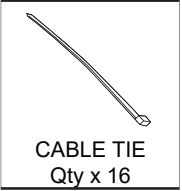
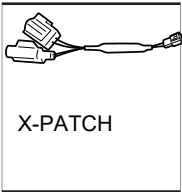
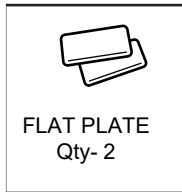
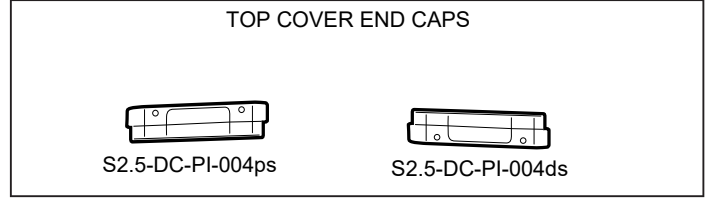
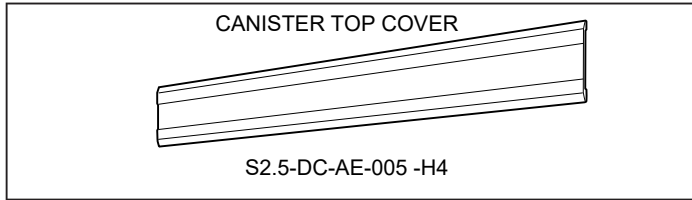
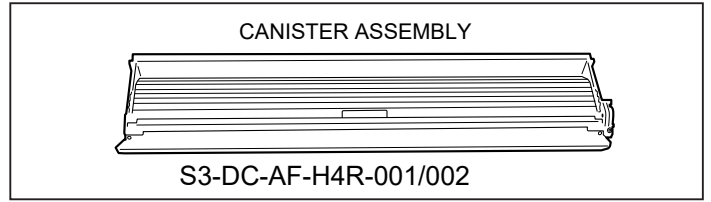
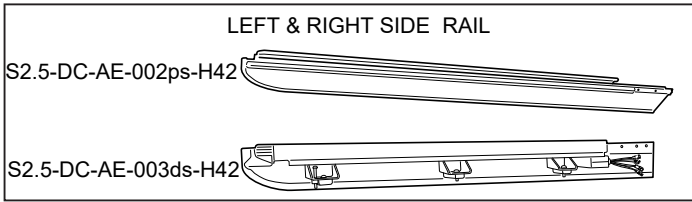

TUB PREPARATION

If the Vehicle is fitted with a cabin guard or sports styling bar, remove from Ute Tub (truck bed).

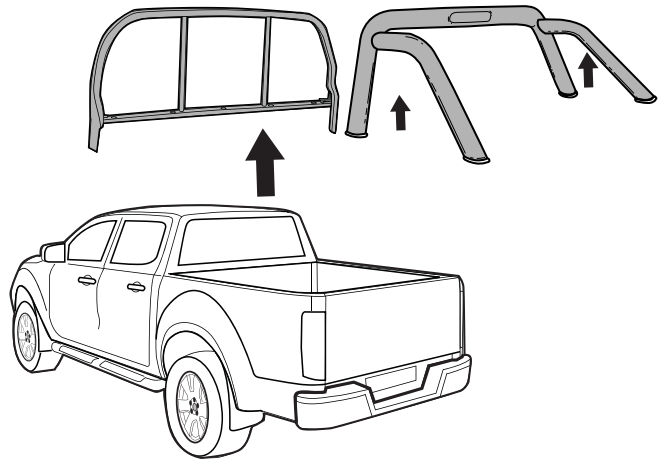

Clean are as indicated.

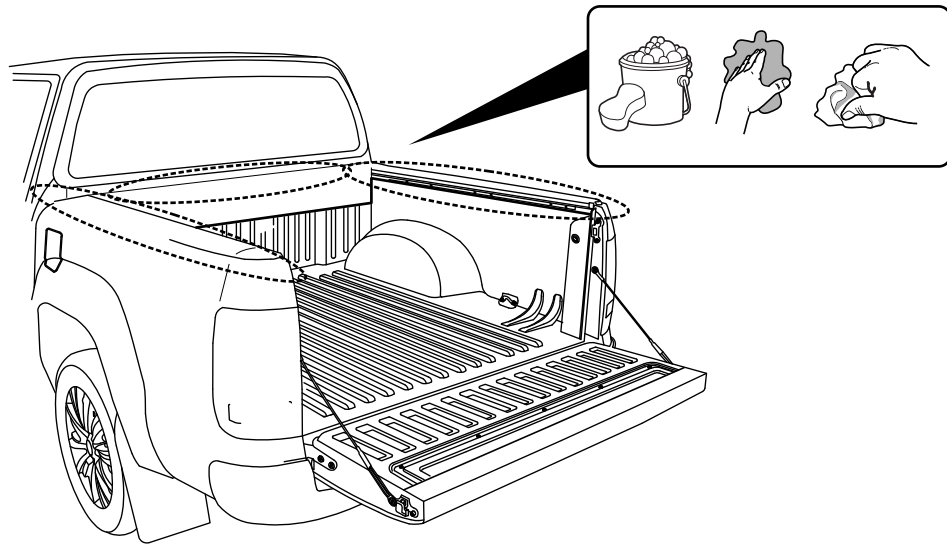

Measure 10mm down from top of tailgate and trim tailgate liner.

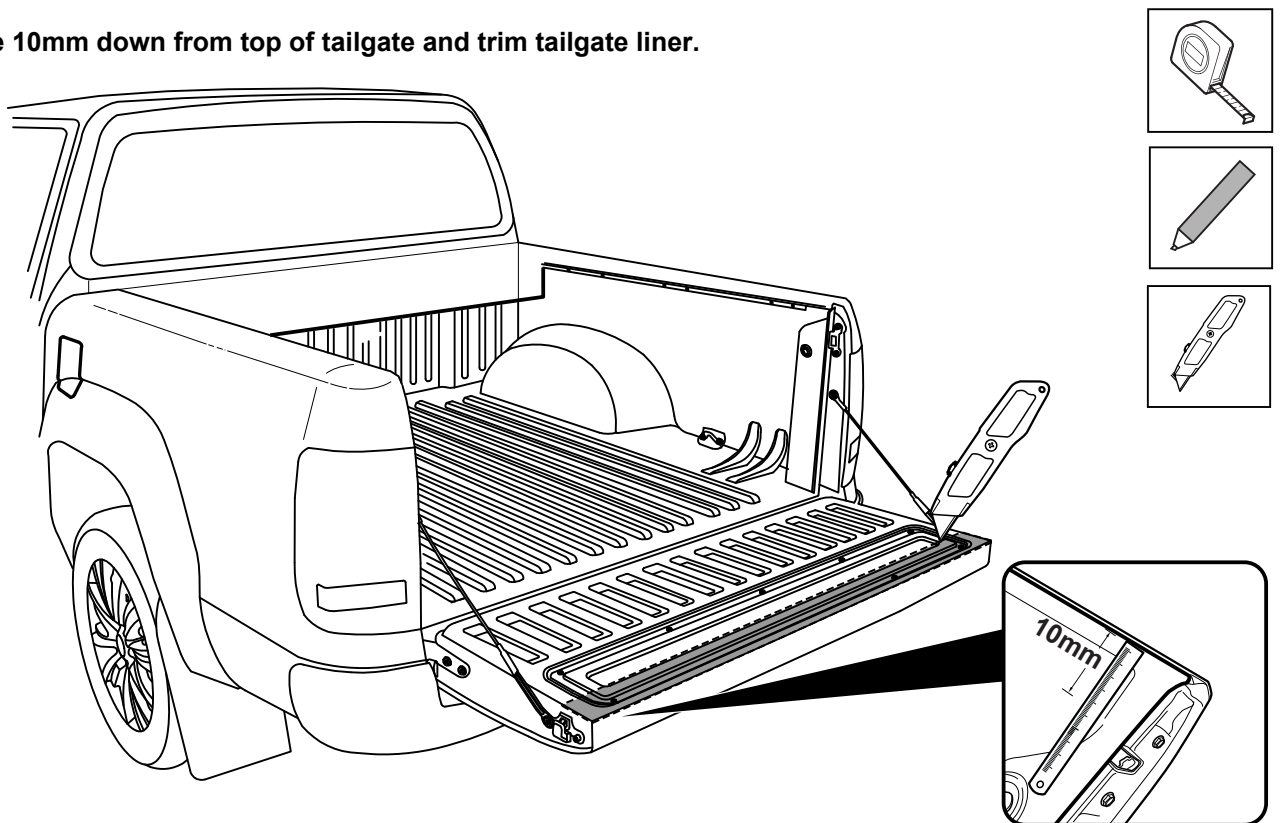

Measure 160mm down from top of Ute bed (head rail) and mark across to the other side.
Trim front of bed liner by 160mm from the top of the Ute bed as shown.

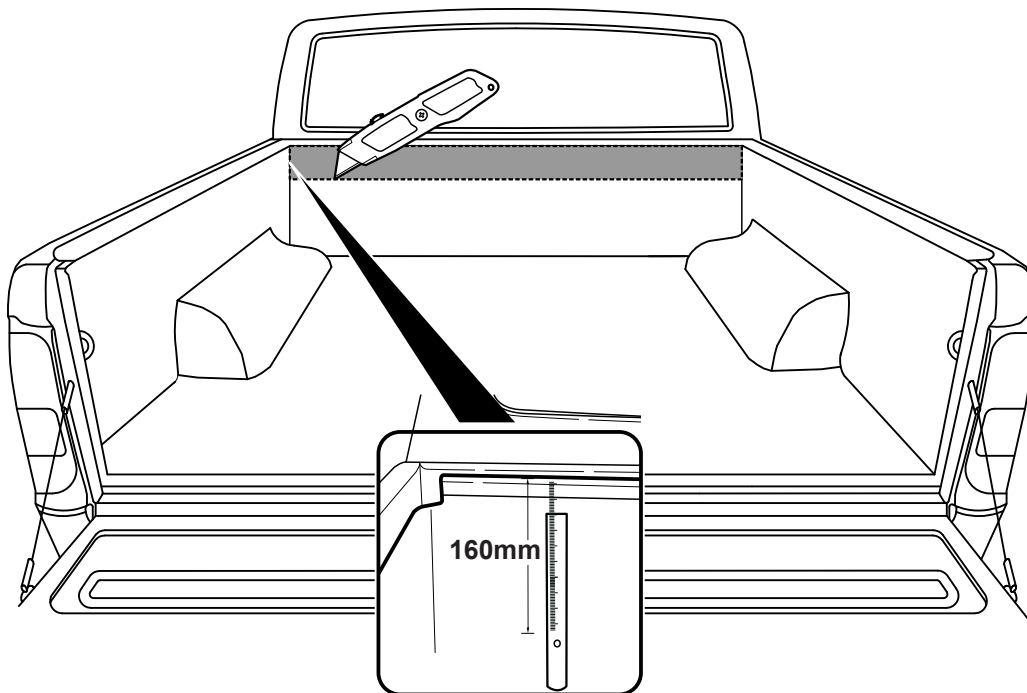

Cut a 20mm split for bed liner to flex.

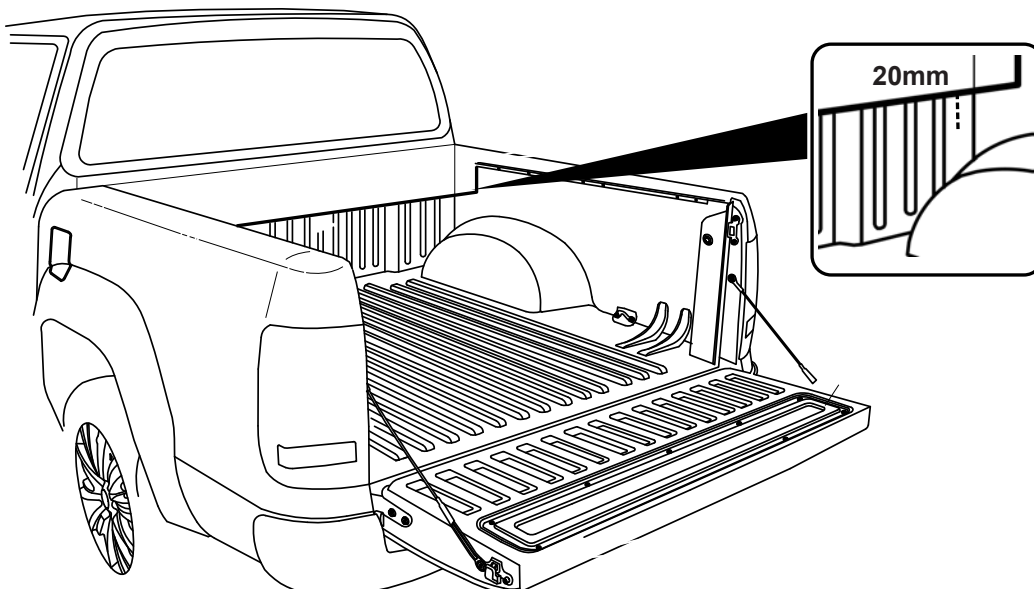

Measure down from top of assembly bar 200mm & 135 mm from inside wall of bed liner as shown. Repeat to the other side. Using a 50mm hole-saw drill the liner only as indicated.

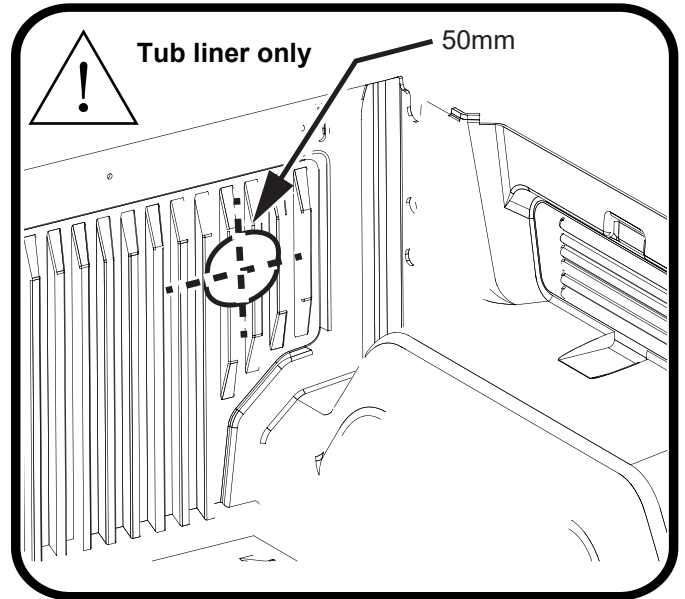
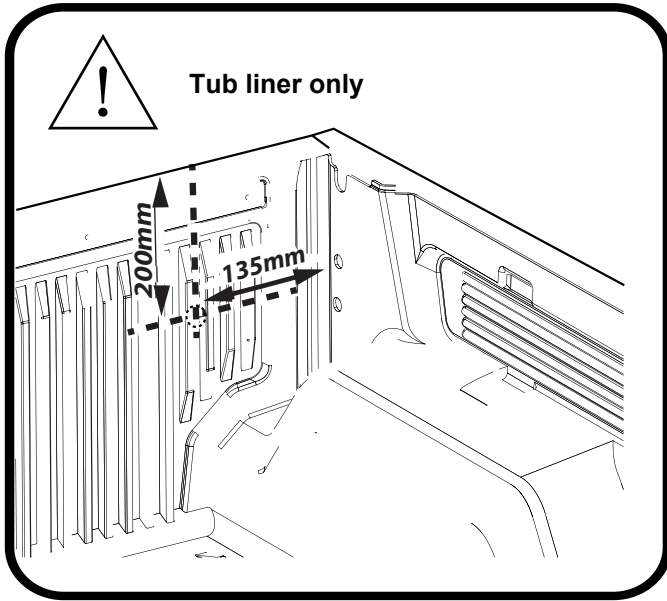
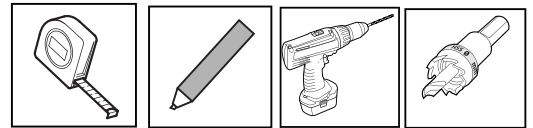

Measure down from top of headboard 200mm & 135mm from inside wall of bed as shown. (or 95mm if measuring from the side of the top rail) Repeat to the other side. Using a 30mm hole-saw drill through tub front panel, file away any sharp edges. Apply anti rust coating. Repeat to other side.

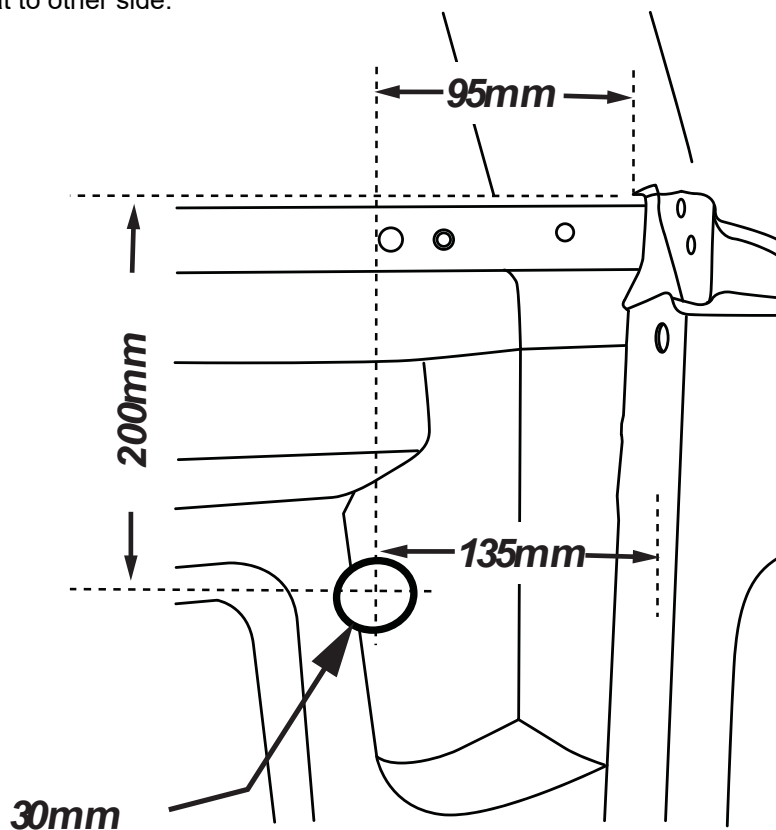
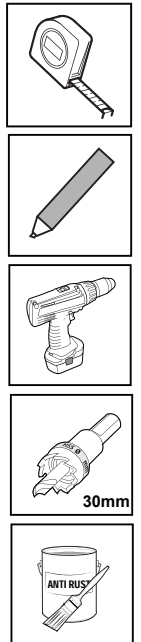

! ATTENTION: Do not exceed 30mm hole.

Seal any exposed gaps or holes on the front panel of the Ute bed with sealant.

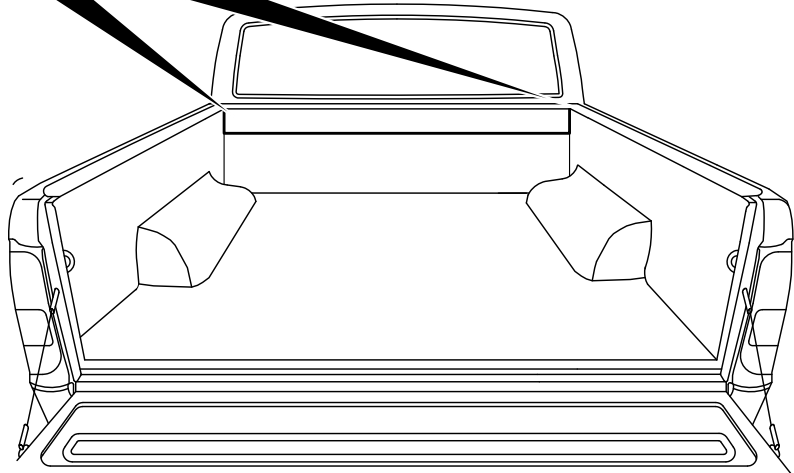
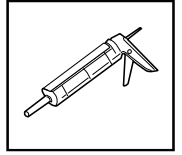
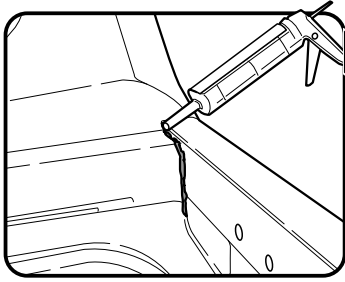

Carefully unpack the box.

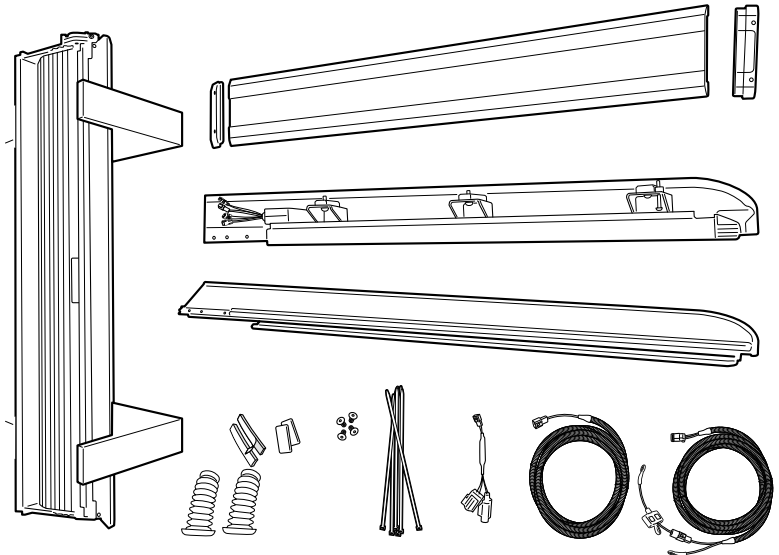
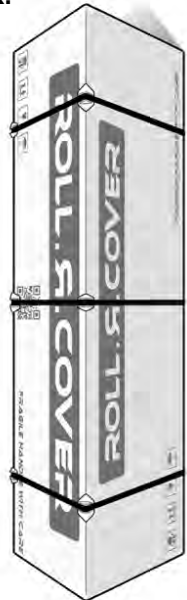

Install front drain pipes (55mm diameter end of hose) through pre-drilled holes on the front tub panel.



Note: With care push tube in. Taking care pull the tube back so it seals correctly against the front panel of the tub.

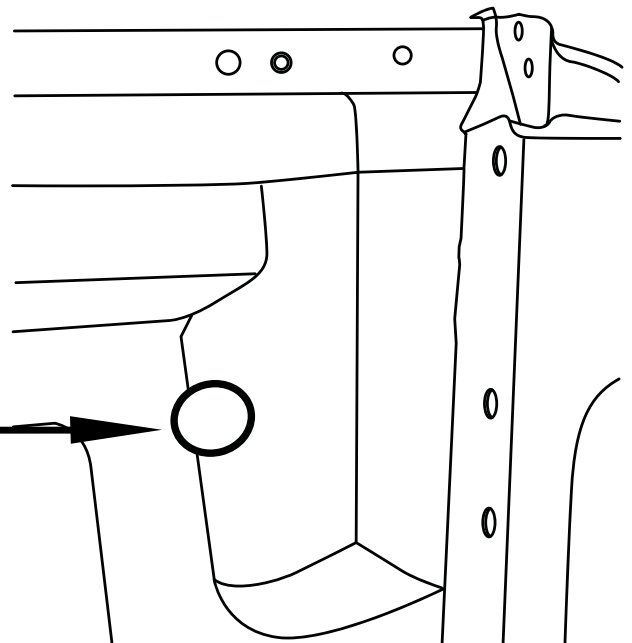
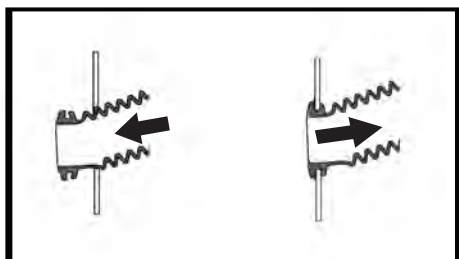

Disconnect fuse patch from battery loom S2.75.

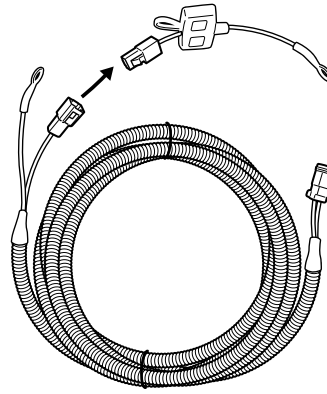

Wiring Harness steps

1 Feed Battery Loom S2.75 through the cavity

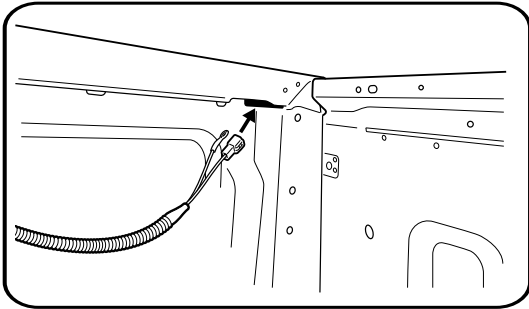

3

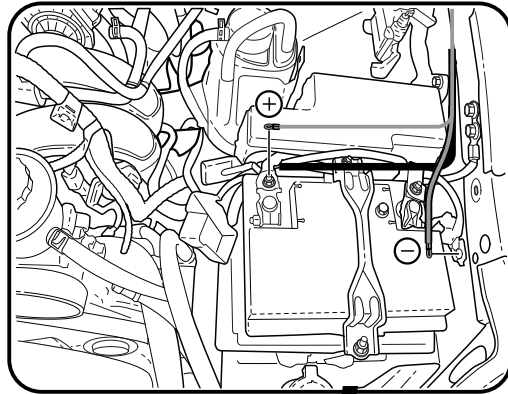

2

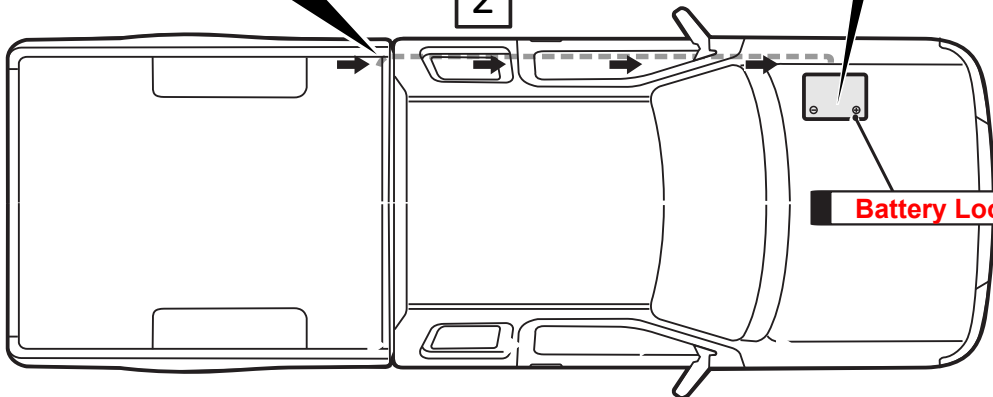

Run the wiring from the front corner cavity (leaving 200mm in the tub) to the battery over the chassis rail. Making sure to keep away from hot obstructions and cable tie every 400mm. Reconnect fuse patch to battery loom S2.75, now attach fuse patch to positive of battery and earth to the body of the Ute.

Feed CL-Short-Loom through the cavity.

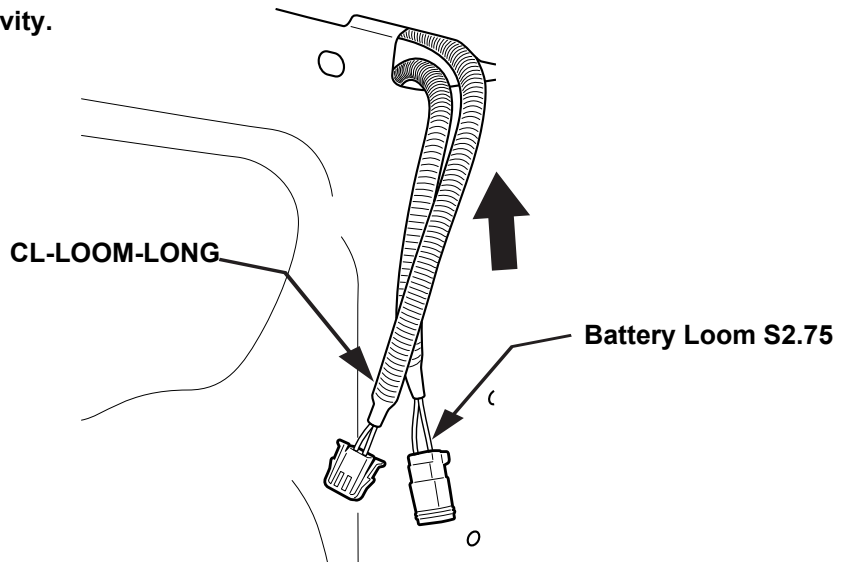

1) Route the CL - Loom-long harness along the LHS chassis rail to the grommet underneath the LHS front seat.

2) Secure the wiring every 400mm with the cable ties provided.

3) Make a slit in the grommet, pass the actuator wiring harness through the grommet (1) and using silicon, reseal the slit.

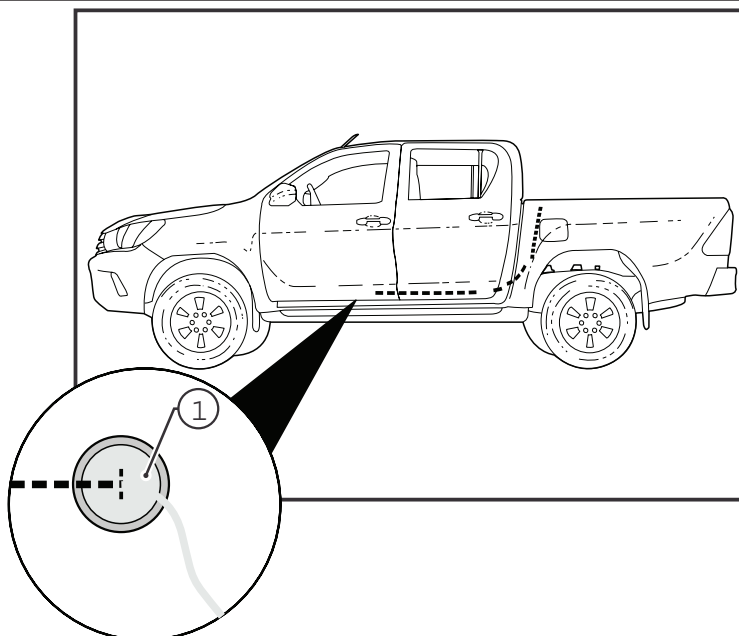

At the front passenger side foot well area:

- Remove front passenger scuff plate (1)
- Remove the kick panel trim nut (2)
- Remove the kick panel (3)

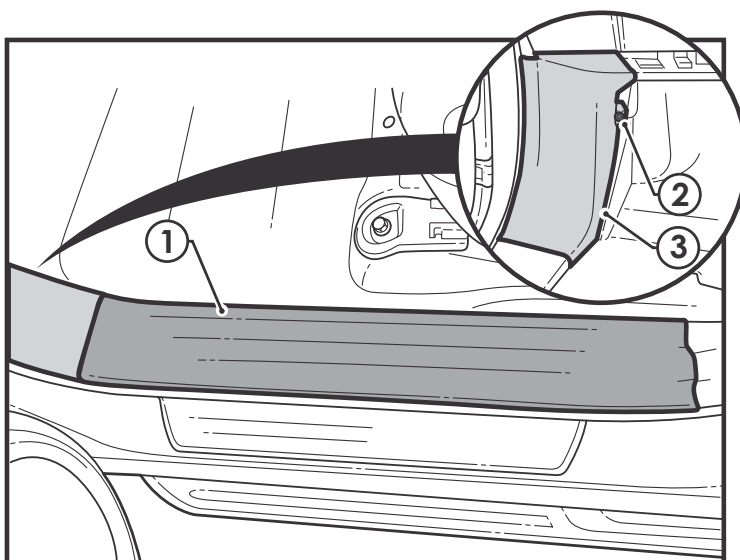

Continue routing CL - Loom-long wiring harness (1) through the grommet, along the door sill up to the LHS kick panel, following the existing vehicle harness.

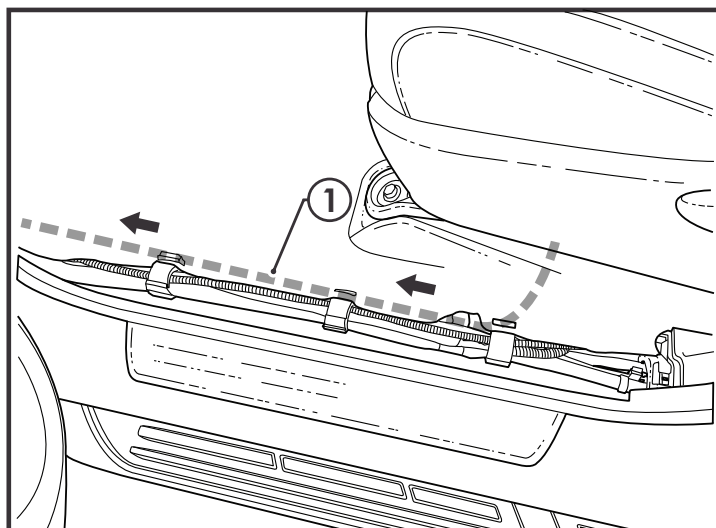

Locate and disconnect the 20-way hybrid junction connector (1) in the passenger side kick panel area.

Identify the two Lock/Unlock terminal wires as shown:

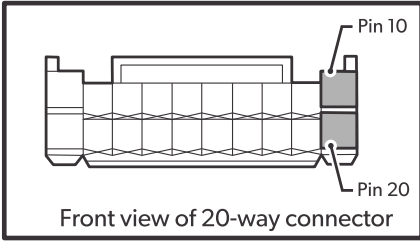

Connector Pin 10: Lock / Black Wire
Connector Pin 20: Unlock / White Wire

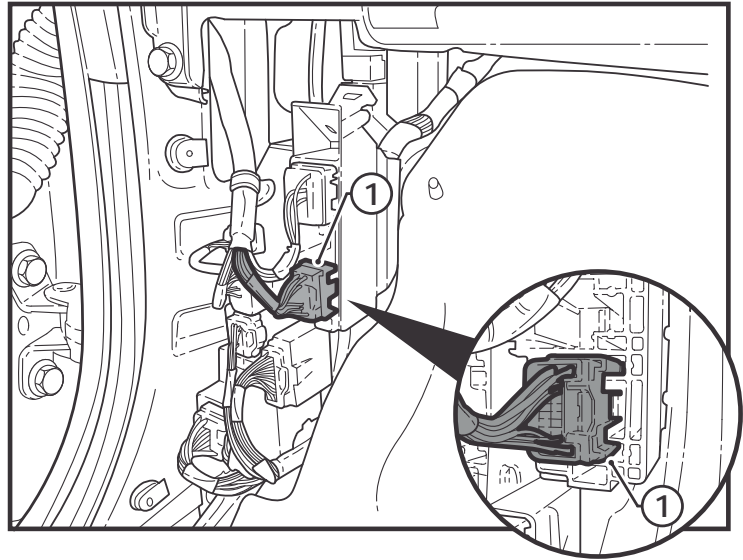

Using a precision screw driver, unclip the connector secondary lock (1). Carefully remove the two lock/unlock wires from the rear of the connector using a precision screw driver.

House the Blue & Red lamp vehicle harness terminals (2) into the rear of the connector cavities in the position shown:
Red Wire Upper Cavity (3)
Blue Wire Lower Cavity (4).

Push the 20-way connector secondary lock (1) into place to retain terminals.

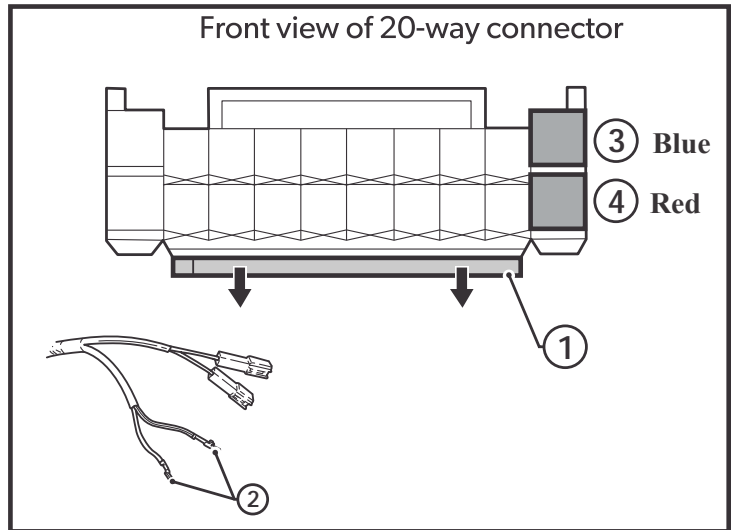

House the lock/unlock wiring terminals, previously removed from the vehicle harness (1) into the supplied 2-way male connector (2) as shown, now Connect the wiring harness to the vehicle patch harness 2-way connector (3).

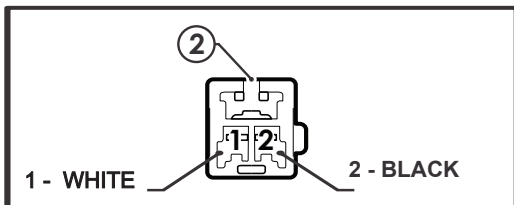

Rear view of 2-way connector

Check the wiring harness and vehicle patch harness are securely attached to the main vehicle harnesses.

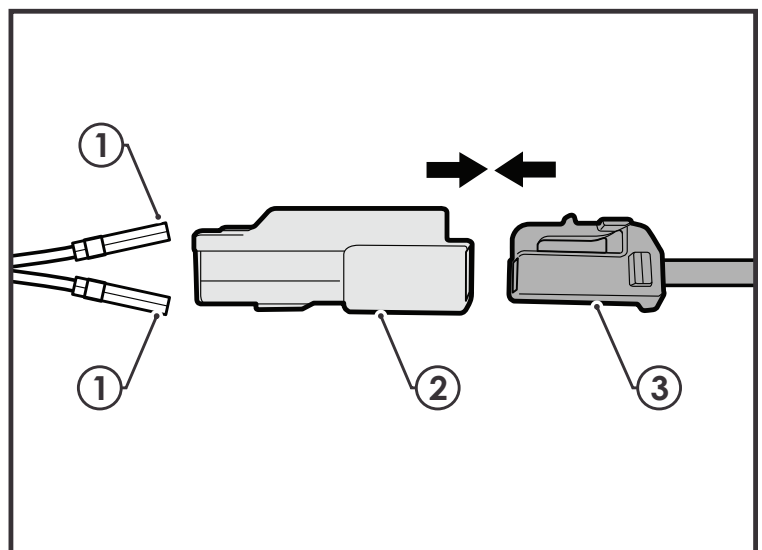

Connect X-PATCH loom to CL-LOOM-LONG

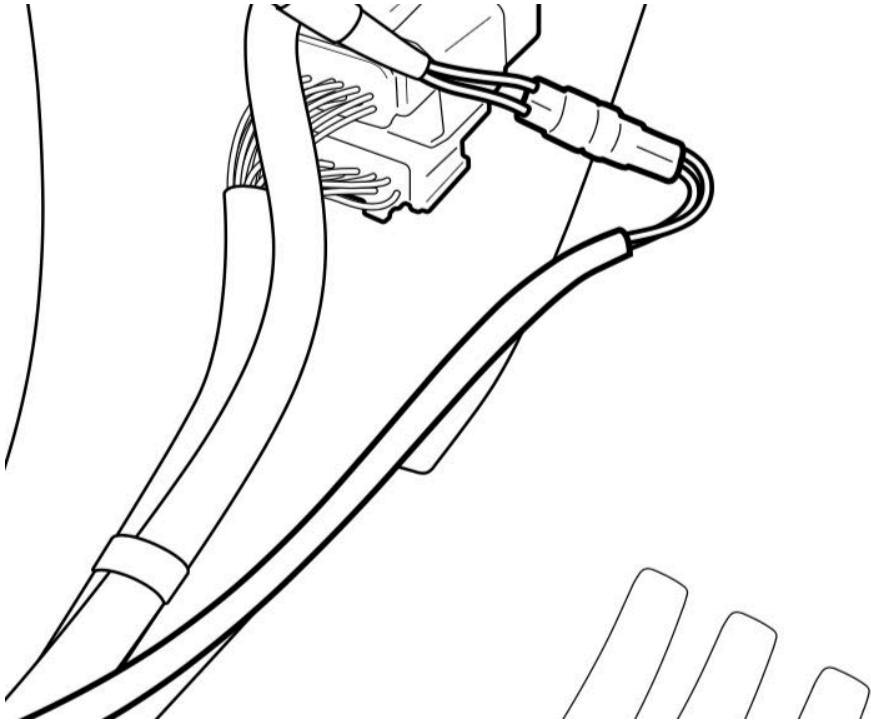

keep the cannister in the foam blocks from the packaging for assembly.

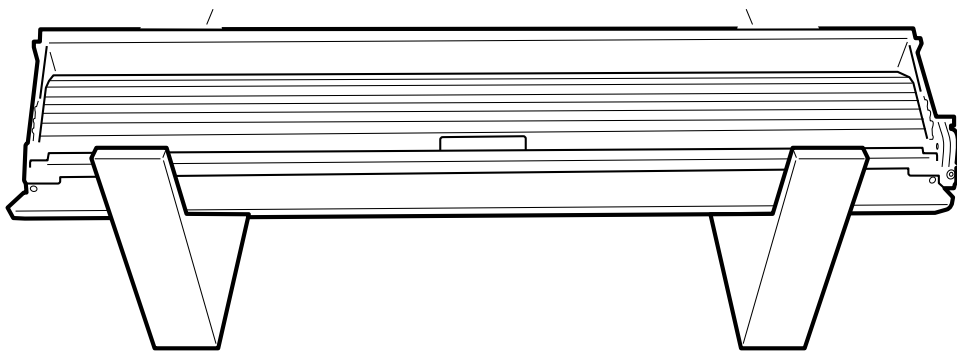

With assistance turn the canister on its back on the foam blocks.

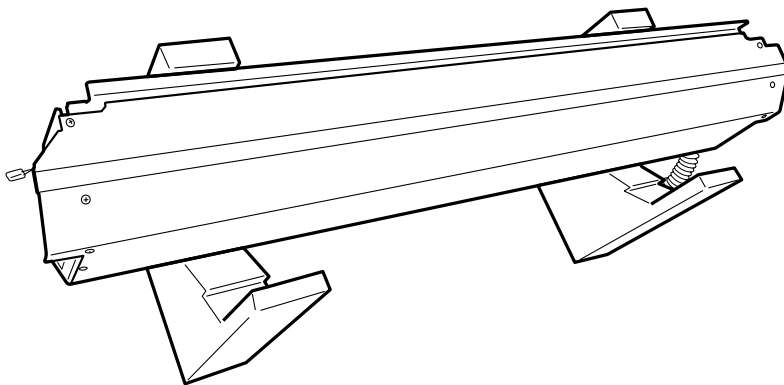

Disengage motor from the axle by unfastening the 3 Screw as indicated. Retain all parts.

Remove and retain the 3 screw from the canister as indicated.

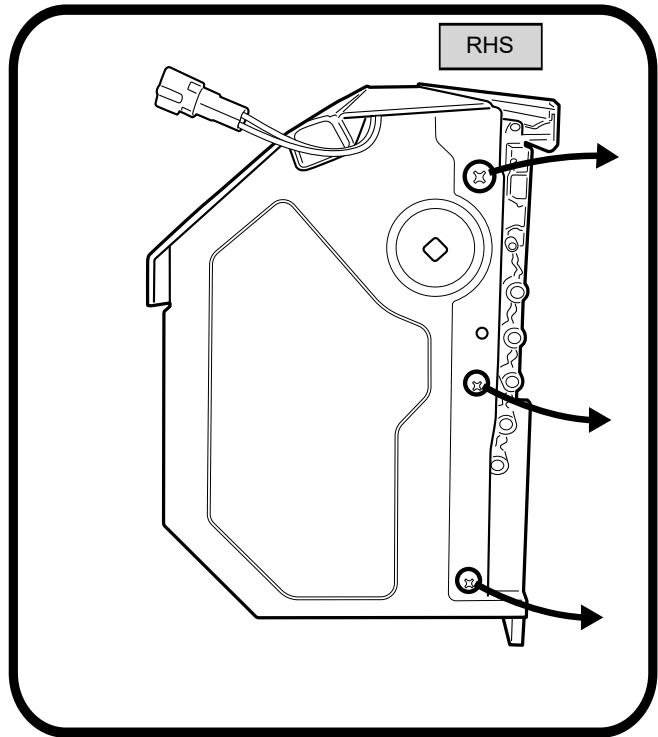
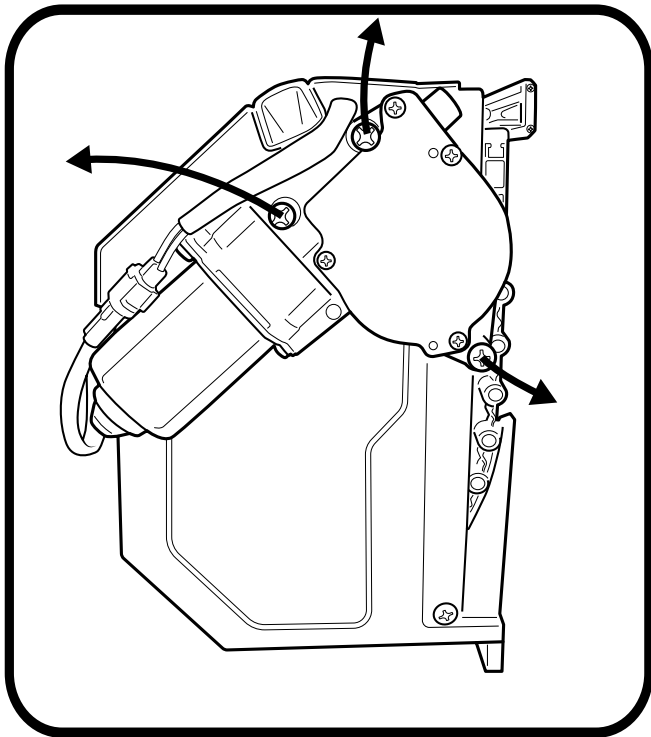
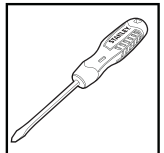

Now on the other side, remove and retain the 4 screws from the canister as indicated.

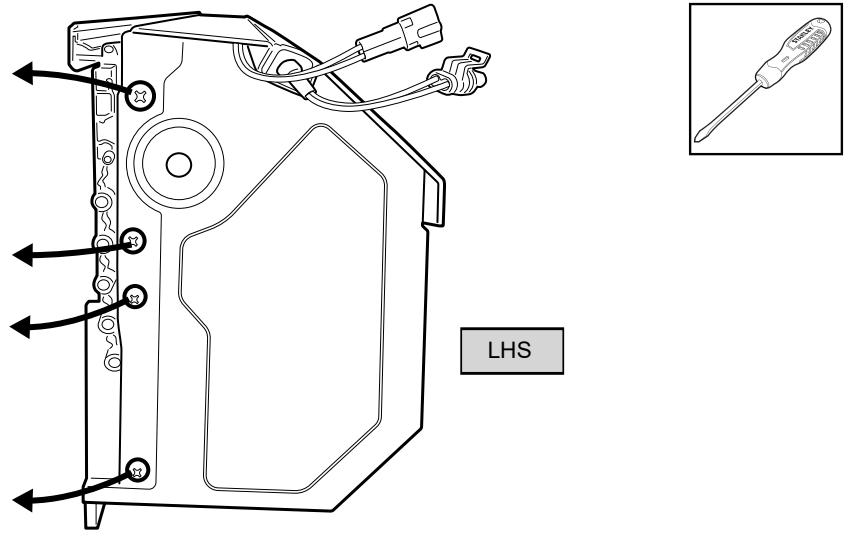

Align side rail to side of canister, guide the track to go in between the curtain end rubber stop.

NOTE: LHS side rail to be assembled first.

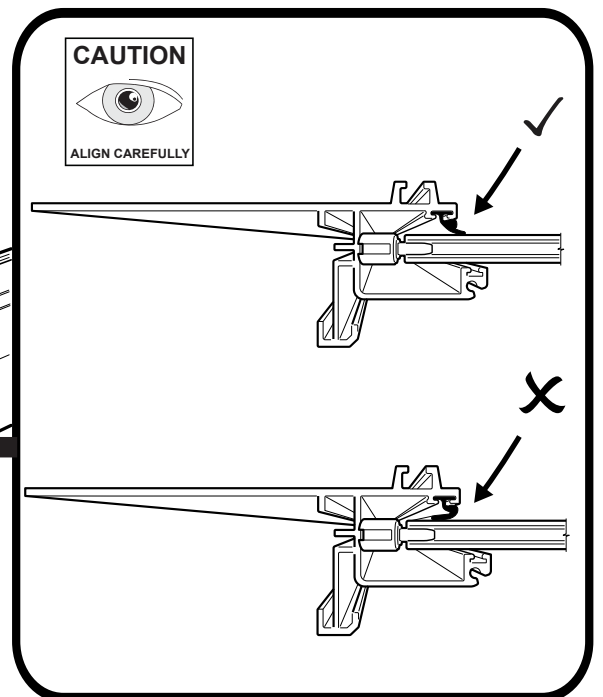
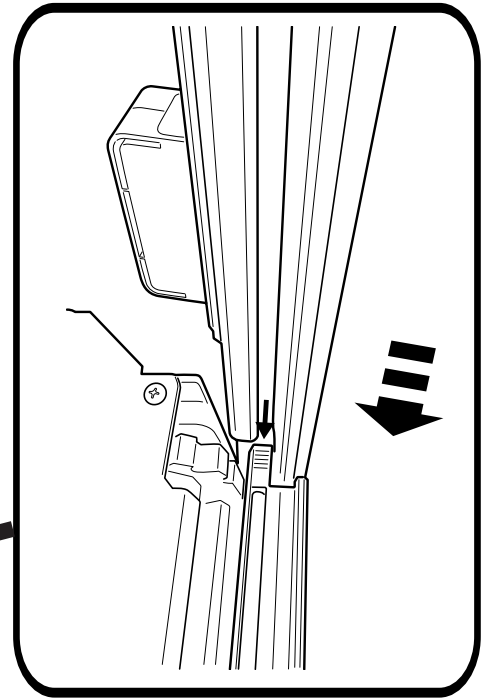
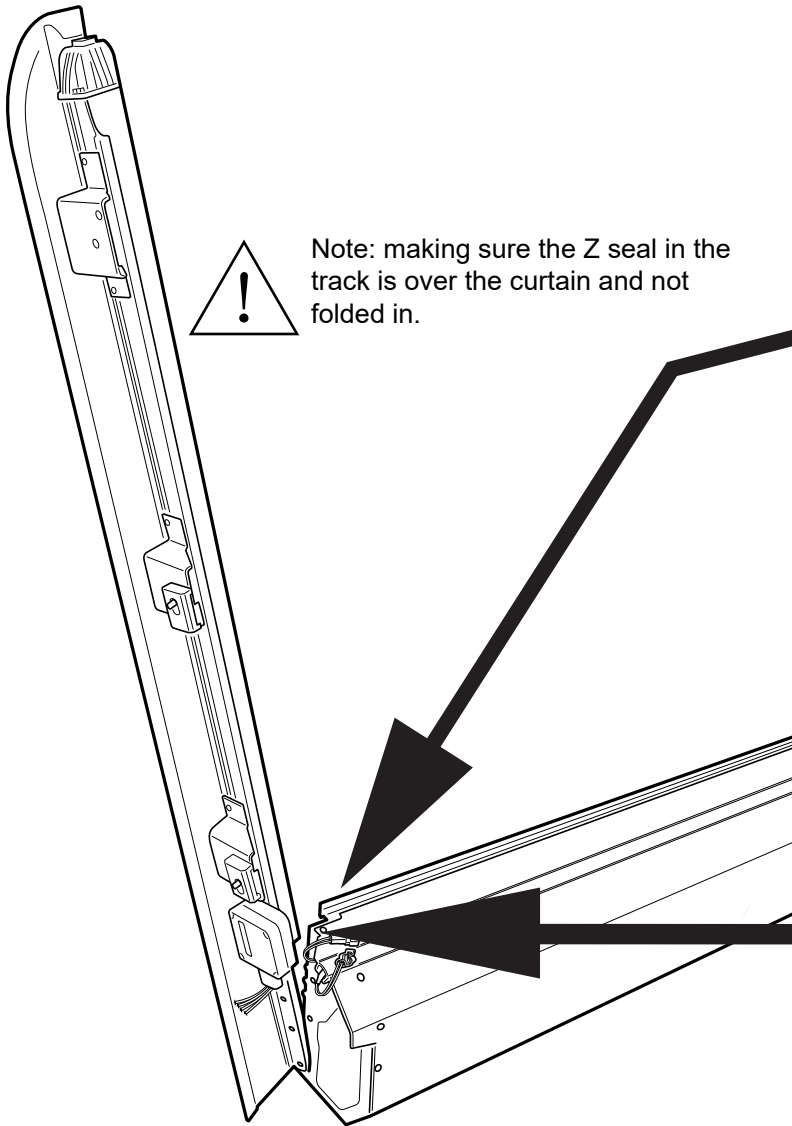

Fasten the side rail using the retained screws.

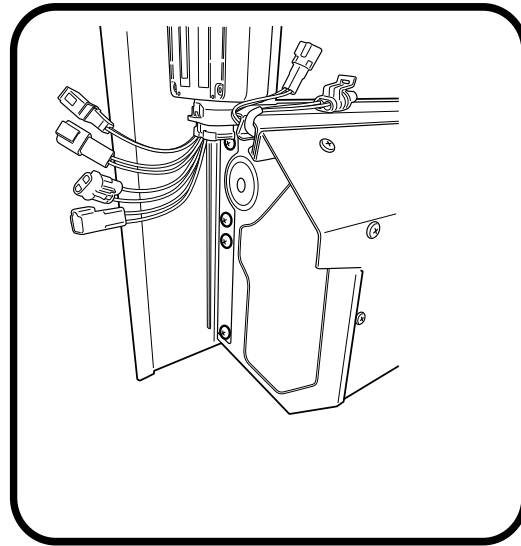
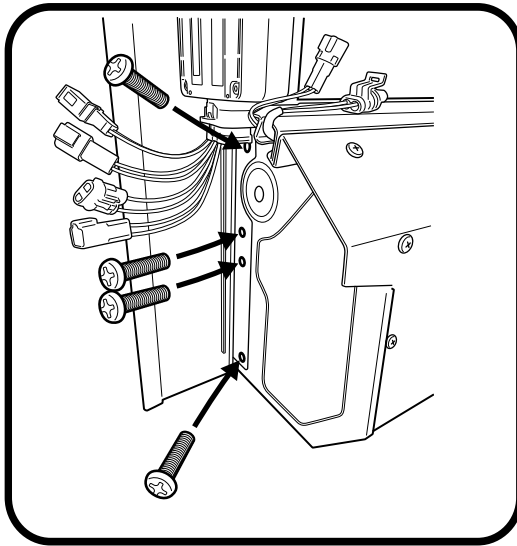
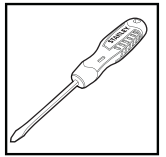

Connect motor connector to receiver

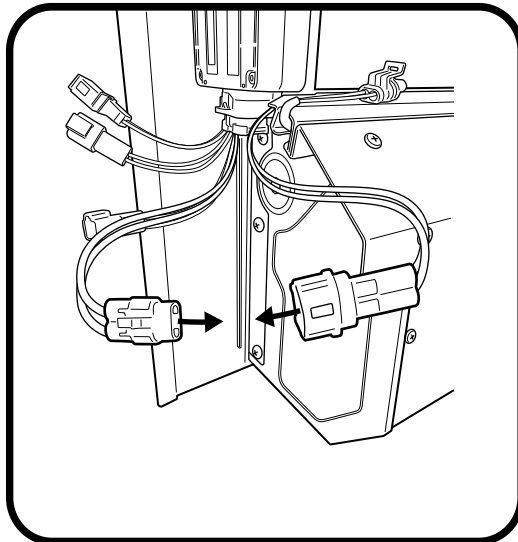

Connect LED Loom to receiver

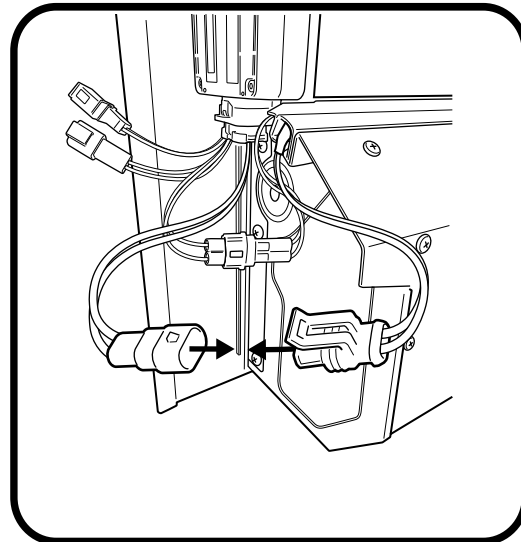

Align side rail to side of canister, guide the track to go in between the curtain end robber stop.

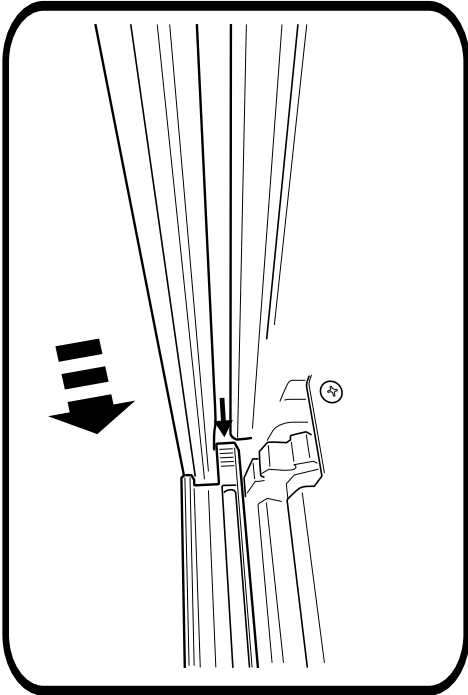

Note: making sure the Z seal in the track is over the curtain and not folded in.

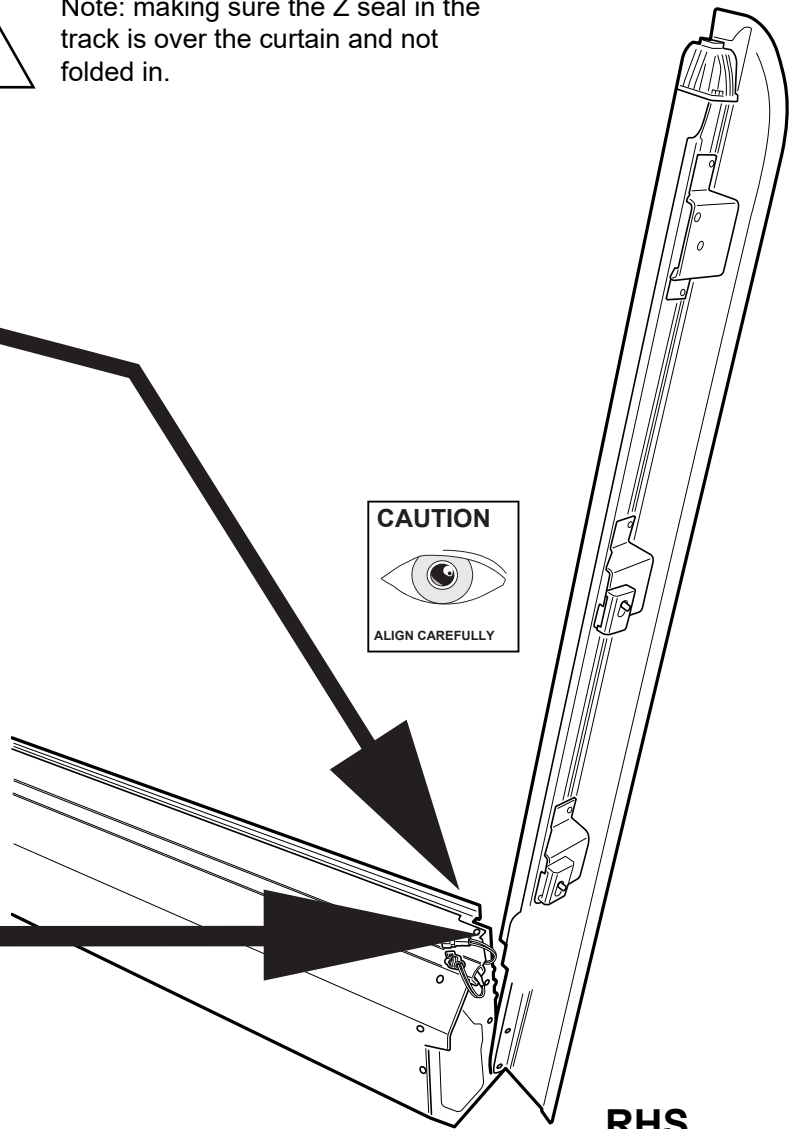
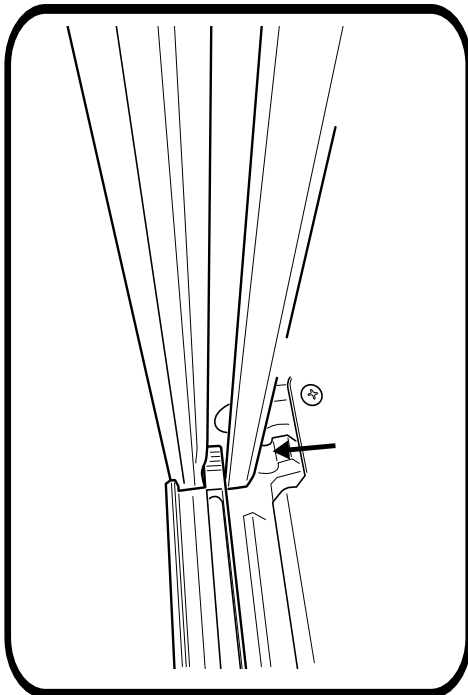

RHS

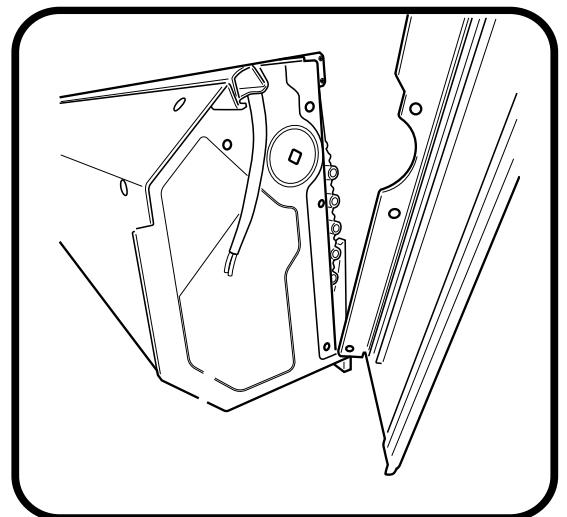

Fasten the side rail using the retained screws only to the locations indicated.

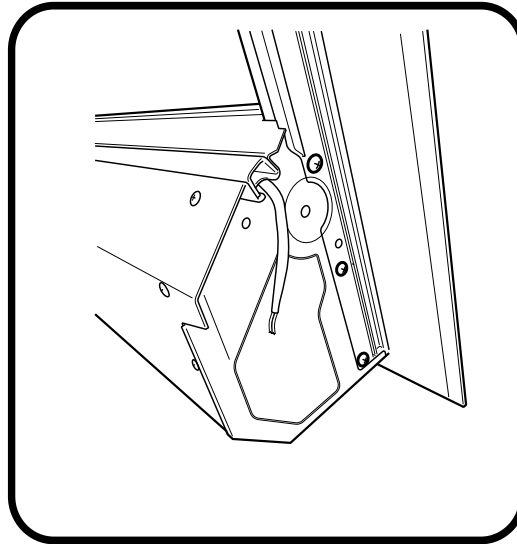
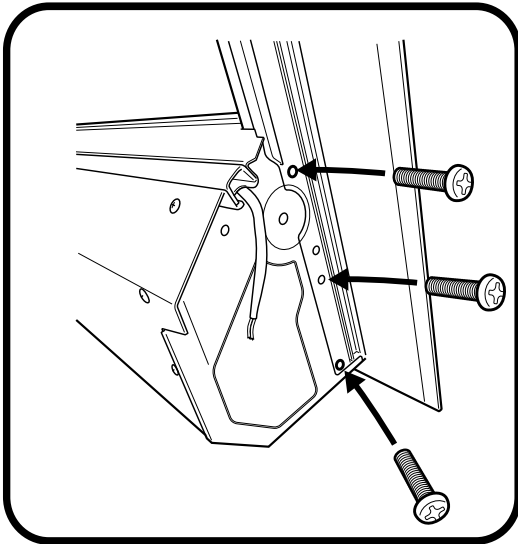

Align & insert motor to the axle.

Pull Curtain out if required to align motor with thread and loosely fasten with retained screw.

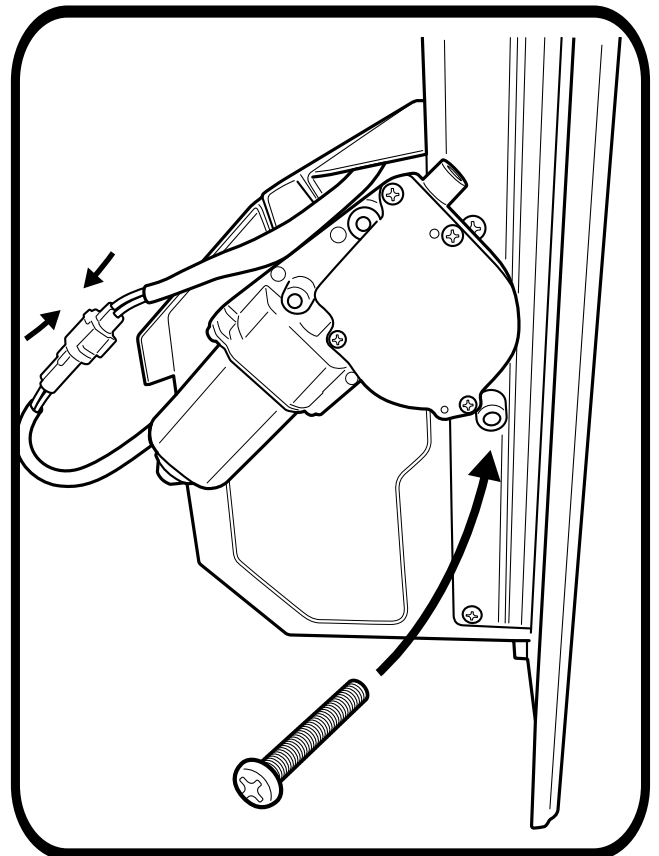
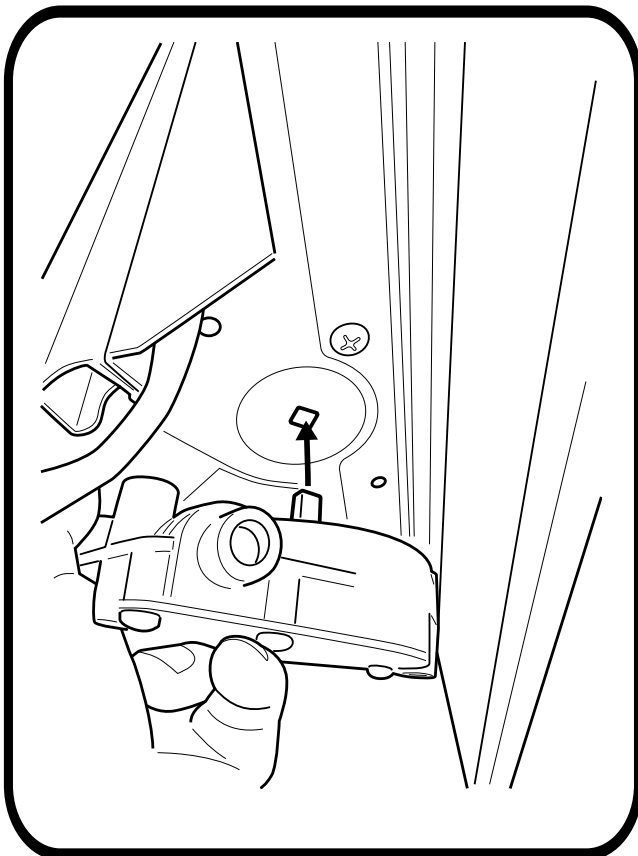
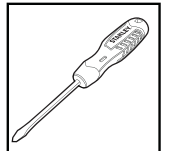

Loosely fasten with retained screws.

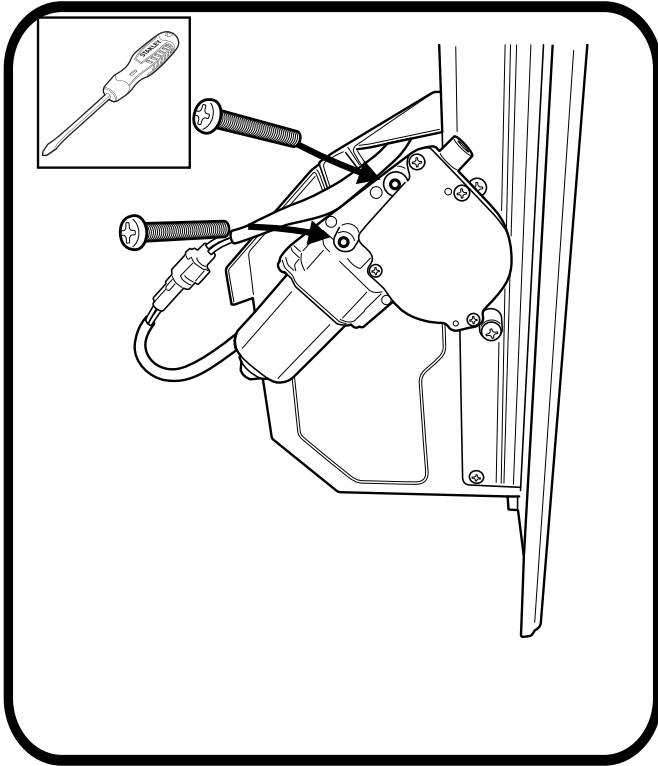

Fasten all 3 screws tight.

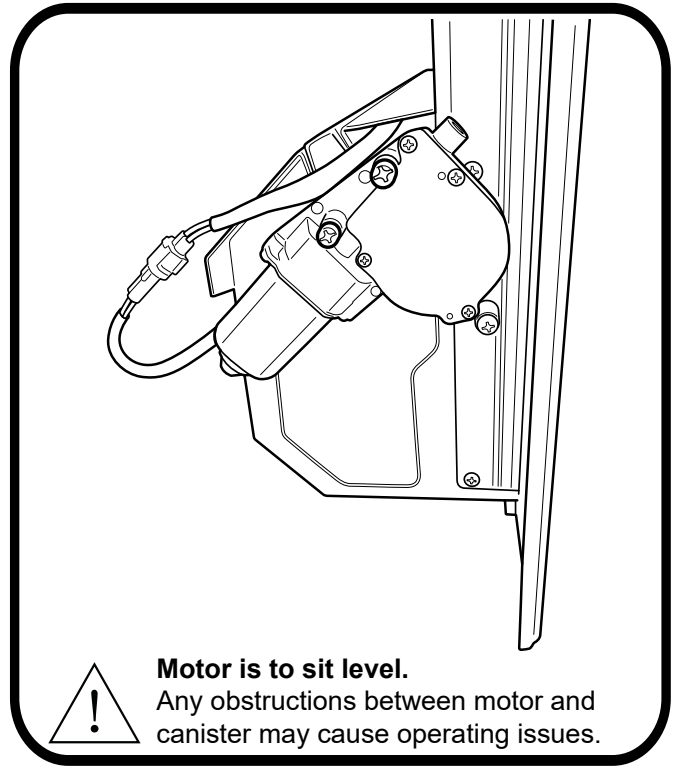

Apply D-sponge foam tape to side rail as indicated. NOTE: Join foam firmly to the pre-fitted foam of the canister. Carefully trim excess off & discard as indicated. Repeat on the other side.

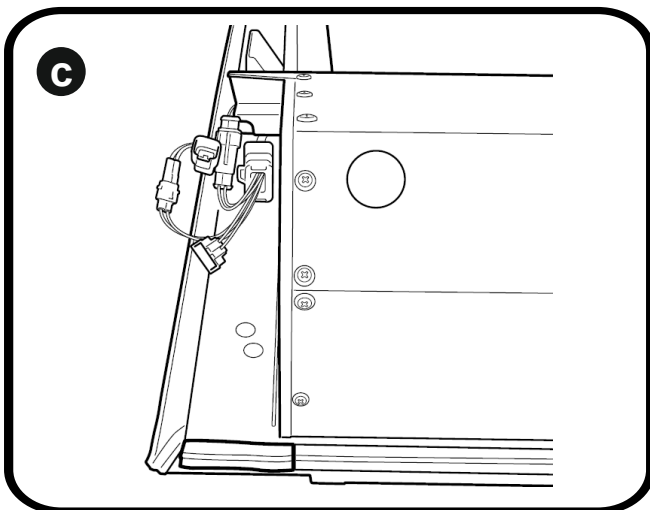
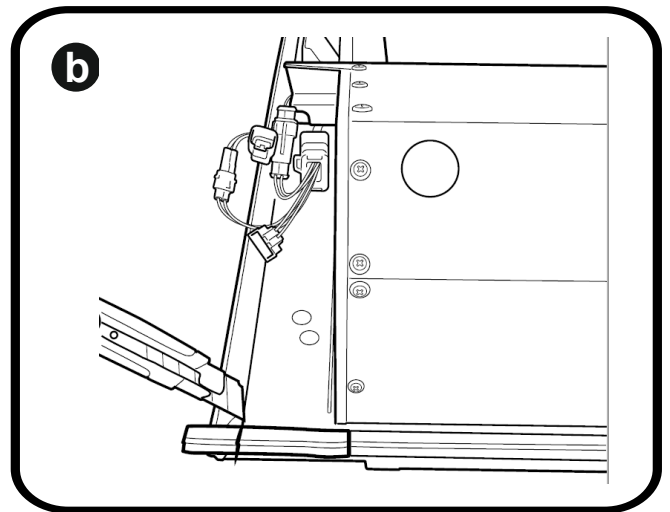
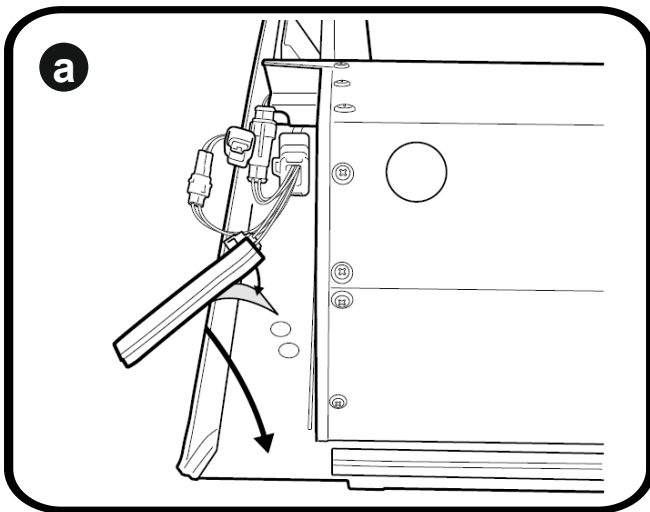

Carefully bring down the assembled unit .
Then unfasten the clamps from the left & right side rails - retain clamps & hardware.

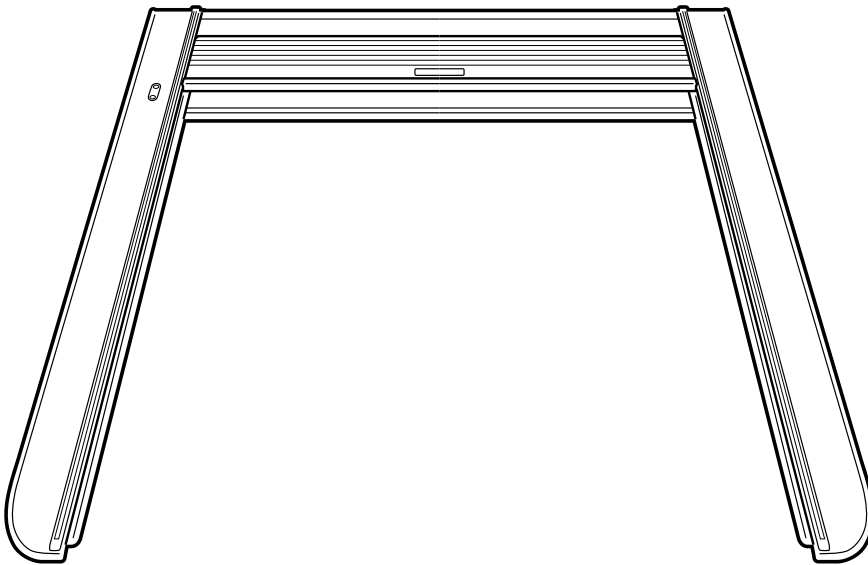
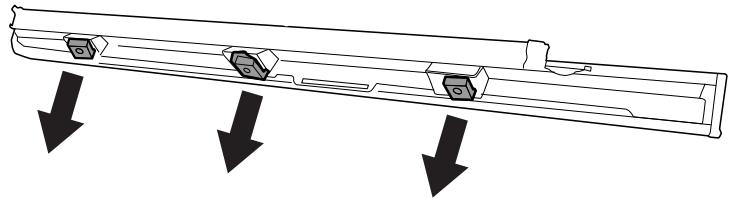

Insert side end caps to the top cover.

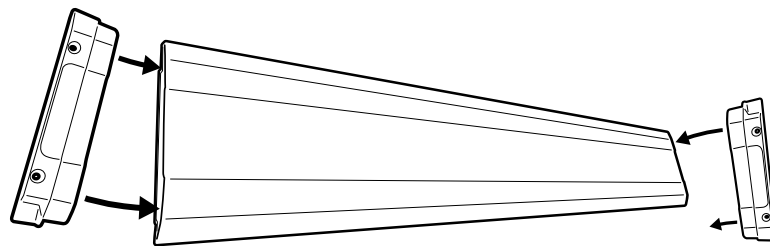

Place & Align top cover over the
canister and side rails.

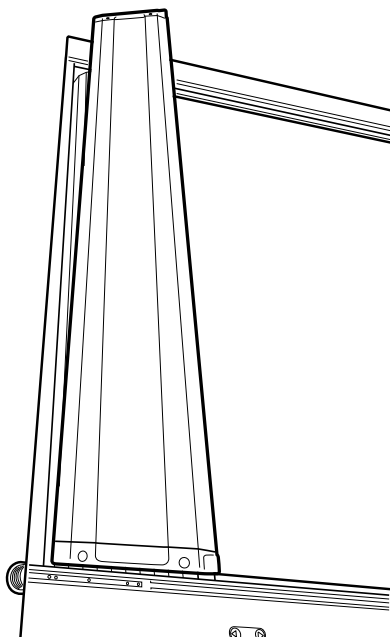

Using countersunk screws provided, line up end cap
holes to the threads on the side rail.
Fasten to 3nm torque. Repeat to the other side.

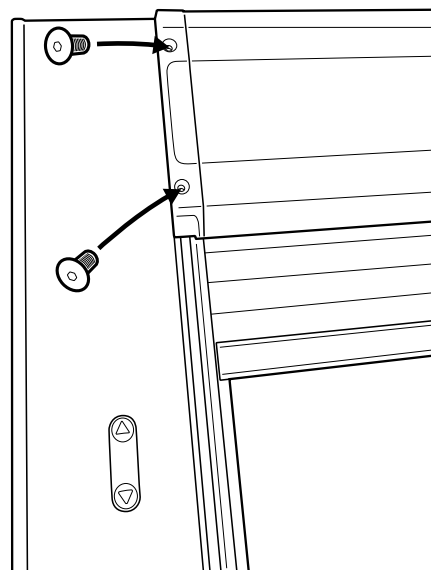

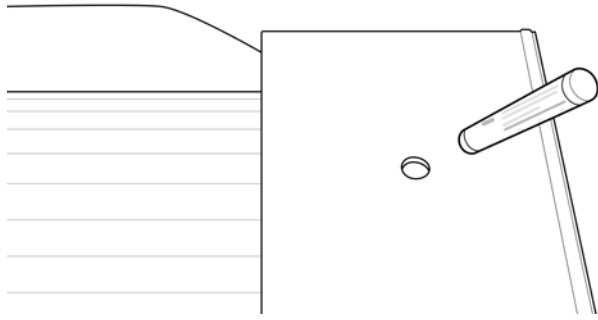

Apply 3M primer provided around all side rail holes.

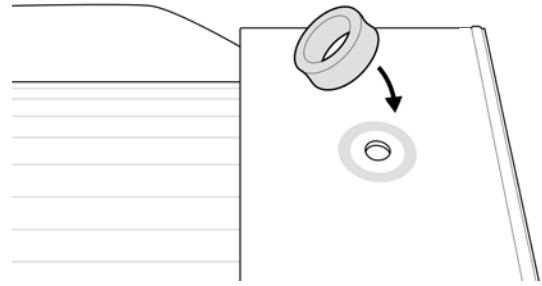

Peel away backing from foam sealant and stick to side rail. Repeat on all 4 holes.

Place spacers in-between all foam seal over the holes of the side rails.

NOTE: Location A is the 18mm high spacer.
Location B is the 16mm high spacer.

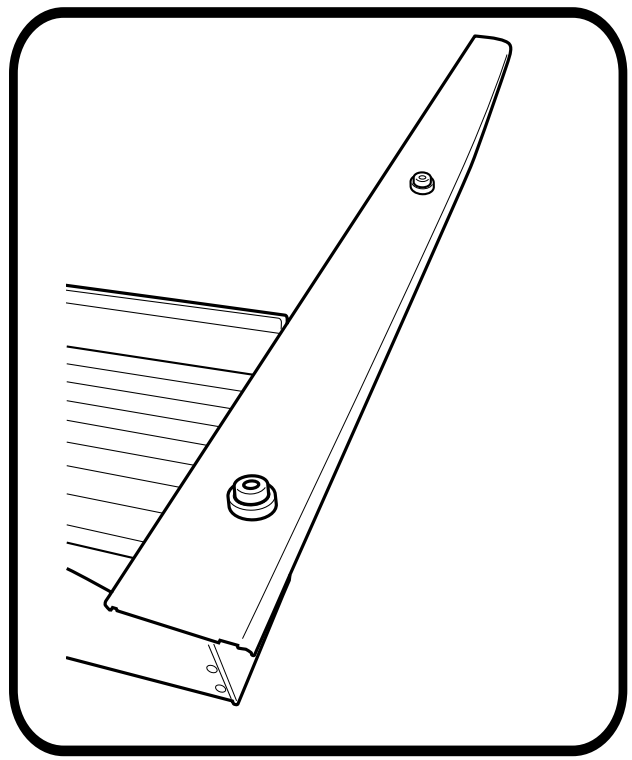
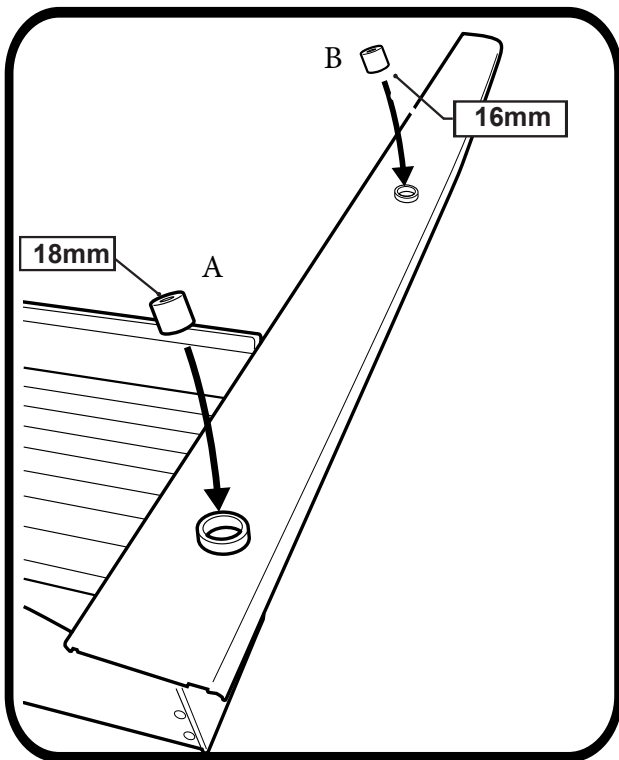

Remove all factory brackets from sports bars. Repeat on all four legs.

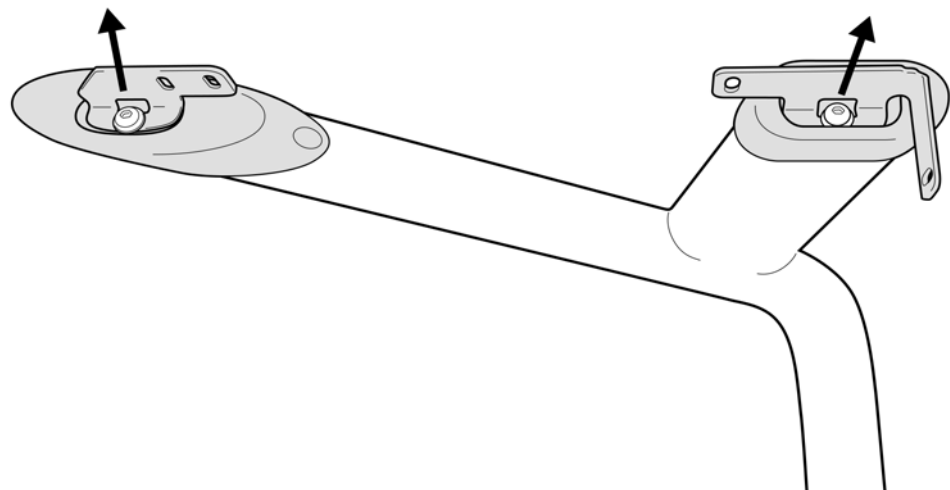

Using gaskets supplied, remove adhesive backing & attach foam gaskets to their correct upper foot cups.

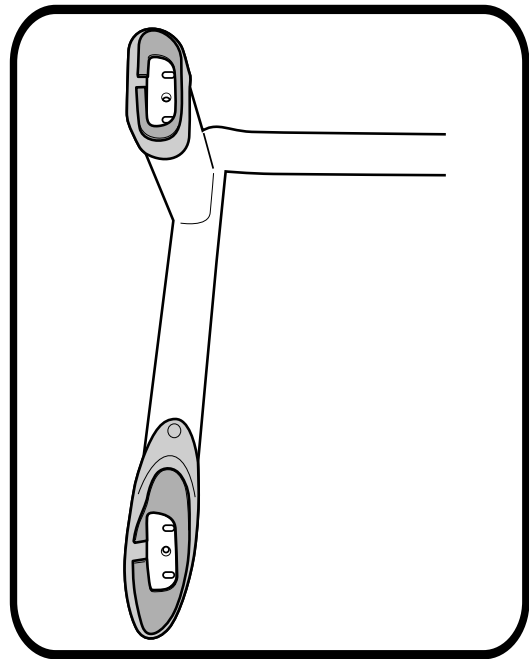
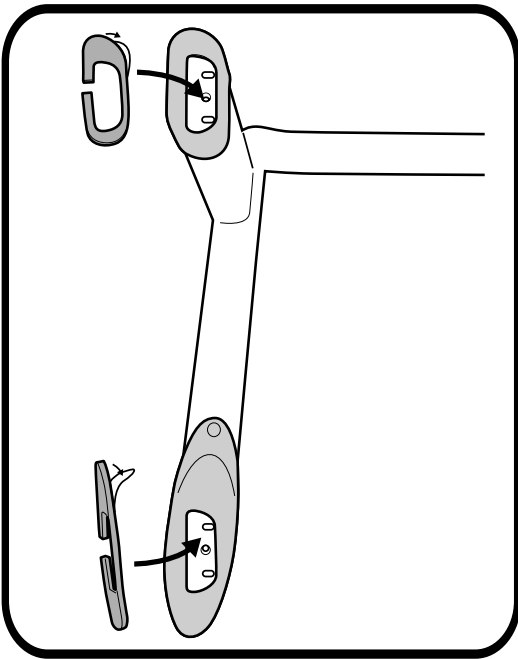

Place Sportsbar on Roll R cover

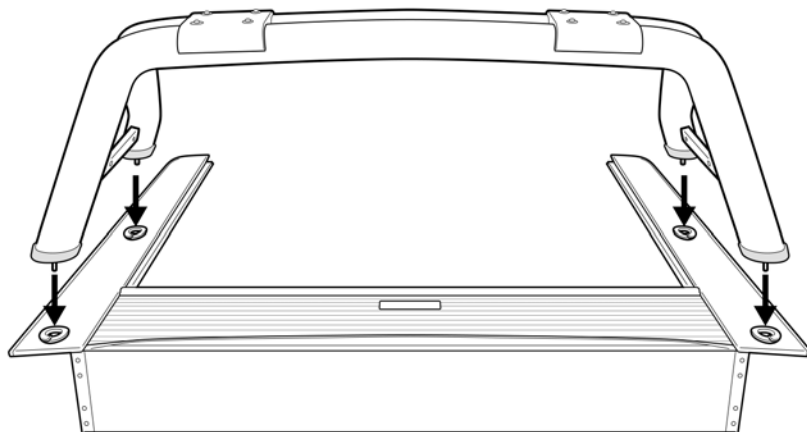

Feed through your bolt, spring washer through the hole, align with sports bar thread. Repeat on all four legs.

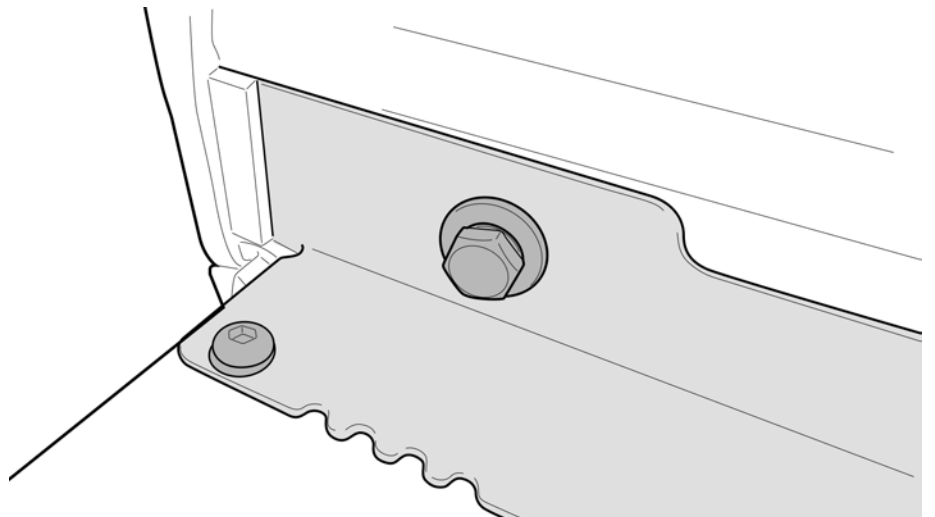
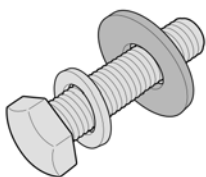

Place the Roll-R-Cover unit on to Ute bed.

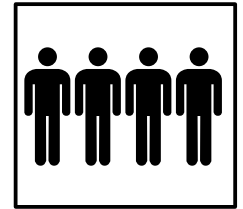
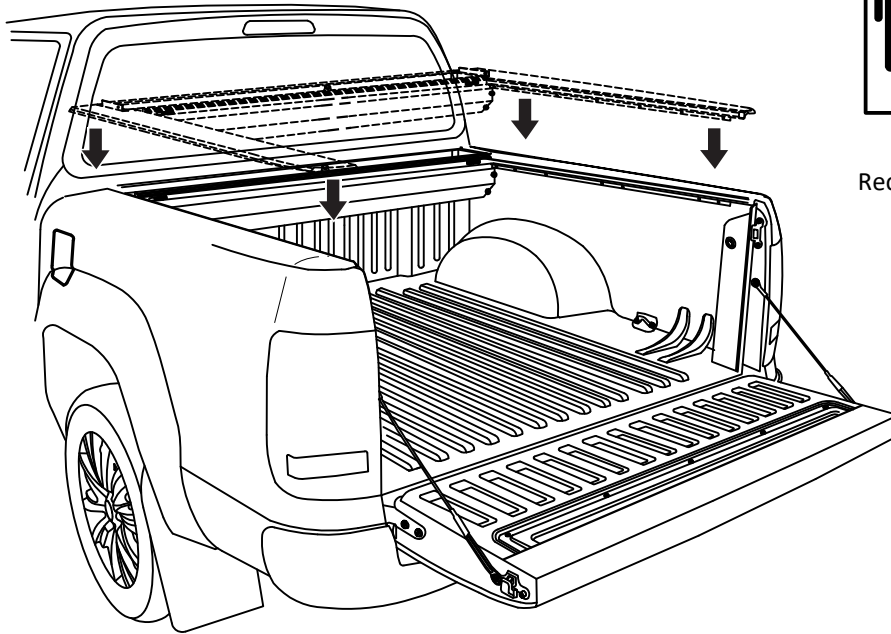

4 People
Recommended for lift

With care, pull out any side rubber that has folded under the side rail.

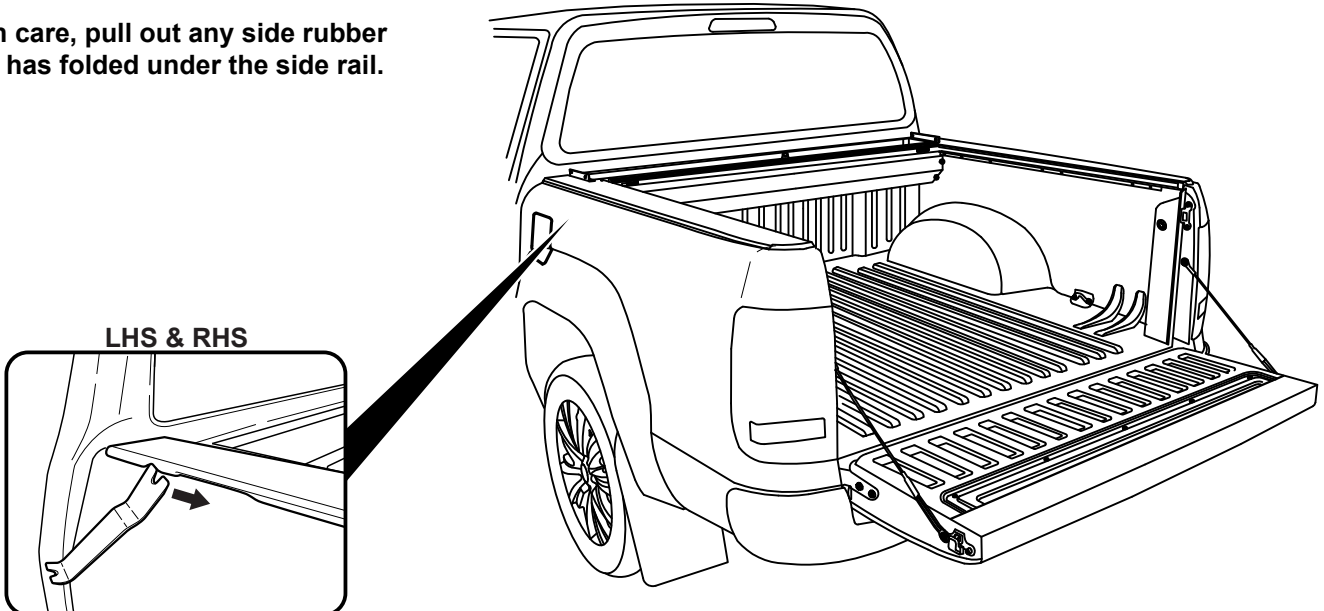

With the tailgate up (Closed position),
Pull left & right hand side rails
towards the tailgate, stopping short by
5mm between tailgate and side-rail
end-cap.

5mm

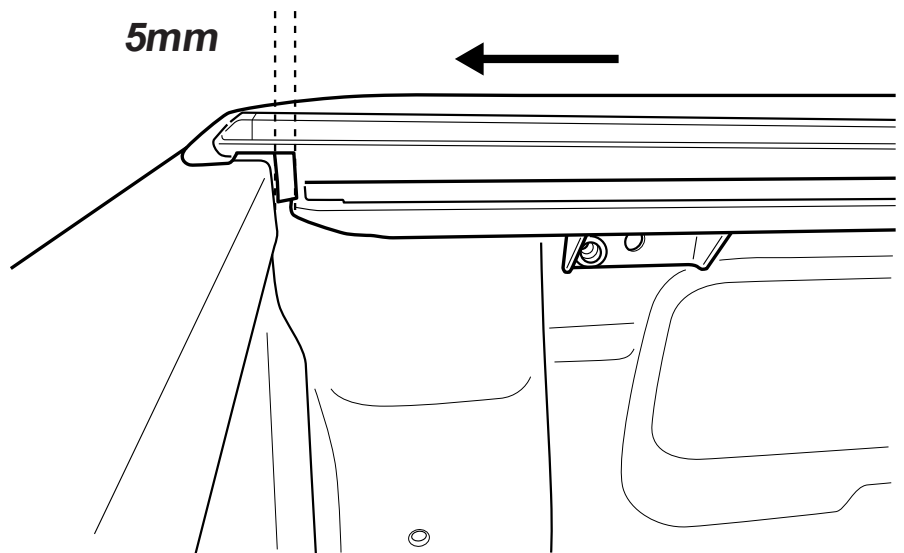

Foam compressed to
5mm when tailgate is
closed.

Gap between tailgate and side-rail end cap to be 5mm.

Foam seal

Side rail end cap

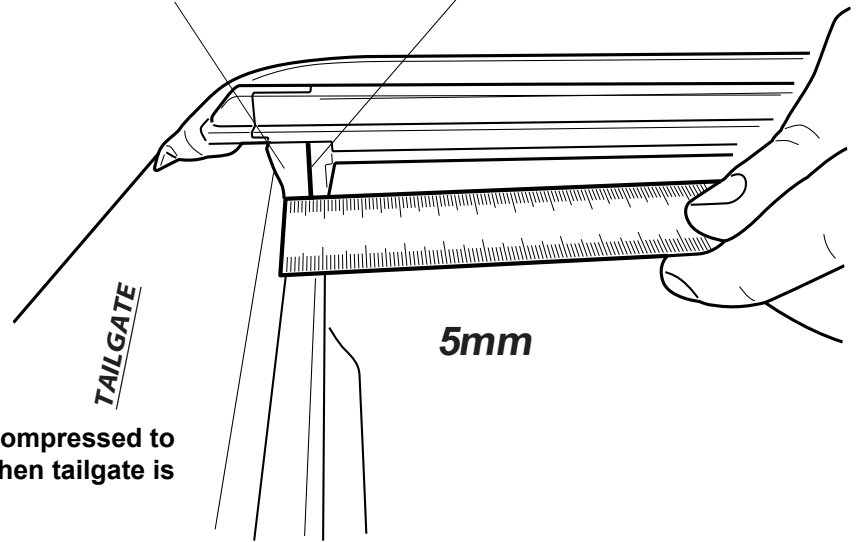

Foam compressed to 5mm when tailgate is closed.

Position clamp behind the inner top lip of the bed rail and the side rail mounting brackets. Repeat to all 6 positions.

Ensure the M8 nyloc nut is in indicated slot of the clamp

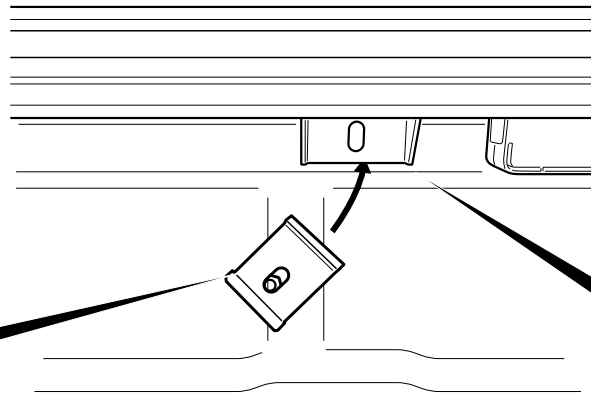
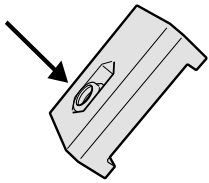

Fasten clamp loosely into position using retained M8 washer and bolt.

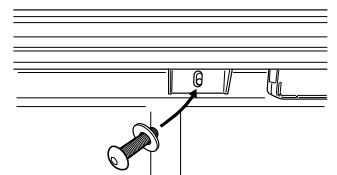

Apply pressure then tighten clamps in the order indicated.

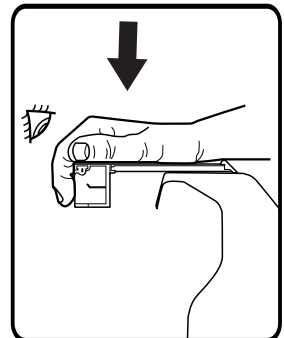
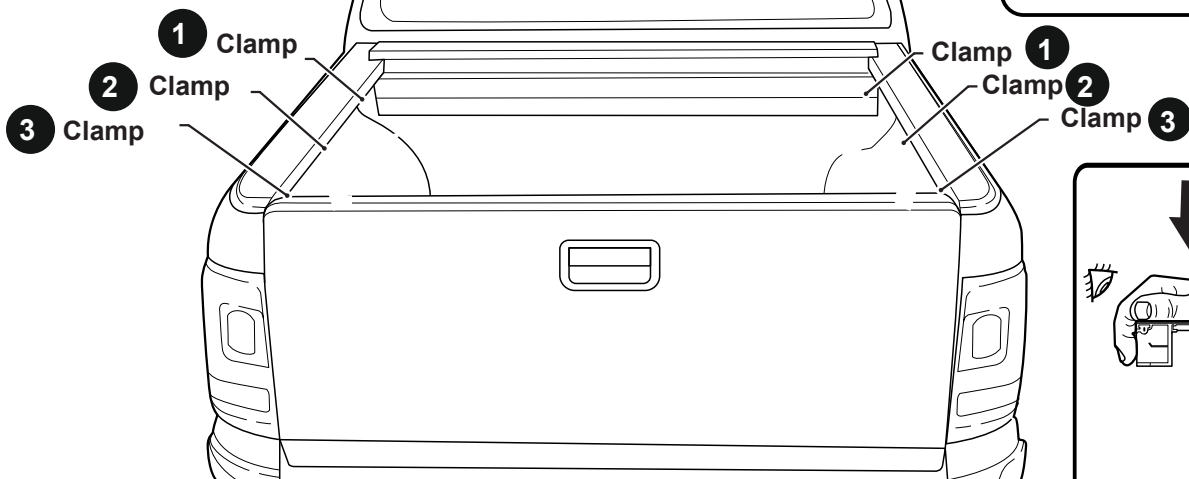
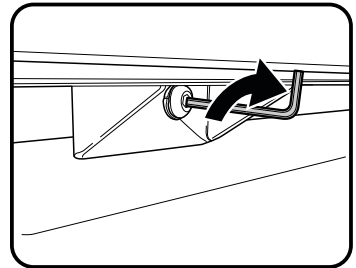

Apply flat plate behind adjusting bolt hole to the ute bed panel or to the liner if the Ute is equipped with a tub liner.

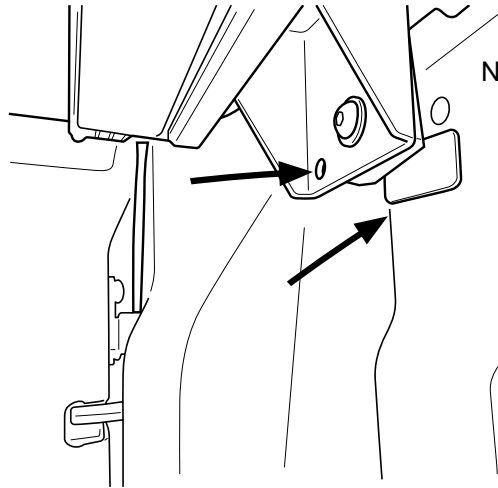

Note: Rear Clamp bracket.



Note: Clean surface before applying flat plate.

Feed M8 bolt through clamp bracket's pre-installed nutsurt as indicated (keeping M8 nut on the bolt thread).

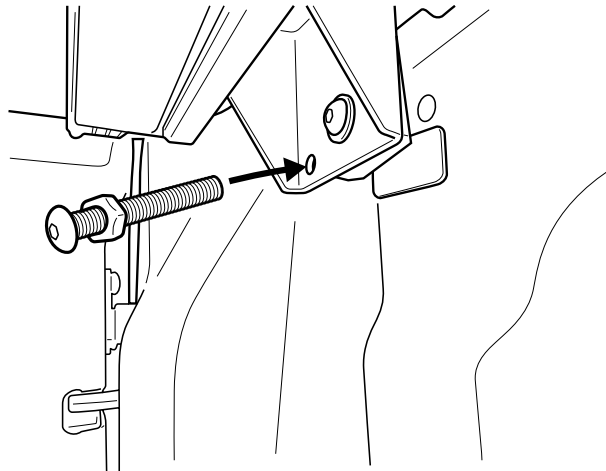

Side rail rubber must have a 1mm gap from the top of the tailgate in the closed position.

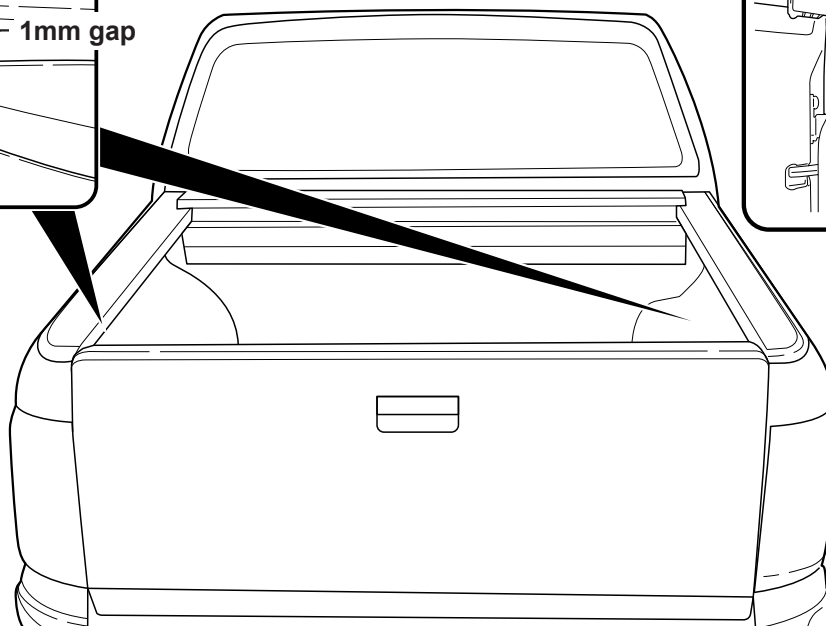
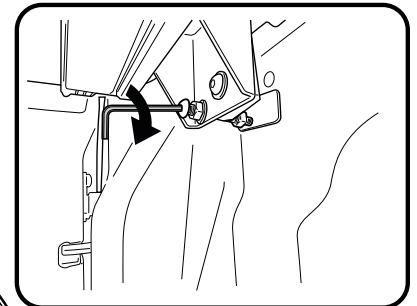
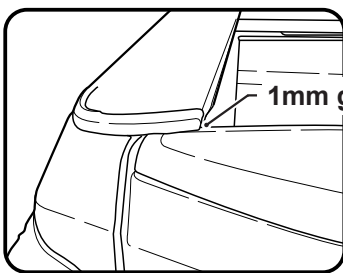

Drive the adjustment bolt in to lift the rear of the side rail till it clears the tailgate.

Fasten the M8 nut against clamp bracket.

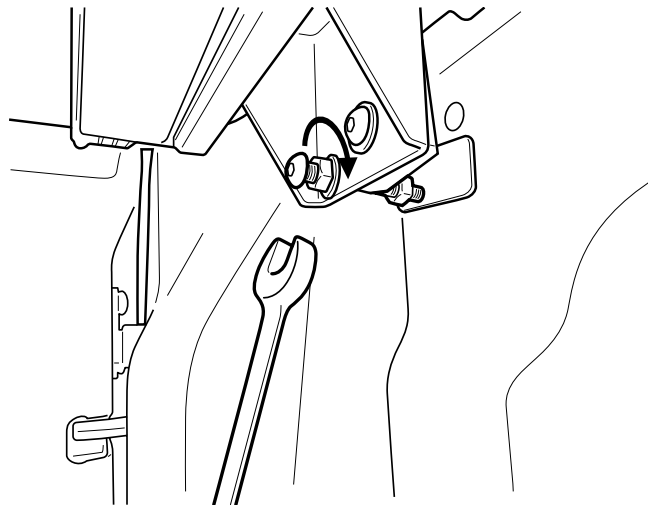

Install front drain pipes through pre-drilled holes of the canister. (RHS/LHS)



Note: With care push tube in.
Taking care pull the tube back
so it seals correctly against
the front panel of the tub.

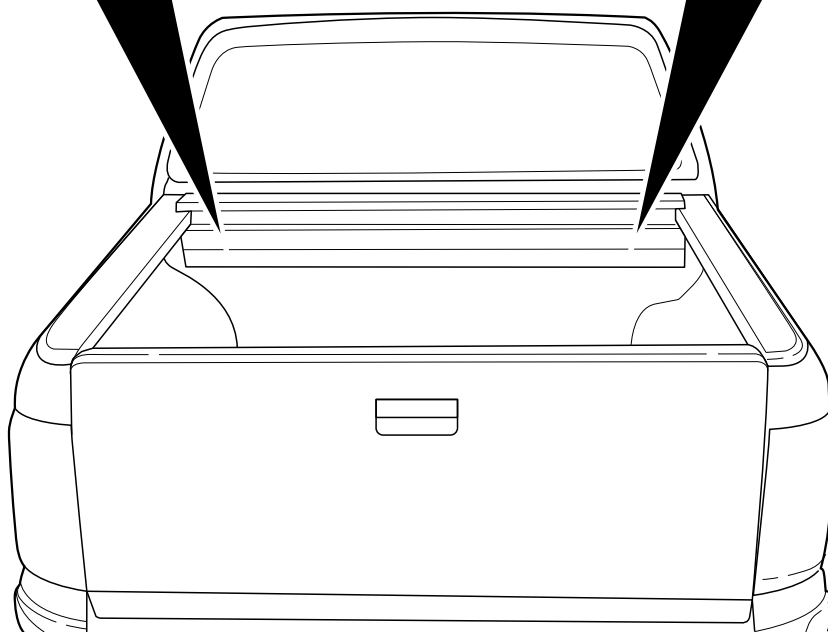
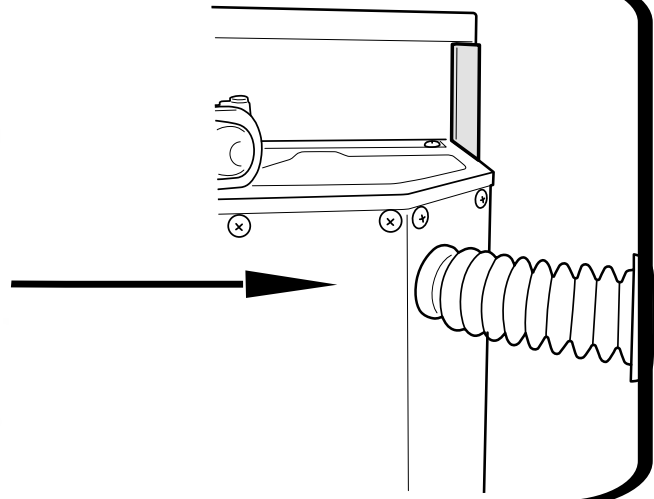
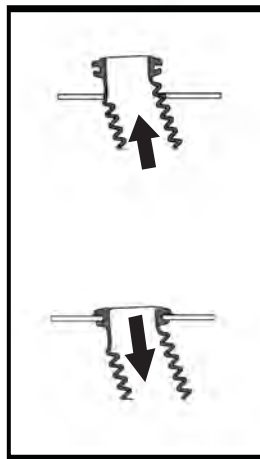

- a. Connect Battery loom S2.75 to Receiver loom.
- b. **Carefully** connect CI-Loom-short to Receiver loom.



Align connectors carefully to avoid pushing pins out.

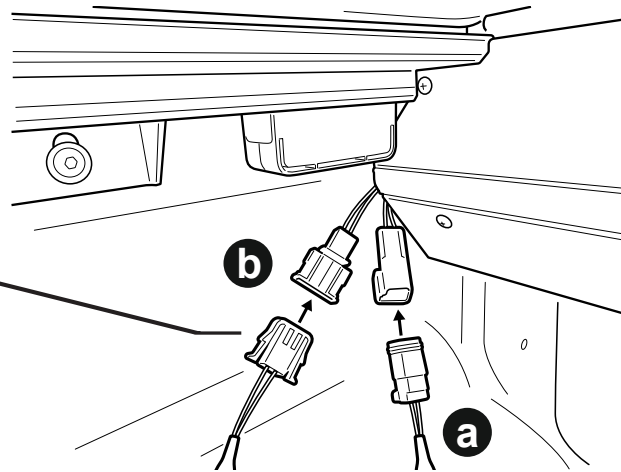

Operating instructions:

Press unlock on vehicle key fob to activate controller.

When vehicle is unlocked the side rail sensor buttons will be active to control.

When vehicle is locked the side rail sensor buttons will be inactive.

Touch & let go to open, touch & let go again to pause.

Touch & let go to close, touch & let go again to pause.

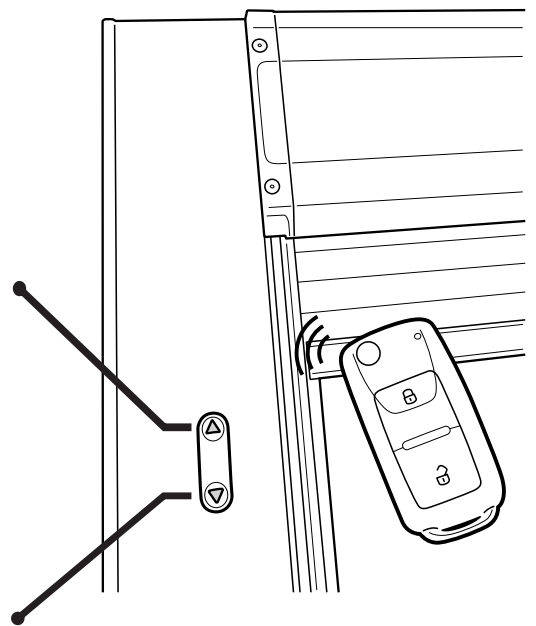

NOTE: 1. To wear in the Roll R Cover please fully open & close the cover approximately 15 times after install is complete.

2. Set your vehicle locking system to unlock all doors with one press of the factory remote unlock button. This setting can be found in your vehicle settings.