



WWW.HSPUTELIDS.COM

1300 441 498

Part No: NP18

Fitting Time: 45mins



NISSAN NP300

HSP TAIL LOCK

---

FITTING INSTRUCTIONS

## —GENERAL NOTES

---

- Read through the fitting instructions prior to installation of accessory.
- Ensure all recyclable components and packaging are discarded and recycled following local recycling regulations.
- Safely store and protect any removed vehicle components.

## —SAFETY NOTES

---

- Check that all work practices comply with safety standards.
- Please wear appropriate clothing and use safety equipment.

## —FITTING TIME

---



45mins

## —PARTS SUPPLIED

---

Part Description	Part Number	Quality/ Length	CHECK LIST
<b>TAIL LOCK ASSEMBLY</b>			
Main Bracket	NP18-A	1	
Rod	NP18-B	1	
Lever	NP18-C	1	
Actuator	ACT-01	1	
Wiring	CL-LOOM-LONG	1	
Patch Wiring	NP-PATCH	1	
<b>FASTENERS</b>			
Actuator Screws	36	2	
<b>OTHER</b>			
Cable Ties		5	
Rod Clips	37	2	
Fitting Instruction		1	

— STEP 1 —

Fit rod into actuator as shown.

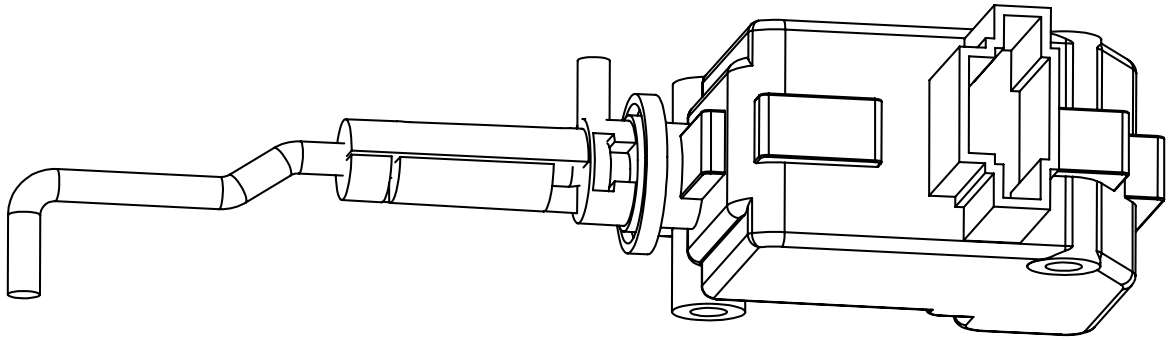

— STEP 2 —

Fit actuator to TailLock bracket as shown.

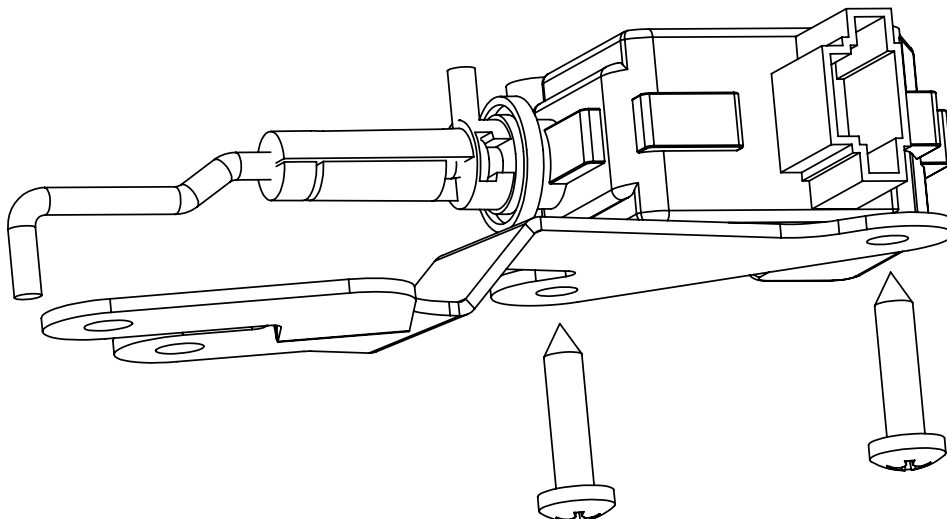

— STEP 3 —

Fit actuator to TailLock bracket as shown.

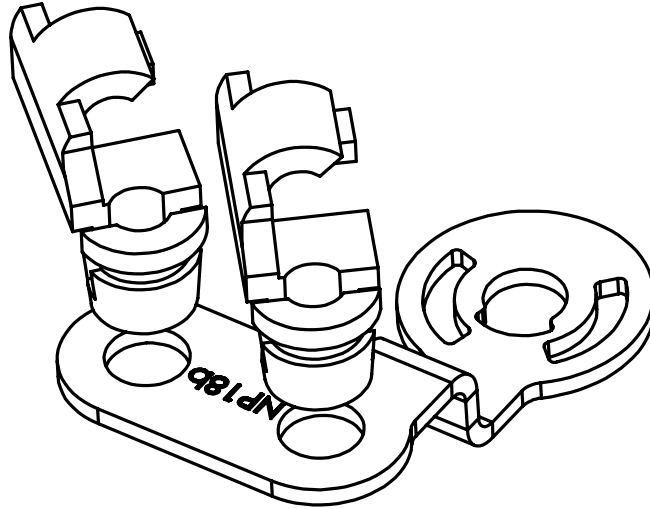

— STEP 4 —

Remove tail gate cover.

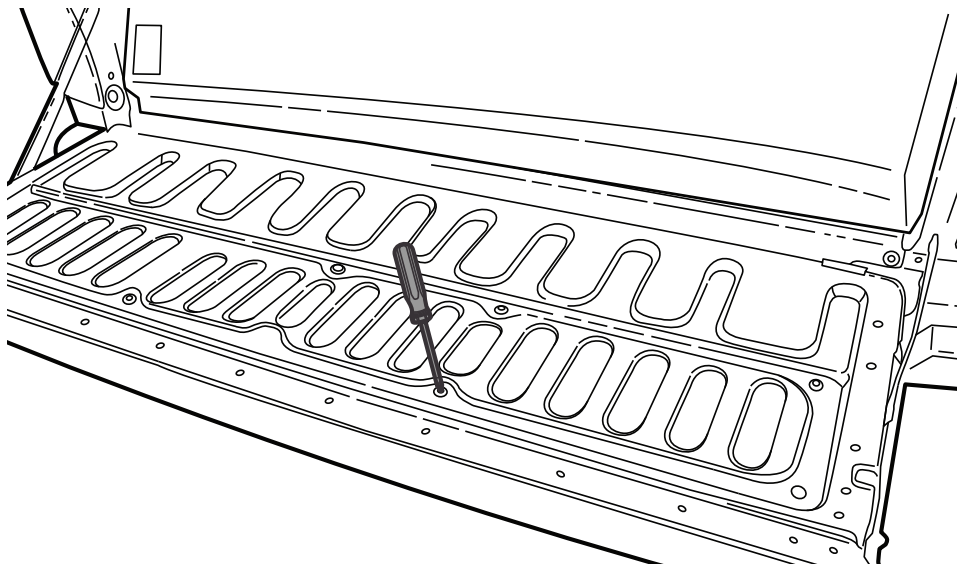

— STEP 5 —

Standard assembly.

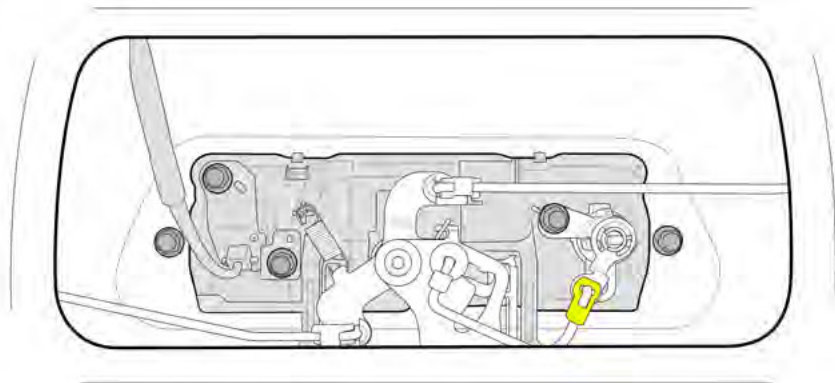

— STEP 6 —

Remove rod as shown.

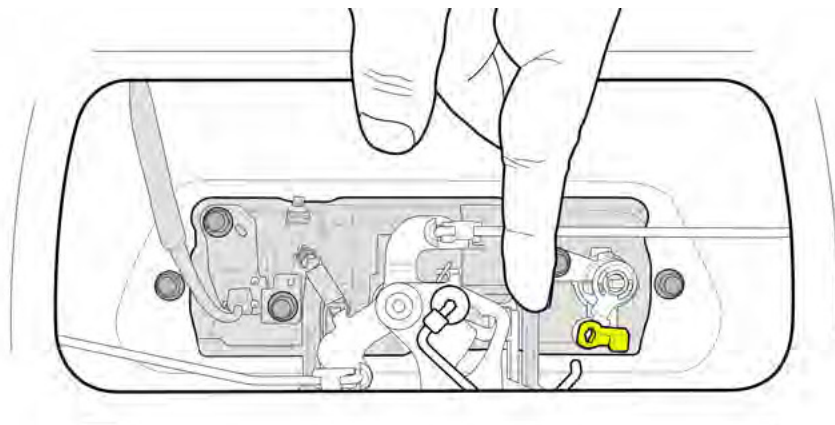

— STEP 7 —

Remove the cam as shown and by carefully removing the cert clip.

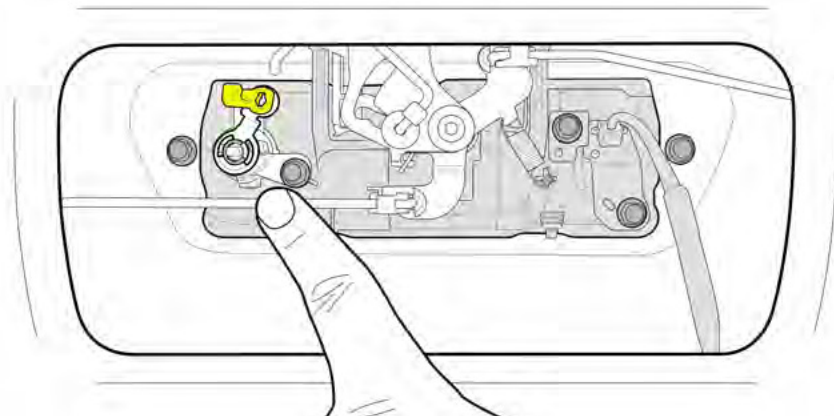

— STEP 8 —

Fasten the 2 bolts shown.

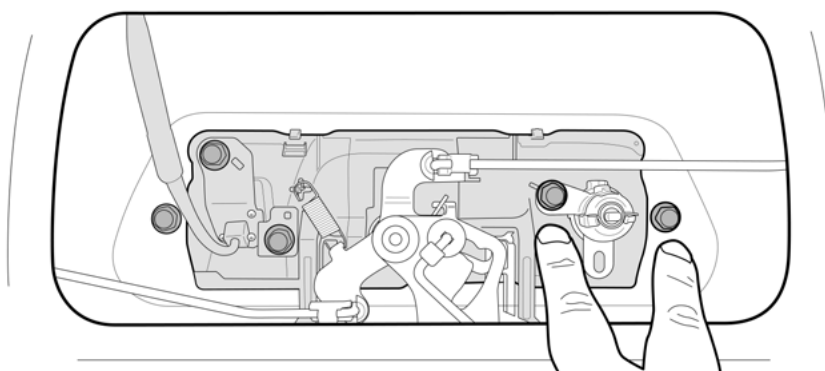

## — STEP 9 —

Install TailLock assembly as shown. Use cert clip removed from original cam to secure the new cam in place. Plug actuator rod as shown.

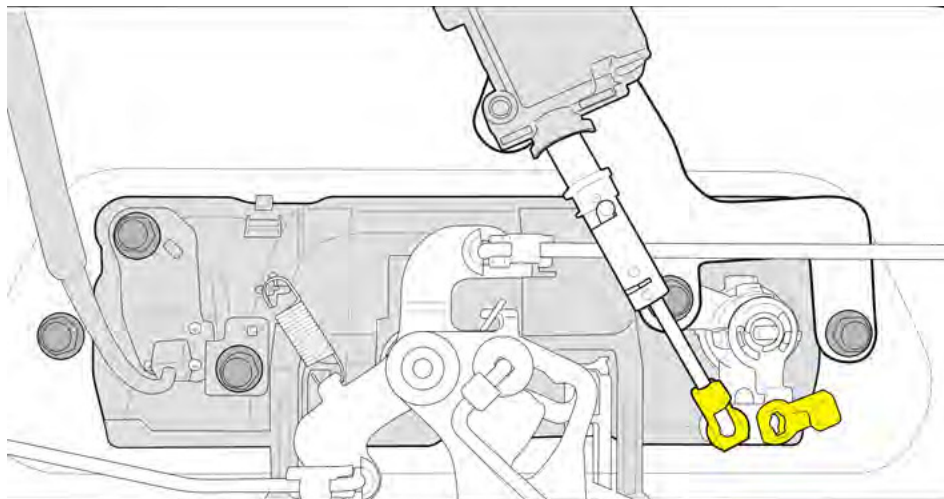

## — STEP 10 —

Attach rod to the new cam as shown.

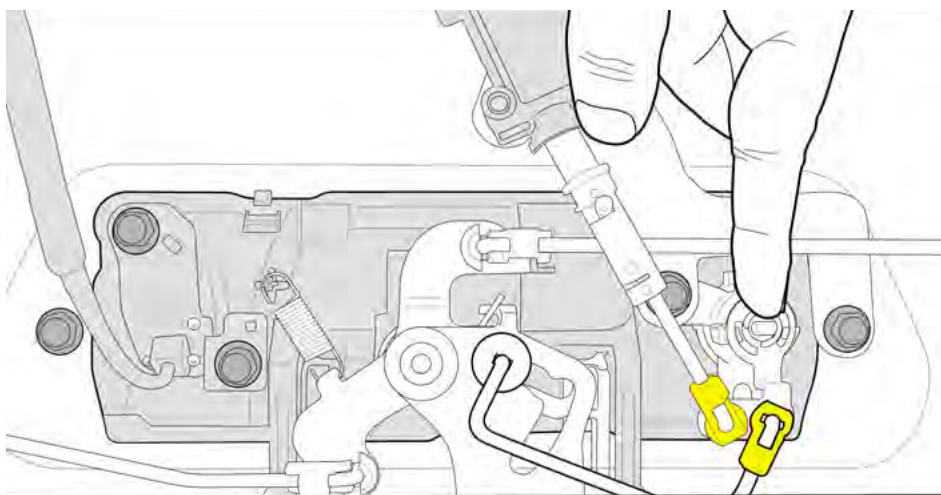

— STEP 11 —

Plug wiring to the actuator end.

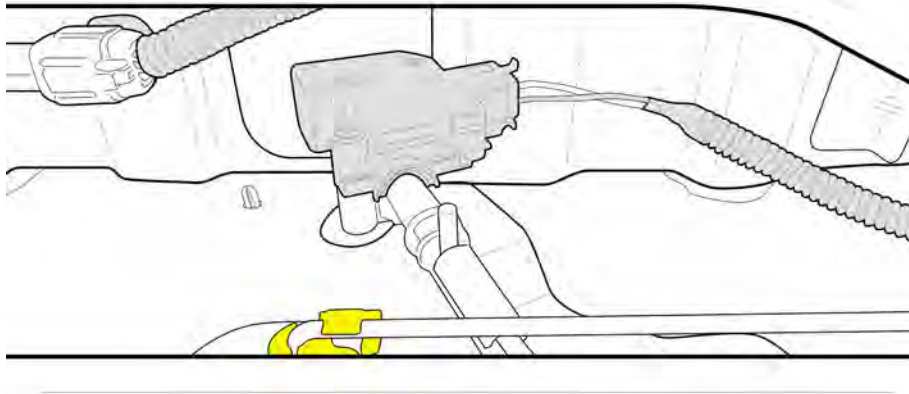

— STEP 12 —

Run wiring as shown over the passenger side chassis rail. Be sure to use cable ties provided every 400mm.

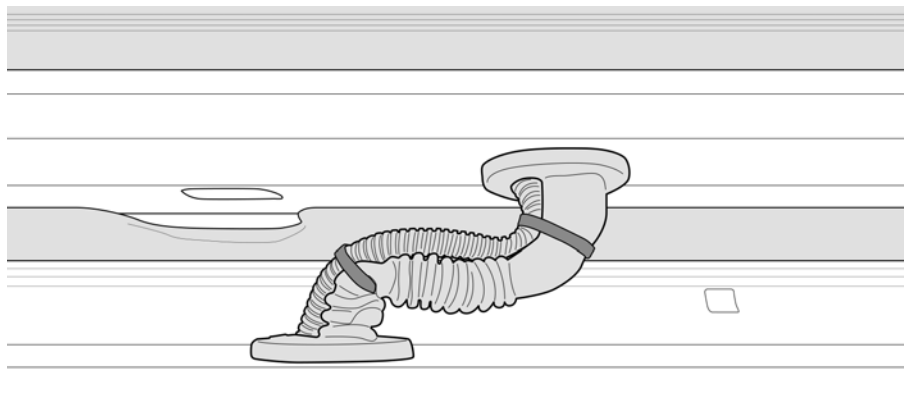



— STEP 13 —

Make a small hole under the front passenger side rail. Be sure to check for obstructions on both sides. Run wiring through small hole made.

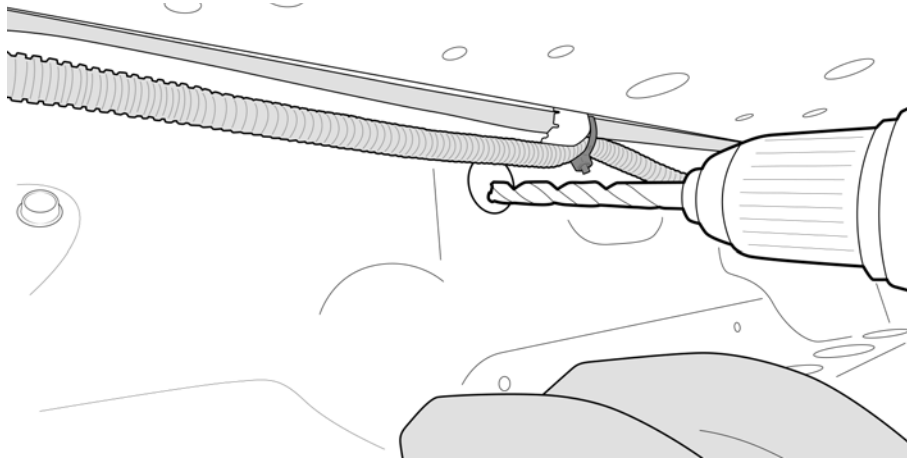

— STEP 14 —

Remove scuff plate.

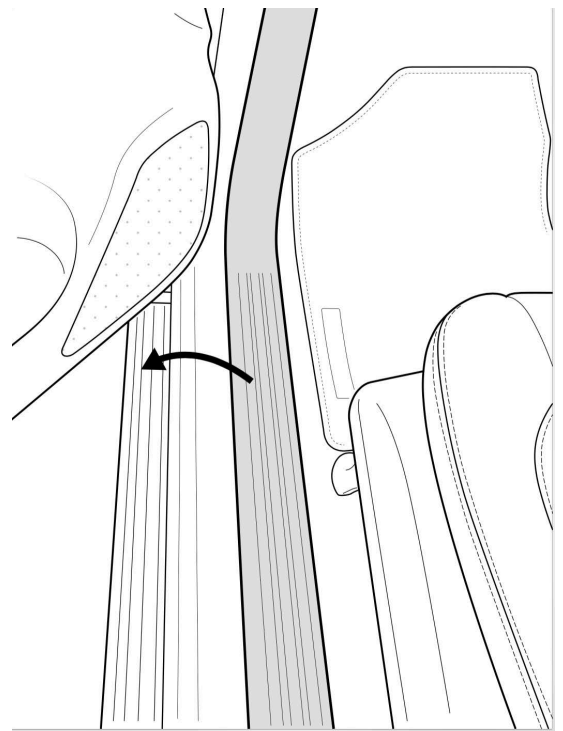

— STEP 15 —

Remove kicker panel.

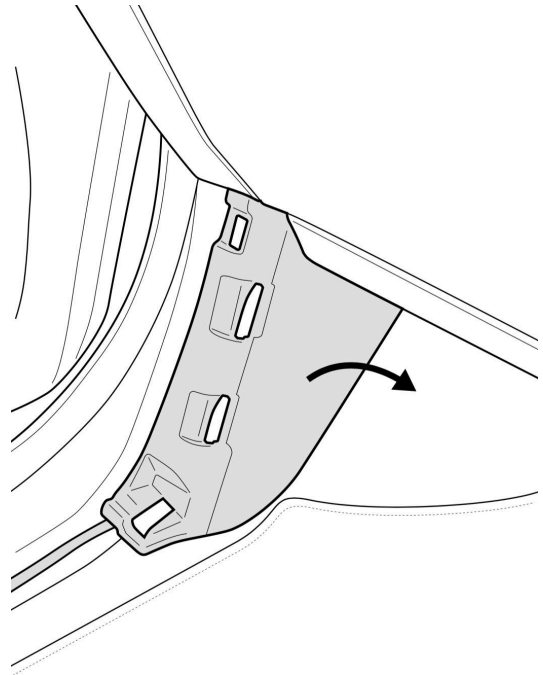

— STEP 16 —

Unplug indicated wiring and plug NP-PATCH wiring.

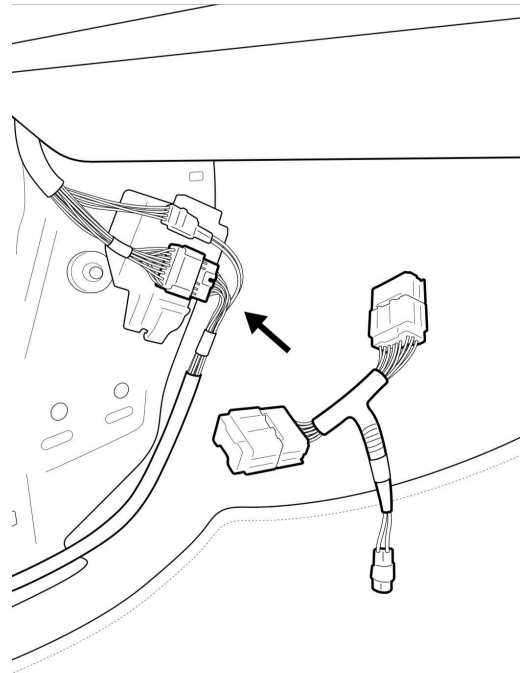

## — STEP 17 —

Plug CL-LOOM-LONG to PATCH wiring.

Cable tie overhang of wires and assemble all panels removed earlier.

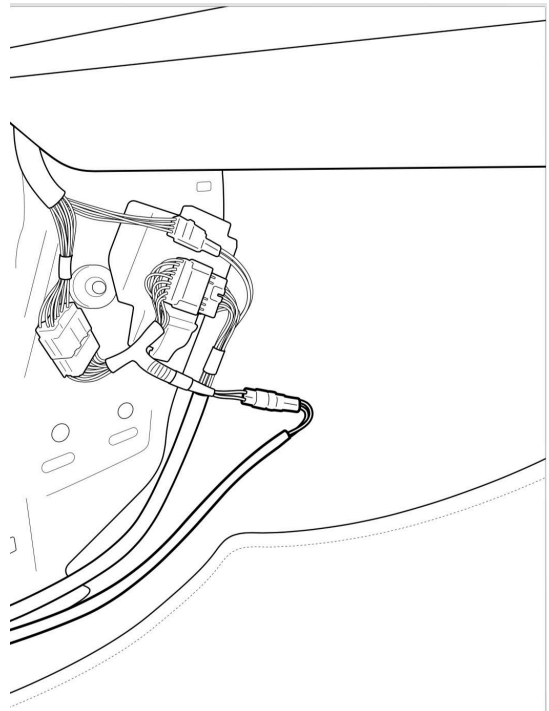

## — STEP 19 —

Connect scotch clips provided to central locking wiring running to the fuel cap as shown.

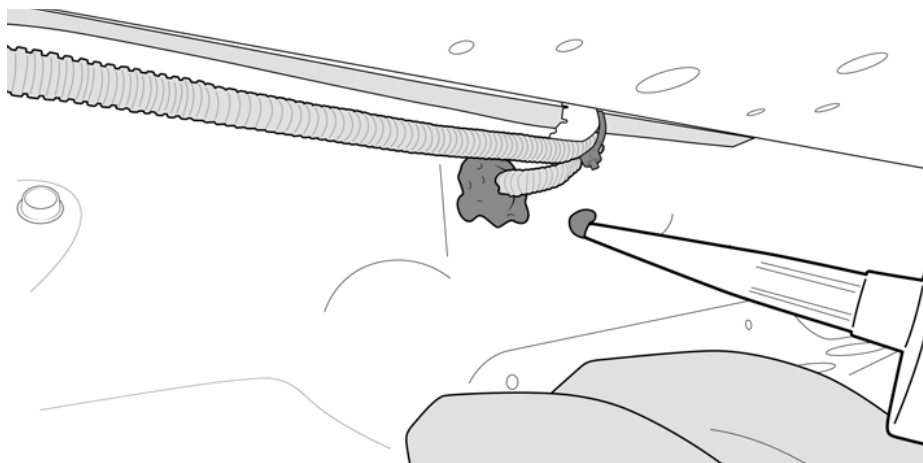

— FITTING COMPLETE —

---