

# RHINO-RACK

## Holden Colorado Isuzu DMAX - RIDB1

Fit Time: 1.5 Hours

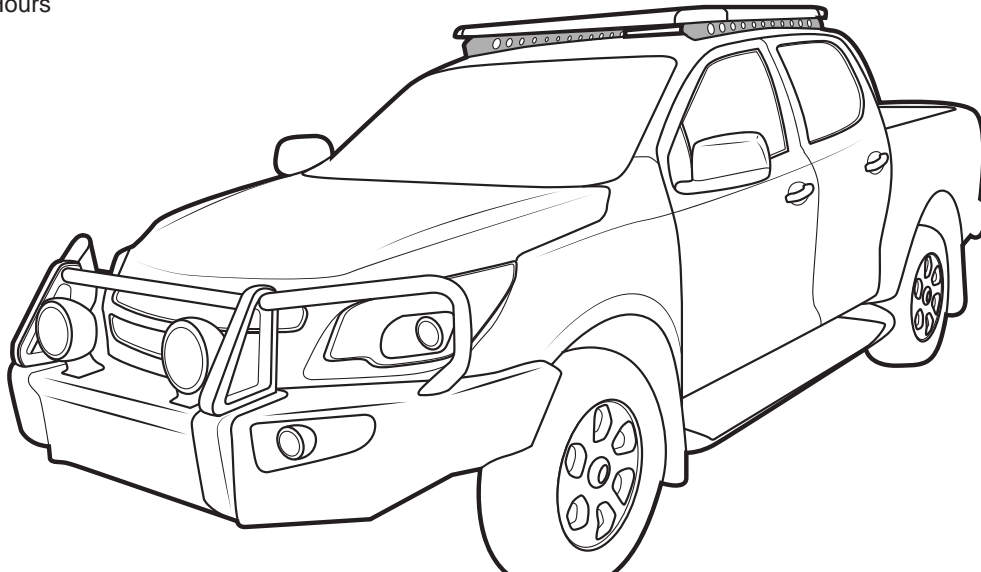

### IMPORTANT INFORMATION

#### Maximum carrying capacity:

Suitable Pioneers	On Road Cargo Allowance	Off Road Cargo Allowance	Static Allowance	Roof Allowance	Rack Weight
42100B	74.5kg / 164lb	54.5kg / 120lb	334.5kg / 737lb	100kg / 220lb	25.5kg / 56lb
45100B	72.5kg / 160lb	52.5kg / 116lb	332.5kg / 733lb		27.5kg / 61lb
41100	70kg / 155lb	50kg / 110lb	330kg / 728lb		30kg / 66lb

**Roof Allowance:** Total permissible weight attached to the roof of the car. This is inclusive of the weight of the roof rack system

**Cargo Allowance:** Total permissible weight allowed on top, and attached to roof racks whilst the vehicle is in motion

**Static Allowance:** Total permissible weight allowed on top, and attached to roof racks whilst the vehicle is stationary

Please refer to your vehicle manufacturers handbook for maximum carrying capacity. Always use the lower of the two figures. Load must be evenly distributed over the entire Pioneer. Weight of roof rack accessories is to be included in cargo allowance.

#### Torque settings

Unless stated otherwise in these instructions, all fasteners should be set to the following torque settings -

M6: 4-5Nm (3-4lbs/ft), M8: 8-10Nm (6-7.5lbs/ft) and M10: 16-18Nm (12-13lbs/ft).

#### Warning:

- Check Part No. and/ or Kit is correct for use with your vehicle
- Do not attempt to fit the rack system to your vehicle unless you fully understand these fitting instructions. Please direct any questions regarding fitting to the dealer from where the roof racks were purchased.
- **Use only non-stretch fastening ropes or straps.**
- The handling characteristics of the vehicle changes when you transport a load on the roof. For safety reasons we recommend you exercise extreme care when transporting wind-resistant loads. Special consideration must be taken into account when cornering and braking.
- Although the system is tested and approved to AS1235-2000 / ISO 11154, off-road conditions can be much more rigorous. Extreme care must be taken in off road conditions

#### Recommendations:

It is essential that all bolt connections be checked after driving a short distance when you first install your roof racks. Bolt connections should be checked again at regular intervals (once a week is enough, depending on road conditions, usage, loads and distances travelled). You should also check the roof racks each time they are re-fitted. Always make sure to fasten your load securely. Please also ensure that all loads are evenly distributed and that the centre of gravity is kept as low as possible and must be entirely contained within the extents of the roof racks.

#### Note for Dealers and Fitters:

It is your responsibility to ensure these fitting instructions are given to the end user or client

Rhino-Rack, 3 Pike St, Rydalmere  
NSW 2116, Australia  
(02) 8846 1900  
rhinorack.com.au

Document No: R945  
Prepared By: Kayle Everett  
Authorised By: Chris Murty

Issue No: 06  
Issue Date: 12/07/2018

These instructions remain the property of Rhino-Rack Australia Pty. Ltd. and may not be used or changed for any other purpose than intended.

# Holden Colorado Isuzu DMAX - RIDB1

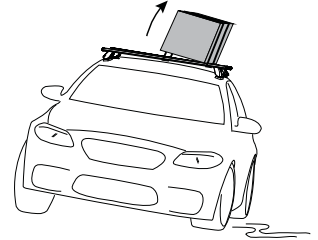
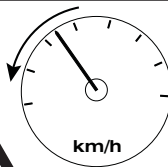
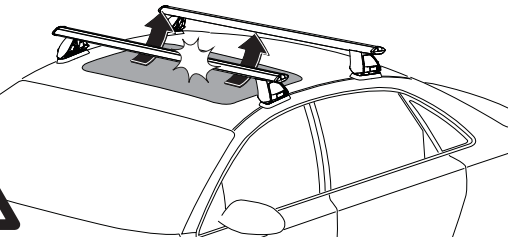
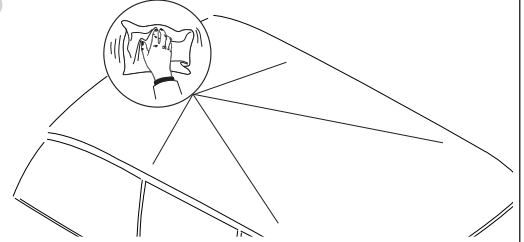
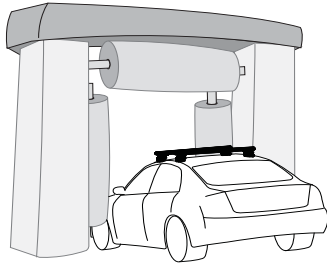
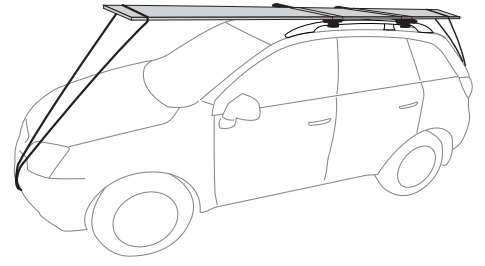
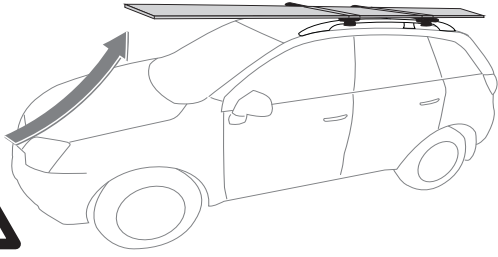

The handling characteristics of the vehicle changes when you transport a load on the roof. For safety reasons we recommend you exercise extreme care when transporting wind-resistant loads. Special consideration must be taken into account when cornering and braking.

Although the system is tested and approved to AS1235-2000 / ISO 11154, off-road conditions can be much more rigorous. Extreme care must be taken in off road conditions

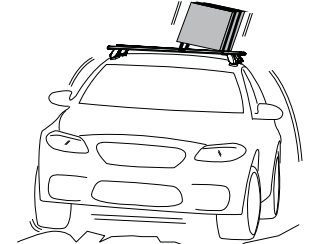
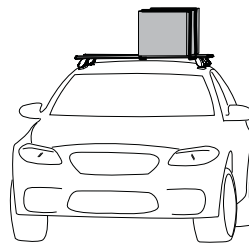

**System Weight: 25.5 - 30kg**

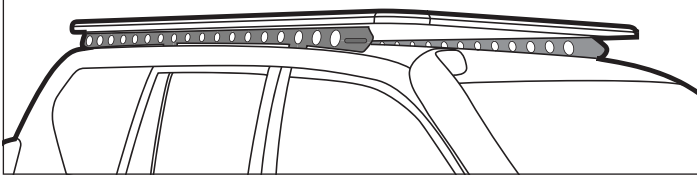

**Static Load Rating:** refer to front page



**Ensure Ladder is well supported on the ground to help support tent. Take extreme caution when climbing heights above 1.2m/4ft.**

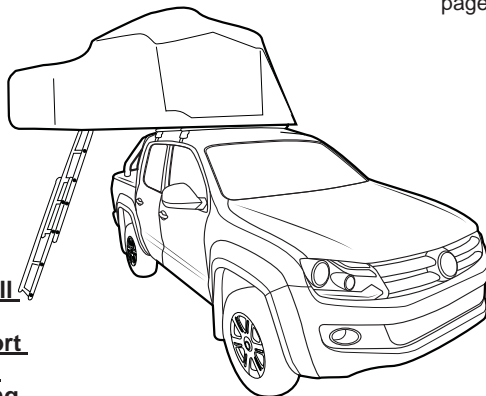

Paddle/ Surfboards should be fixed to the front of the vehicle.

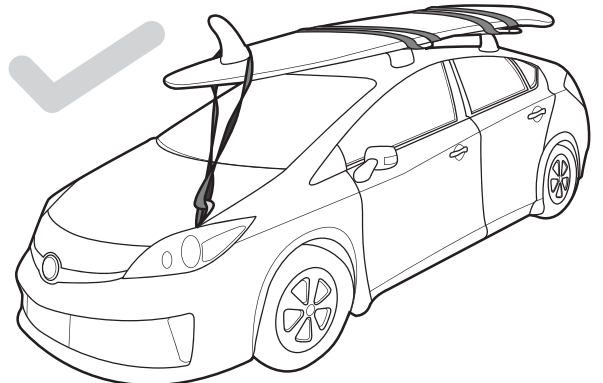

# Holden Colorado Isuzu DMAX - RIDB1

## Parts List

Item	RIDB1	Qty	Part No.
1	Colorado/DMAX Backbone LH	1	CA1513
2	Colorado/DMAX Backbone RH	1	CA1514
3	Butyl Patch 40x25mm 7mm Hole	4	CA1260
4	M8 Channel Nut	4	N003
5	M8x19x2.5mm Flat Washer	4	W043
6	M8 Spring Washer	8	W019
7	M8x20mm Hex Setscrew	4	B020-BLK
8	M8x20mm Socket Head Screw	4	B050
9	M8x17mm Flat Washer	4	W020
10	Short 6mm Allen Key	1	H050
11	Instructions	1	R945

For use with Pioneer 42100 Pioneer range sold as separate.

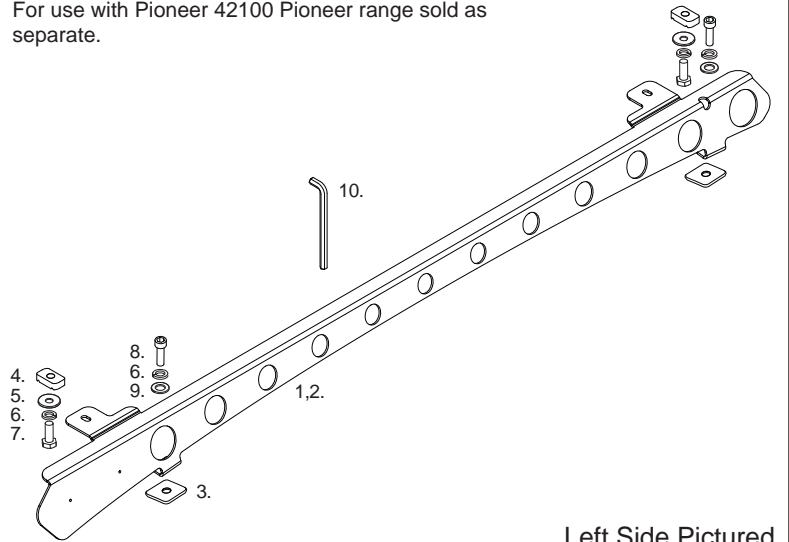

Left Side Pictured

### Tools Required:

1. 13mm Spanner
2. Marker
3. Nylon Scrape
4. Cutters
5. 6mm Ball End Allen Key
6. Trim Removal Tools

## Holden Colorado Z71 Rail Removal

- 1 For Vehicles without Roof Rails - Skip to Step 4. (Note for models with roof rails be sure to have SUB0709 kit on hand).

Remove plastics covers from roof rails. Extreme caution must be used when removing cover and rail. The roof panels are extremely soft and can easily be deformed.

The plastic covers are fixed using 4 internal plastic clips. Disengage the clips by first levering the inside of the cover outwards, using a second trim removal tool, place under the cover and slide horizontal whilst pulling up. **Do NOT lever against body work.**

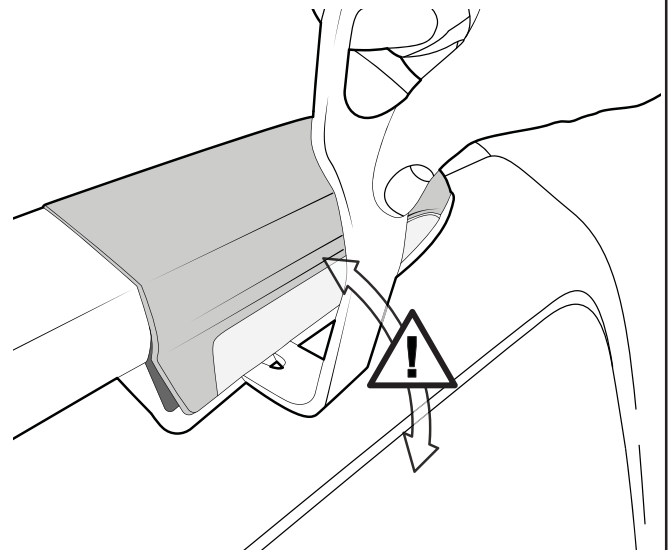
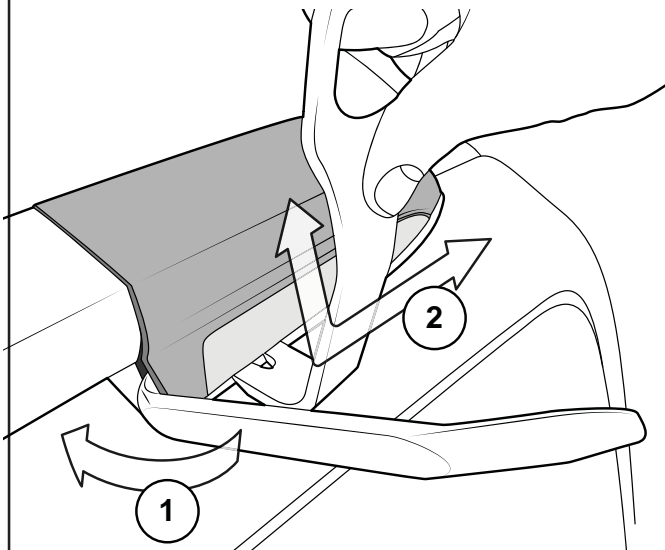

INSIDE

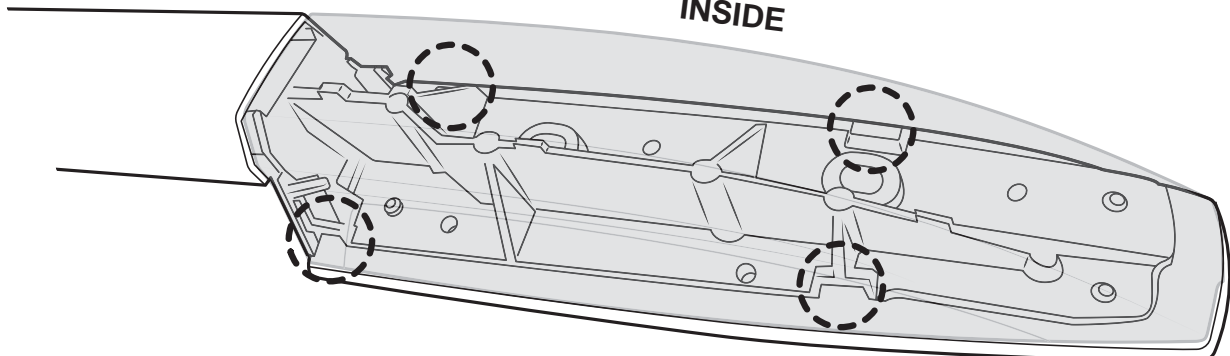

# Holden Colorado Isuzu DMAX - RIDB1

**2** Remove Torx bolts using T50 Torx key.

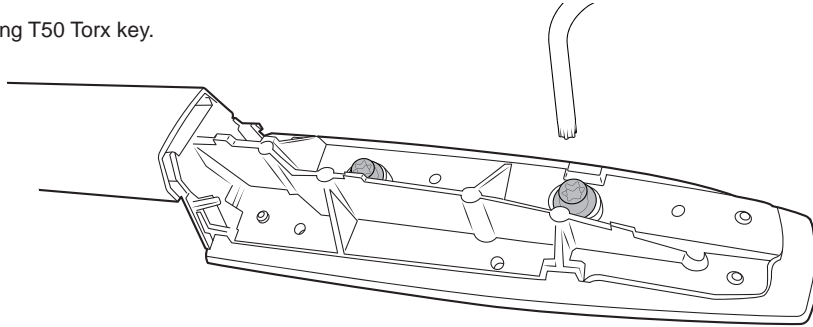

**3** Once bolts have been loosened and removed - ⚠ LIFT rail vertically to remove. Do NOT roll rail backwards or forwards to remove as this will damage the bodywork. The gutter strip under the roof rail is factory cut and will NOT extend to the feet of the Backbone. A gap in the gutter strip will be present. Install SUB0709 kit into the open threads. Once complete - move to step 7.

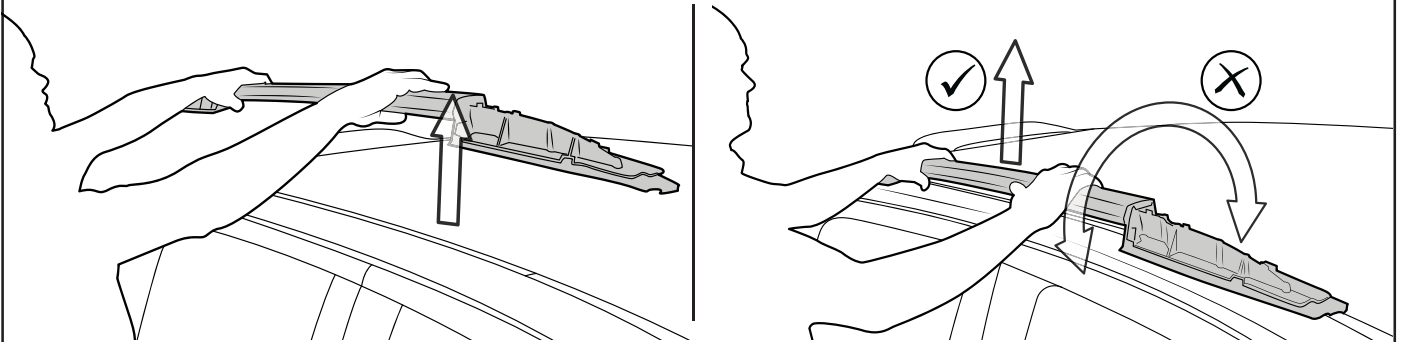

## Instructions

**4** Starting at the Door Jamb measure out to the locations below and use a marker to create cutting references on the Ditch Mould.

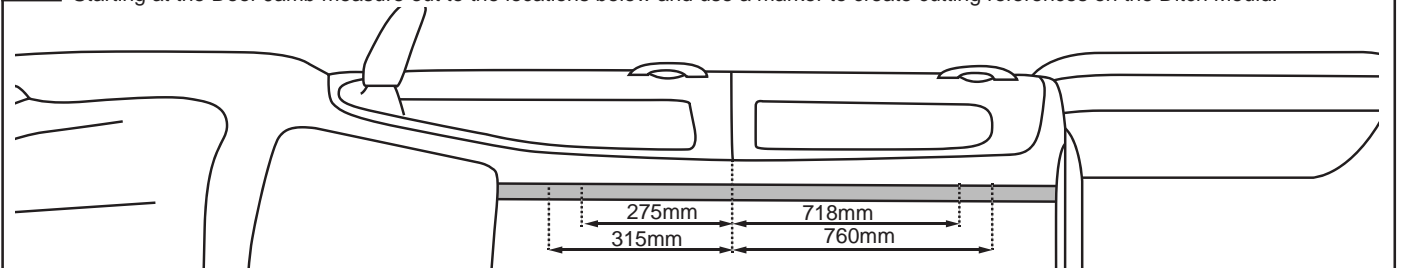

**5** With the assistance of a second person, peel back the inside edge of the gutter at the area where the Ditch Mould needs to be cut. Carefully, using sharp cutters, cut the inside edge of the Ditch Moulding.

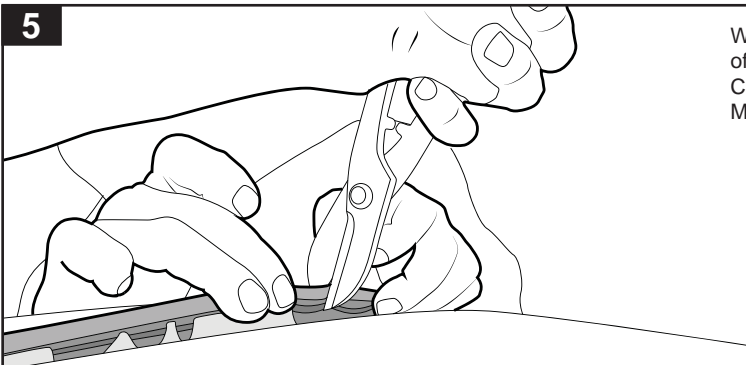

Use extreme caution when using cutters. Ensure the tool does not touch any vehicle paintwork.

**6** Repeat step 2 - pushing the ditch moulding forward and completing the remainder of the cut. Repeat for all marks on ditch moulding prepared in Step 4

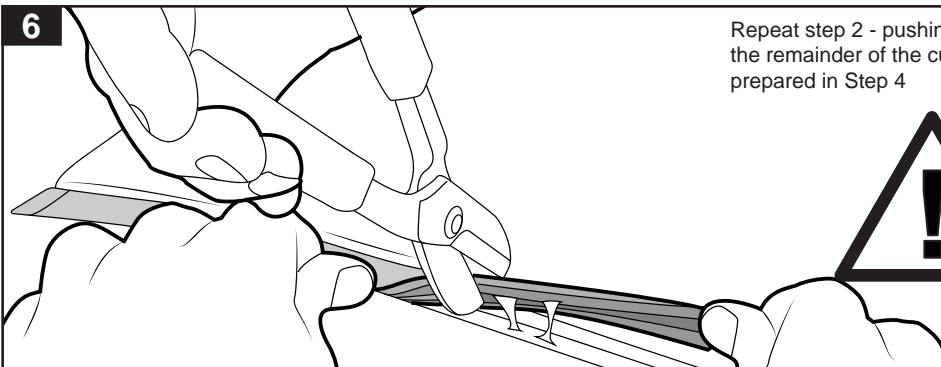

Use extreme caution when using cutters. Ensure the tool does not touch any vehicle paintwork.

# Holden Colorado Isuzu DMAX - RIDB1

**7** For Holden Colorado Only (see step 8a,b and c for Isuzu DMAX): Locate the four Factory Mount Points in the Ditch, these will be covered by painted Butyl Patches. Using the Allen Key provided, carefully push through the Patches and expose the threads below. Remove any material within. Using an M8 Socket Screw, test all exposed threads for binding. Clean threads if required.

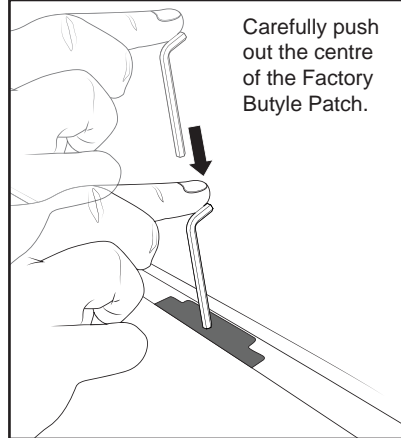
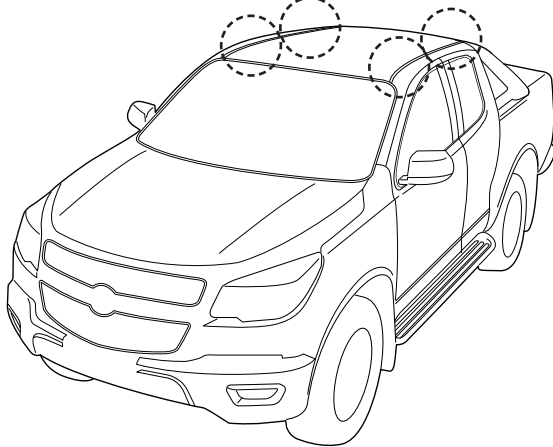

Carefully push out the centre of the Factory Butyle Patch.

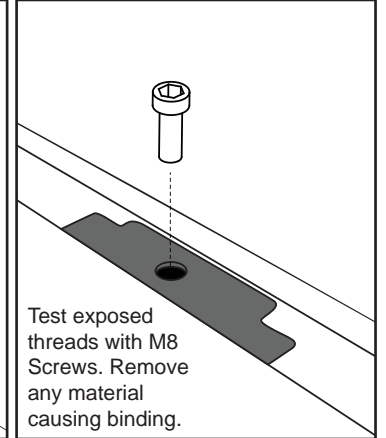

Test exposed threads with M8 Screws. Remove any material causing binding.

**8a** For Isuzu D-MAX: 1 - Measure back along the Ditch from the front of the vehicle, 350mm as shown. Spot drill the centre of the Ditch at this point with a 3mm Drill Bit. Measure back from here a further 1032mm and spot drill at that point. 2 - Open out these spot marks with a 7mm Drill Bit.

Top View:

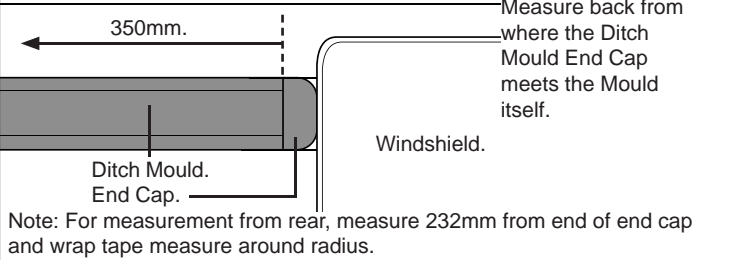

Note: For measurement from rear, measure 232mm from end of end cap and wrap tape measure around radius.

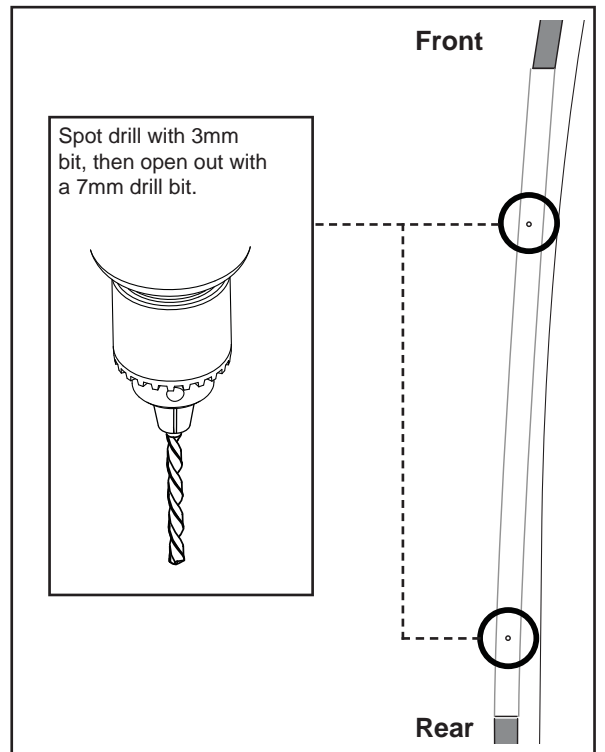
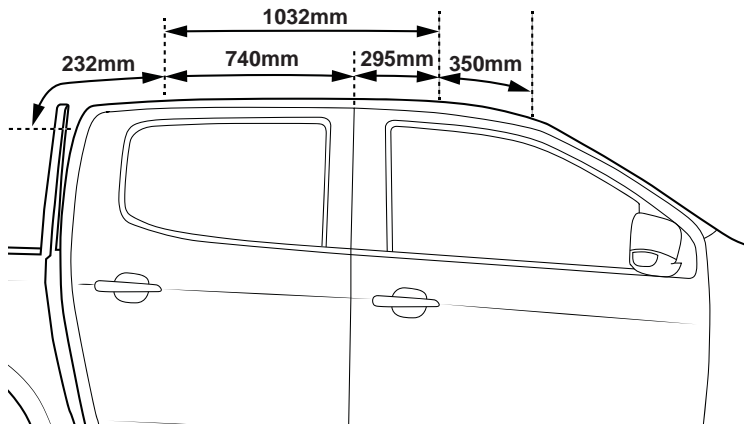

Spot drill with 3mm bit, then open out with a 7mm drill bit.

**8b** Dye Grind the opened holes from the previous steps. This will expose the Nutserts below.

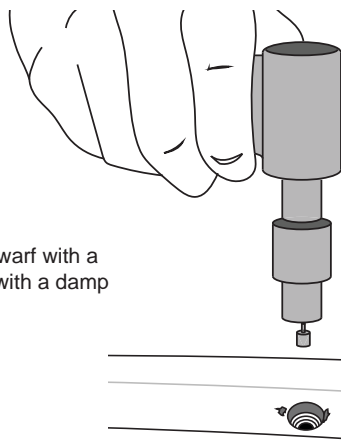

Note: Remove all swarf with a vacuum then wipe with a damp microfibre cloth.

**8c** Apply a liberal amount of cold galvanizing solution to the inside and surrounds of all holes. Allow cold galvanizing solution to dry as per instructions (5-10 mins).

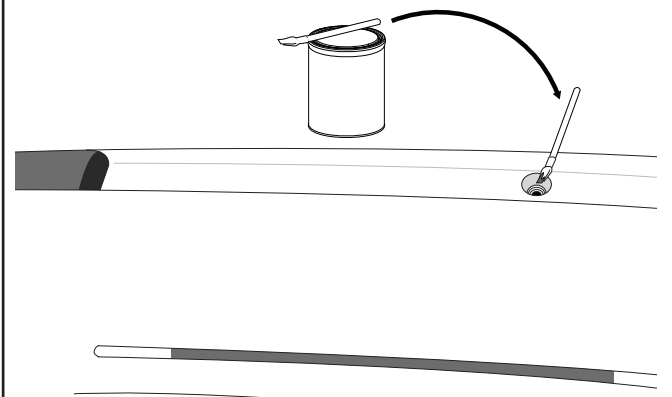

# Holden Colorado Isuzu DMAX - RIDB1

- 9** Remove one side of protective tape from the Butyl Patches provided. Place carefully over the exposed threads. Remove the top layer of protective tape from the installed Patches.

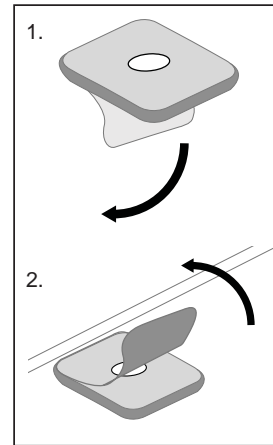
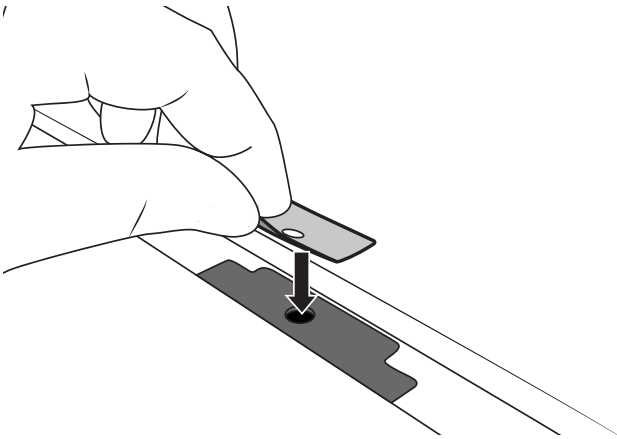

- 10** Place the Backbone onto the vehicle. Be sure to use correct orientation. 1: Finger tighten in place with M8 Socket head Screws, M8 Spring and Flat Washers. 2: Tighten with Allen Key. The hardware can be accessed easily from the outside of vehicle as shown with a long ball end allen key. Be sure all fixtures are secure.

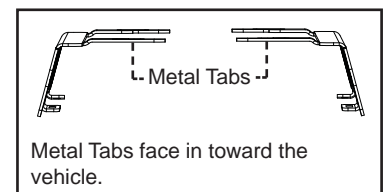
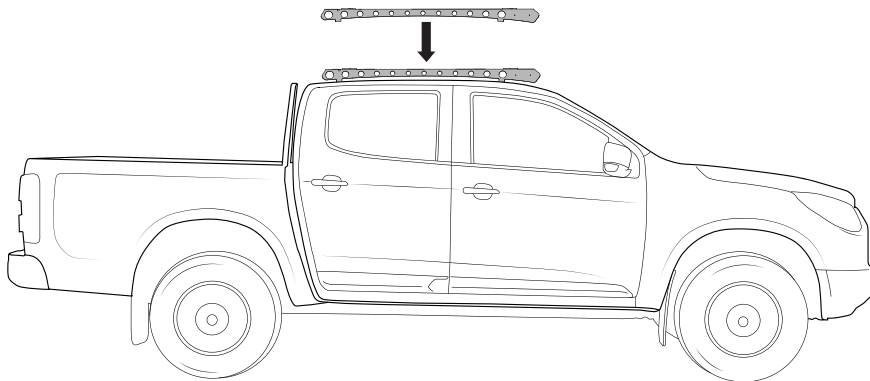
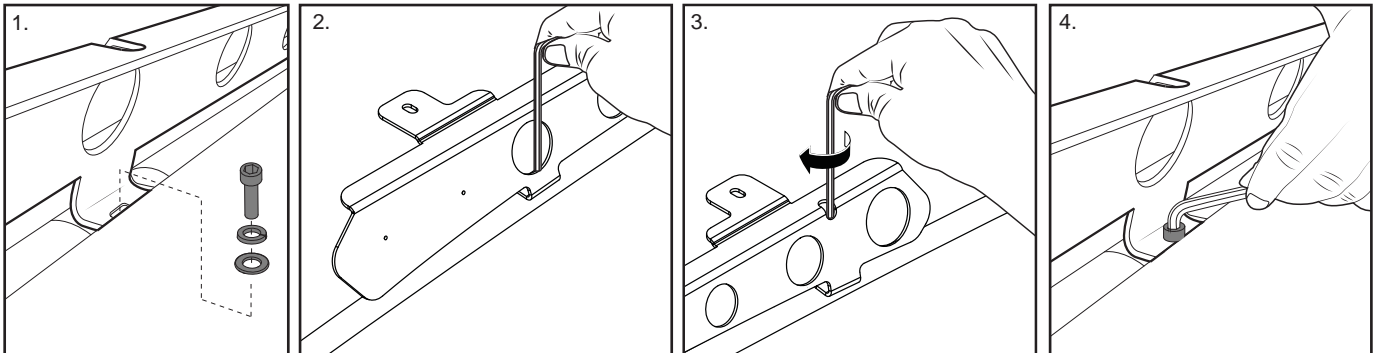

- 11** Repeat previous steps for securing opposite side Backbone rail.

Ensure both Assemblies are securely positioned on the car. Check each bolt before proceeding to attaching the Pioneer Platform to the Backbone.

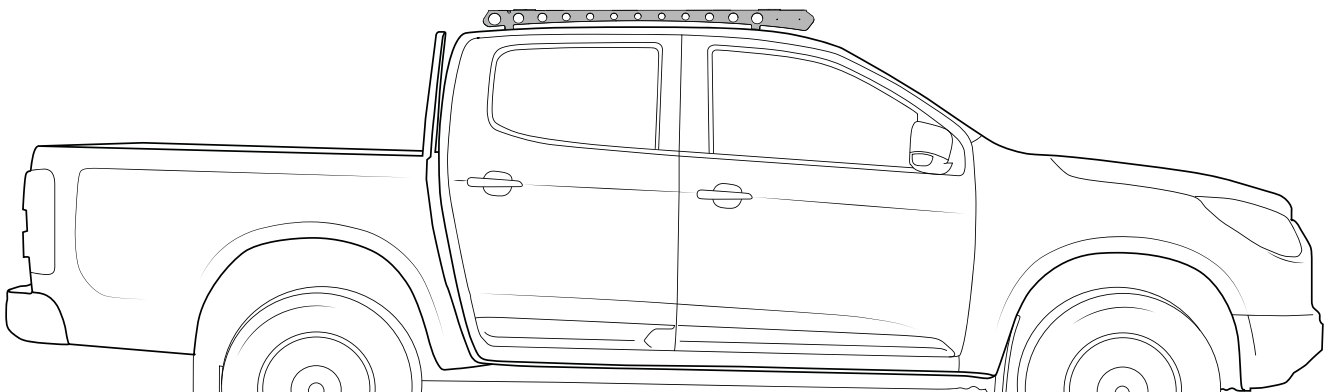

# Holden Colorado Isuzu DMAX - RIDB1

- 12** Assemble M8 hardware as pictured below. Complete this for the six tabs on top of the backbone rails (2 each rail).

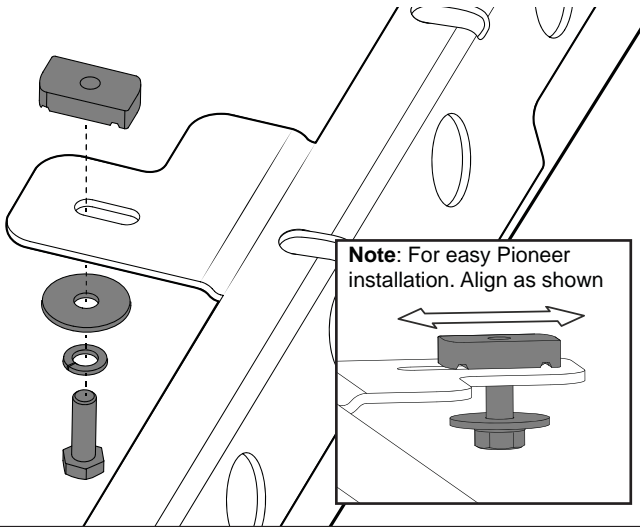

- 13** Install Pioneer Underbars with slots indicated (42100  
**REAR:** 125mm from Rear (using slots)  
**FRONT:** 100mm from Front (drill)

The rear slot will have to be drilled with an 8.5mm drill bit. For detailed underbar installation instructions, refer to Pioneer fitting instructions.

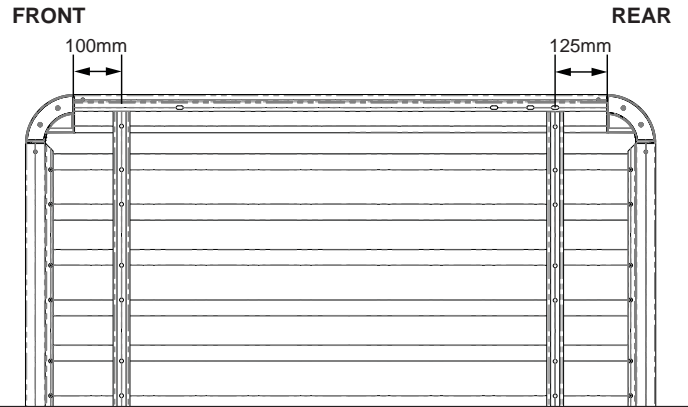

- 14** After underbars have been correctly fitted, place the Pioneer Platform on top of the Backbone. Align the underbars with the top tabs and ensure the M8 hardware fits into underbar channel.

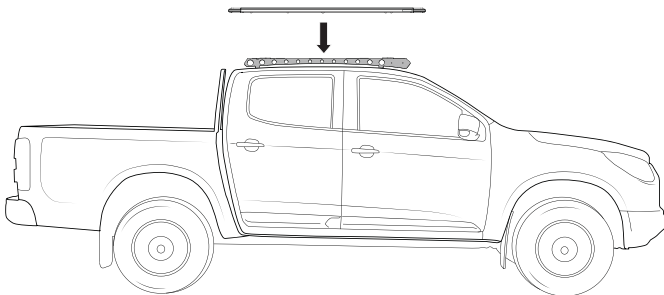

- 15** Once Pioneer Underbars have been aligned properly, tighten all M8 hardware using 13mm socket wrench or 13mm spanner. Ensure channel nut has rotated within Pioneer underbar and is fixing Pioneer securely.

