



WWW.HSPUTELIDS.COM

1300 441 498

Part No: H18-1

Fitting Time: 45mins



TOYOTA HILUX

HSP TAIL LOCK

FITTING INSTRUCTIONS

—GENERAL NOTES

- Read through the fitting instructions prior to installation of accessory.
- Ensure all recyclable components and packaging are discarded and recycled following local recycling regulations.
- Safely store and protect any removed vehicle components.

—SAFETY NOTES

- Check that all work practices comply with safety standards.
- Please wear appropriate clothing and use safety equipment.

—FITTING TIME



45mins

—PARTS SUPPLIED

Part Description	Part Number	Quality/ Length	CHECK LIST
TAIL LOCK ASSEMBLY			
Main Bracket	H18-A	1	
Eyelet	H18-B	1	
Actuator	ACT-01	1	
Wiring	CL-LOOM-LONG	1	
Patch Wiring	X-PATCH	1	
FASTENERS			
Actuator Screws	36	2	
Push on Clips	41	1	
OTHER			
Cable Ties		5	
Fitting Instruction		1	

— STEP 1 —

Fit Eyelet into actuator striker.

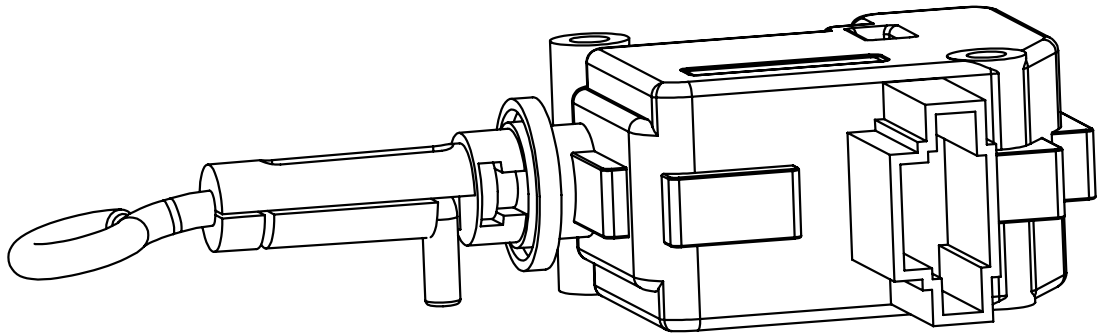

— STEP 2 —

Assemble the actuator to the TailLock bracket.

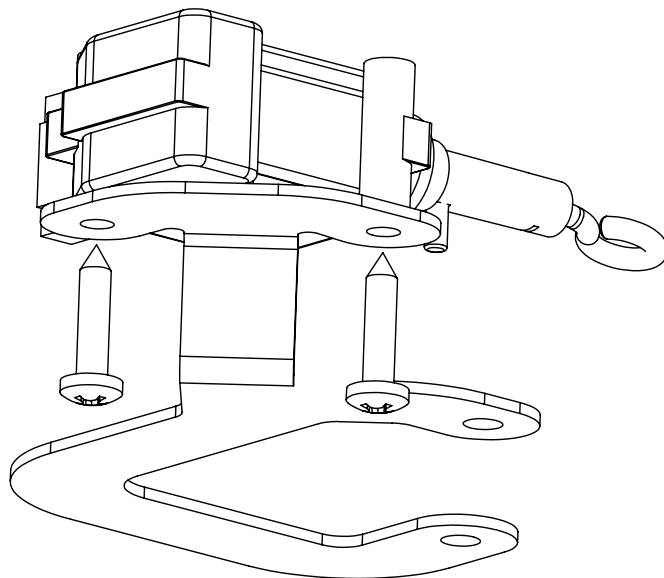

— STEP 3 —

Remove tail gate cover.

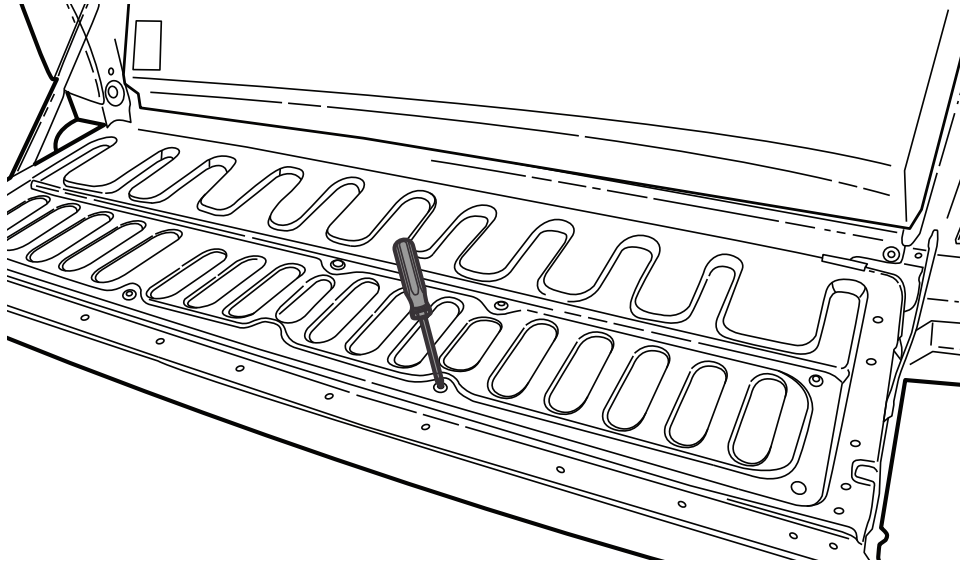

— STEP 4 —

Remove arm rods (b)

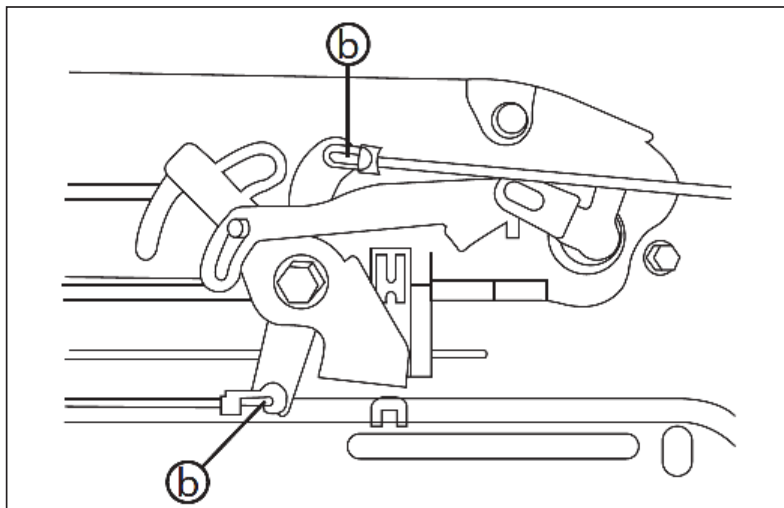

— STEP 5 —

Unfasten bolts (i)

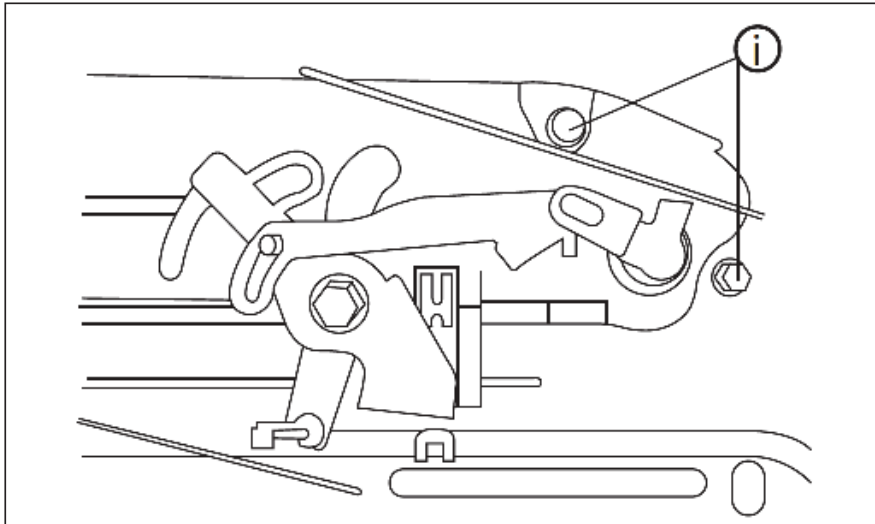

— STEP 6 —

Place TailLock assembly as shown and fasten bolts (i). Fit push on clip (b) as shown.

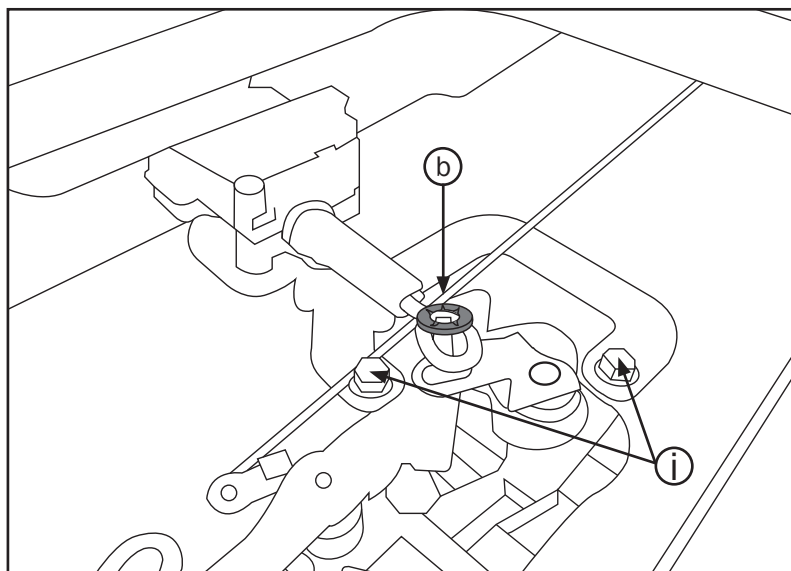

— STEP 7 —

- 1) Plug CL - Loom-long wiring to actuator end.
- 2) Route the CL -Loom-long harness (1) out of the tailgate and underneath the vehicle.

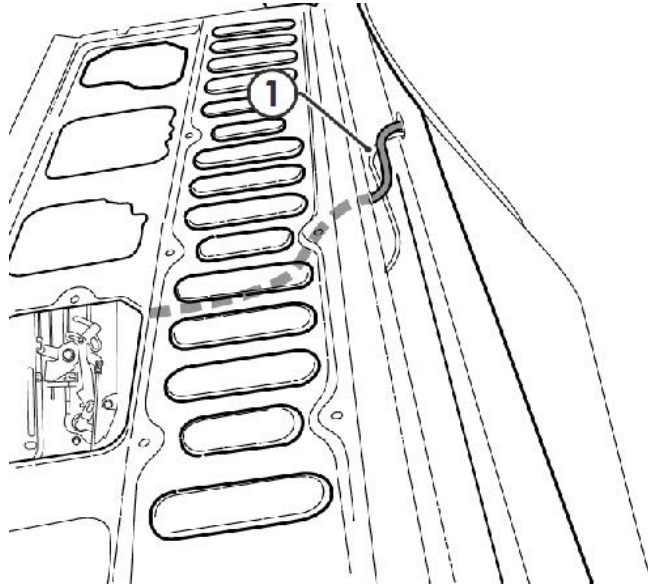

— STEP 8 —

- 1) Route the CL - Loom-long harness along the LHS chassis rail to the grommet underneath the LHS front seat.
- 2) Secure the wiring every 400mm with the cable ties provided.
- 3) Make a slit in the grommet, pass the actuator wiring harness through the grommet (1) and using silicon, reseal the slit.

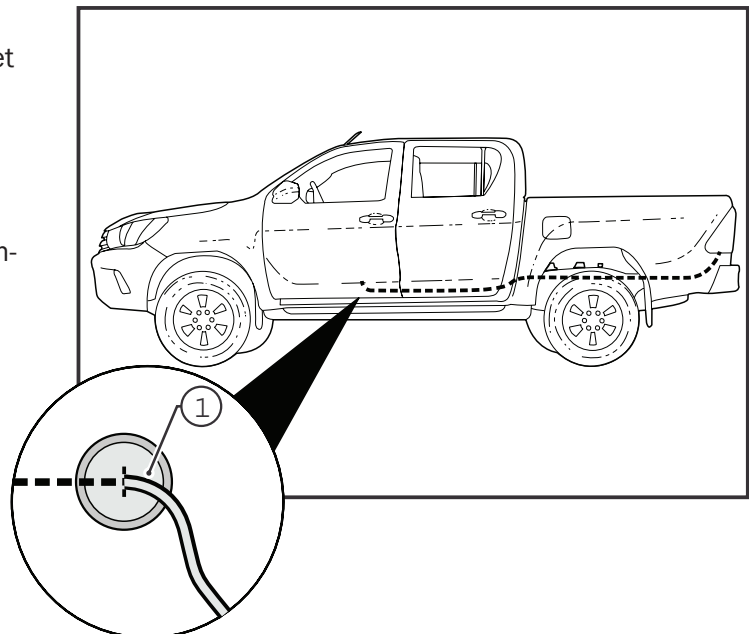

— STEP 9 —

At the front passenger side foot well area:

- Remove front passenger scuff plate (1)
- Remove the kick panel trim nut (2)
- Remove the kick panel (3)

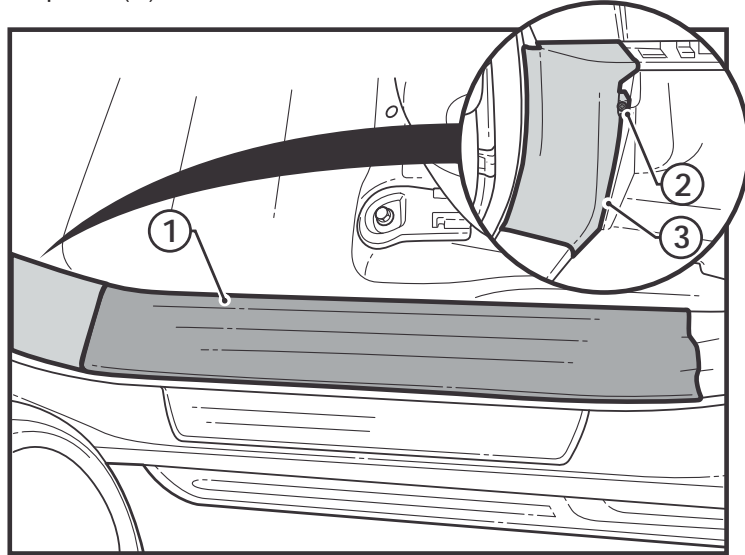

— STEP 10 —

Continue routing CL - Loom-long wiring harness (1) through the grommet, along the door sill up to the LHS kick panel, following the existing vehicle harness.

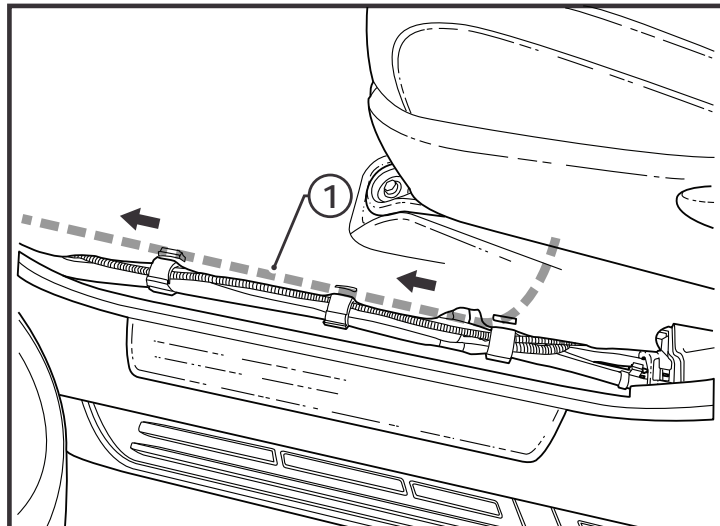

— STEP 11 —

Locate and disconnect the 20-way hybrid junction connector (1) in the passenger side kick panel area.

Identify the two Lock/Unlock terminal wires as shown:

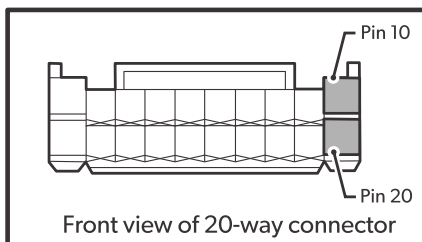

Connector Pin 10: Lock / Black Wire
Connector Pin 20: Unlock / White Wire

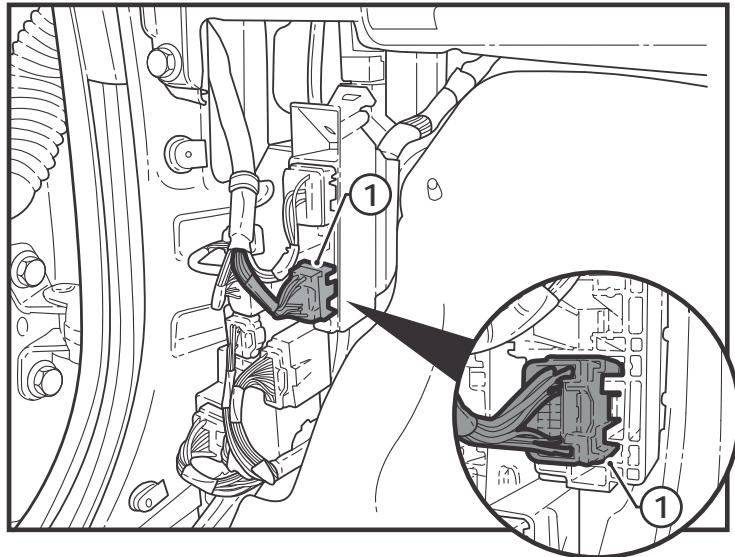

STEP 12

Using a precision screw driver, unclip the connector secondary lock (1). Carefully remove the two Lock/Unlock wires from the rear of the connector using a precision screw driver.

House the Blue and Red lamp vehicle x-patch harness terminals (2) into the rear of the connector cavities in the positions show:

Red Wire Upper Cavity (3)
Blue Wire Lower Cavity (4).

Push the 20-way connector secondary lock (1) into place to retain terminals.

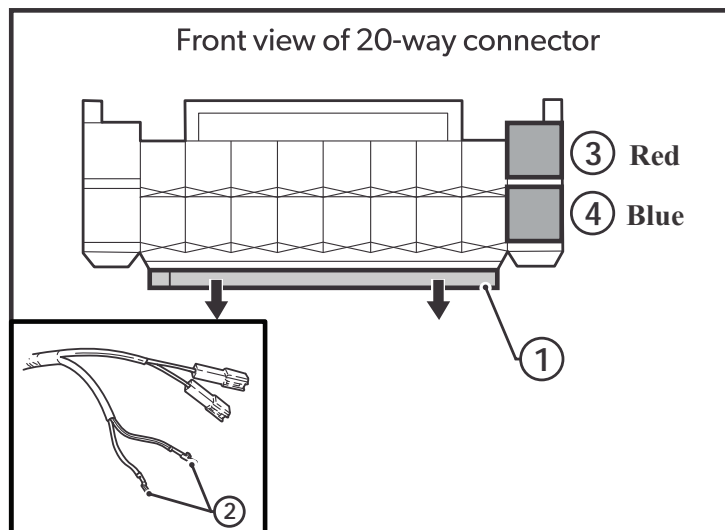

— STEP 13 —

House the lock/unlock wiring terminals, previously removed from the vehicle harness (1) into the supplied 2-way male connector (2) as shown, now Connect the actuator wiring harness to the vehicle patch harness 2-way connector (3).

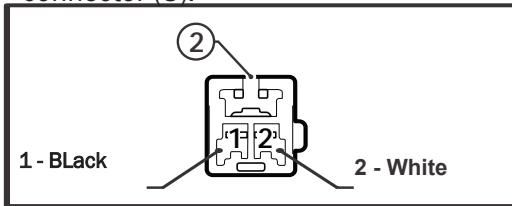

Rear view of 2-way connector

Check the wiring harness and vehicle patch harness are securely attached to the main vehicle harnesses.

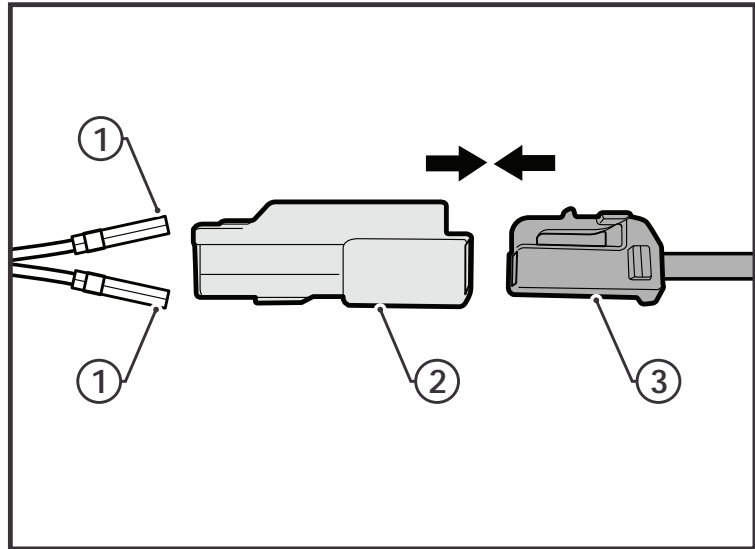

— STEP 14 —

Connect X-PATCH loom to CL-LOOM-LONG

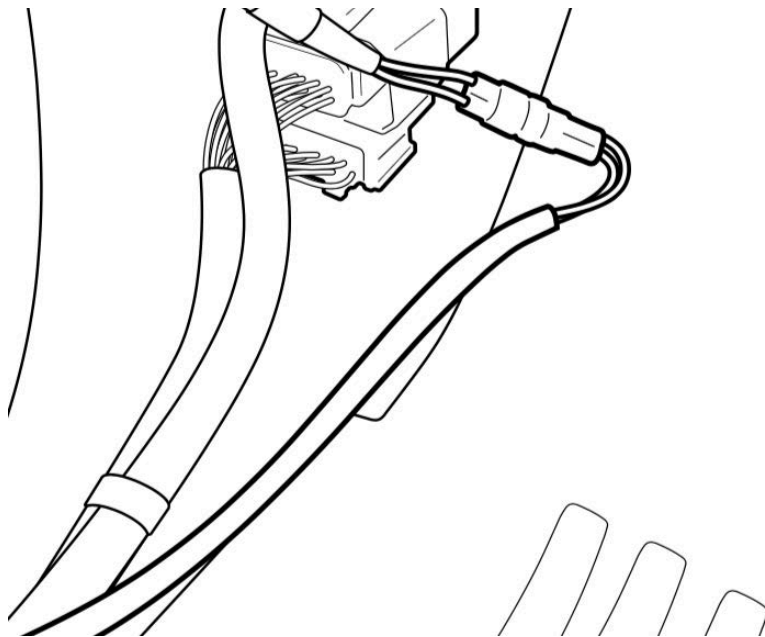

— STEP 15 —

Place and fasten tail gate cover.

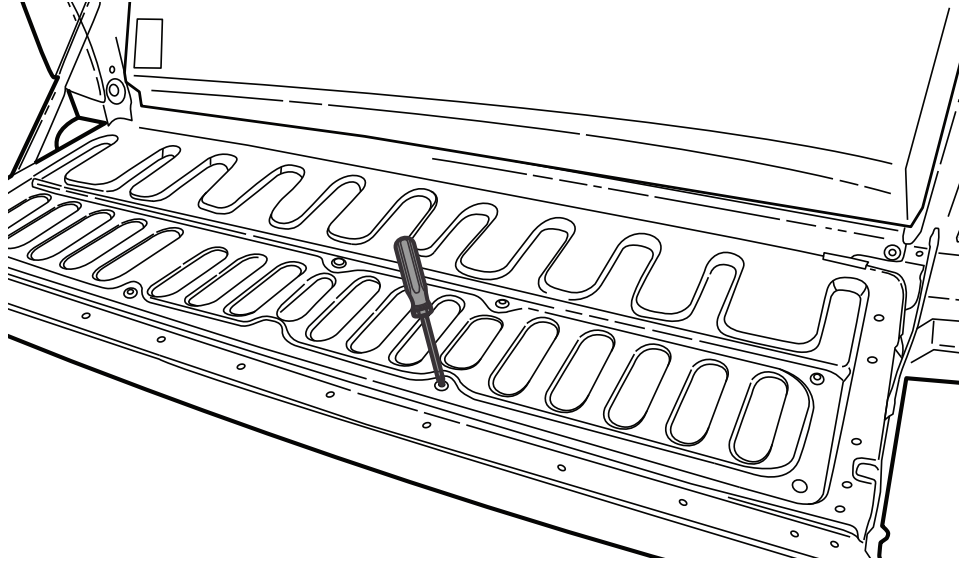

— FITTING COMPLETE —