

INSTALLATION / MAINTENANCE & Trouble Shooting Manual



INDEX

Component Identification	3
Important Notes / Warranty	3
Introduction	4
Maintenance	4
Installing Electron Generator	5 - 7
Selecting Electro - Coupler Number and Position	8 - 21
Running the coupler power supply line & attaching couplers	22 - 25
Testing the system output voltage	26
Trouble Shooting	27 - 29

IMPORTANT NOTES

This Electronic Rust Prevention System is covered by a ten (10) year Warranty. "Conditions Apply".

Please read the warranty conditions contained in the box in full, before commencing installation.

Although the system is relatively easy to install. Installation must be carried out in strict adherence to the Installation Instruction Manual, using all of the components supplied in the kit.

If the system detects a problem or component failure, it is designed to shut down, immediately ceasing all protection. Therefore the system must be inspected regularly. ie: the red LED light on the generator must be on continuously.

ERPS Component Identification

» Electron Generator



» Electro Coupler

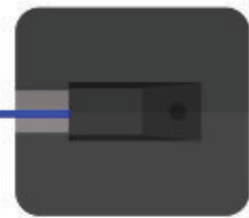

» Fuse



» T - Joiner



» Straight Joiner



> INTRODUCTION

The ERPS electronic rust prevention system is made up of an “Electron Generator” and a series of Electro-Couplers which are joined to a “Loop Circuit”, coupler power supply line.

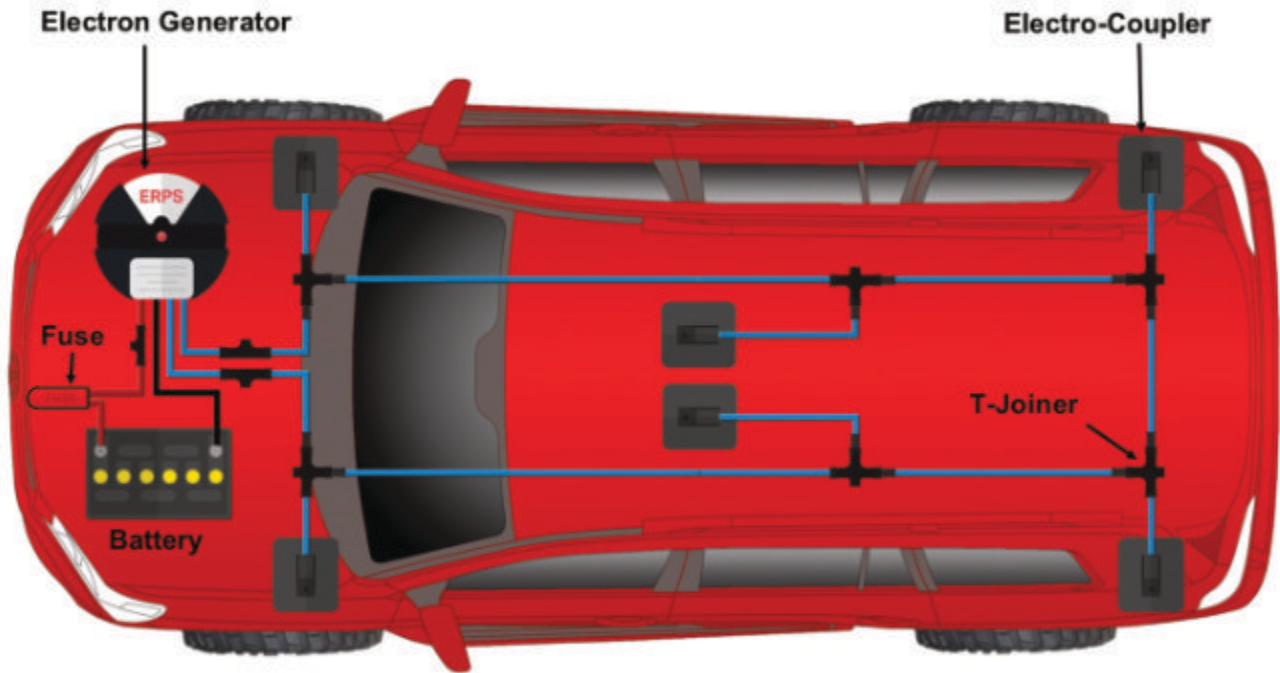

Typical ERPS System Layout

> MAINTENANCE:

The system is constructed of solid state electronics with no moving, wearing or sacrificial components. The system therefore requires no maintenance other than monthly inspection of the red LED indicator light incorporated in the Electron Generator. The red LED light should be constantly “on” (illuminated).

If the red LED indicator light is not continuously illuminated it means that a problem exists within the circuit.

The main causes of system failure are:

- » Blown fuse or poor quality battery connection.
- » Failed power generator.
- » Short circuit in a coupler, wire joint or the coupler supply line.
- » Broken wire.

For “Trouble Shooting” information see page 27-29 of this manual.



➤ INSTALLING THE ELECTRON GENERATOR



Step.1

Select a flat site as close as practical to the vehicle battery to fit the generator.

Ensure the generator is as far as practical away from heat sources such as the exhaust, or turbo charger.

Always attach the generator to the "Main" cranking battery, do not connect to auxiliary batteries. Using the supplied medi swab clean the fitting area thoroughly.

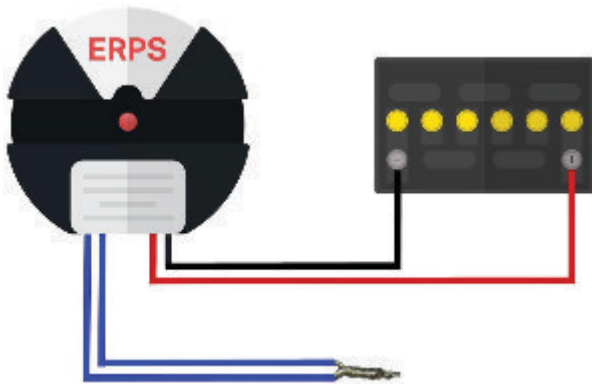

Step. 2

Before installing the generator, test its operation by twisting the two blue wires of the generator together. Temporarily hold the red and the black wires onto the battery. Firstly the black wire to earth (negative) terminal then the red wire to the positive terminal.

The red LED light on the generator should now illuminate, indicating that the generator is operating correctly. Be careful not to touch the blue wires with your fingers during testing as this may short out the generator and put out the light.



Step. 3

Peel the protective strip from the adhesive backing on the rear of the generator.

Place the generator into position and press down firmly for ten seconds.

➤ INSTALLATION PART. 1



Step. 4

Now run the red and black wires permanently to the battery and cut to length.

Use split tubing to protect the wires. Use 7mm inside diameter Nava Part no. 56709.



Step. 5

Solder the ring terminal to the negative (black) cable and connect to the negative terminal of the battery.

Do not remove the existing wires or cables from the battery. Undo the nut while holding all wires firmly in place, slip ring terminal onto battery bolt and re-tighten nut.



Step. 6

Connect the fuse to the positive (red) wire using the "straight joiner", but **do not** connect to the battery until the final stage of installation.

➤ INSTALLATION PART. 1



Step. 7

Connect the fuse by removing the tapered plug from the straight joiner and pushing the wires through.

Strip the insulation and twist the wires together.

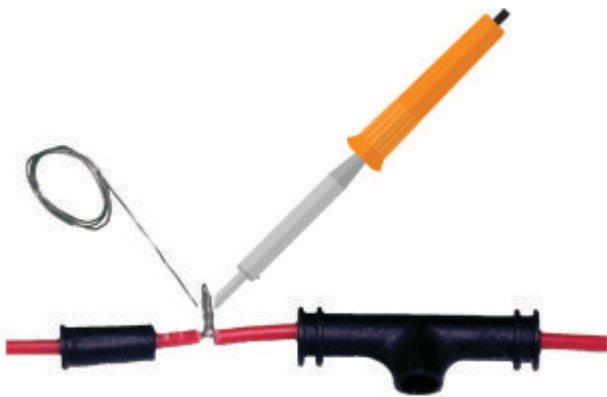

Step. 8

Solder the joint, trim any excess, then pull the joint back inside the straight joiner. Re-install the tapered plug.



Step. 9

NB: Ensure the joint is positioned centrally inside the straight joiner.

Now inject the straight joiner with silicon through the hole in the top until silicon can be seen squeezing out around the wires.

SELECTING ELECTRO COUPLER NUMBERS AND POSITION

Selecting the number of couplers and the position of the couplers is dependent on a number of different factors.

- » Vehicle Age
- » Vehicle Size
- » Current vehicle condition
- » The environment the vehicle will be subjected to

The systems strength is directly proportional to the number of couplers used. Much like a sprinkler system on a lawn - the more sprinklers used the greater the coverage and the coverage will always be greatest close to the sprinkler.

The principal is the same with the electrical charge from Electro Coupler. The charge will be strongest close to the coupler and the more couplers used, the stronger the overall charge and the better the distribution.

ERPS kits come in five standard sizes:

- » 2 Coupler
- » 4 Coupler
- » 6 Coupler
- » 8 Coupler
- » 10 Coupler

The diagrams on the following pages represent some typical vehicle coupler layouts.

Choose the diagram that best matches your vehicle and environmental application.

The standard ERPS generator is designed to supply up to twenty couplers within the loop circuit. This means couplers can be added at any time to boost the operation of the system.

Additional couplers, and coupler power supply line can be purchased separately as spare parts if required.

Additional Couplers:

part number ECU 300 (supplied with the T joiner & mediswab)

Additional Cable:

part number CWB 020 (20 metre roll)

CWB 030 (30 metre roll)

NB: It is important to use the genuine Cable supplied as it is not standard automotive cable. The cable supplied has tinned copper wiring and is insulated to a much higher value to withstand the high voltage of the ERPS system.

Index of Coupler Selection Diagrams

VEHICLE	PAGE
Car	10
Classic Car	11
2WD Single Cab Alloy Tray	12
2WD Single Cab Steel Tray	13
2WD Dual Cab Alloy Tray	14
2WD Dual Cab Steel Tray	15
4WD Wagon Under 2 Ltr	16
4WD Wagon Over 2 Ltr	17
4WD Single Cab Alloy Tray	18
4WD Single Cab Steel Tray	19
4WD Dual Cab Alloy Tray	20
4WD Dual Cab Steel Tray	21



> Low Corrosion Environment - 2 Couplers

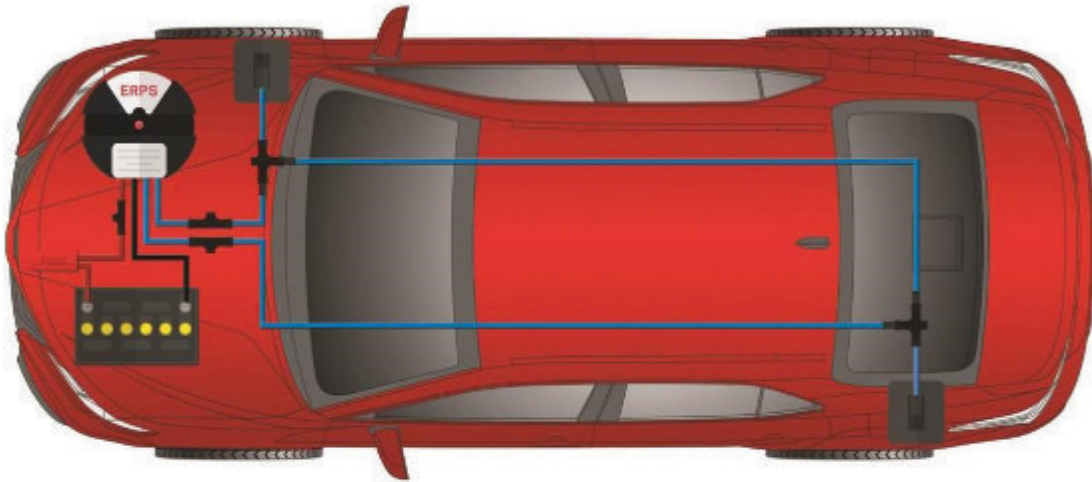

> High Corrosion Environment - 4 Couplers

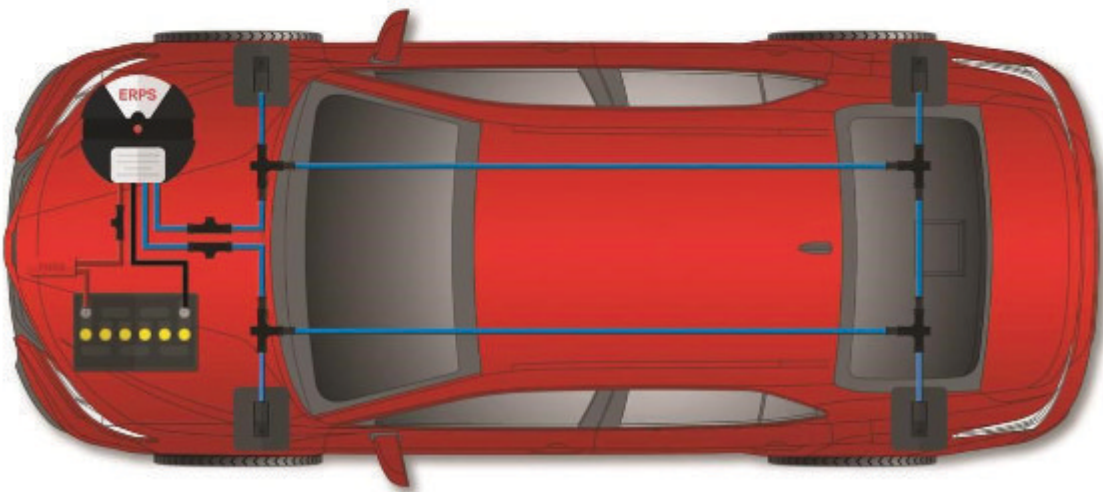

> CLASSIC CARS



> Low Corrosion Environment - 4 Couplers

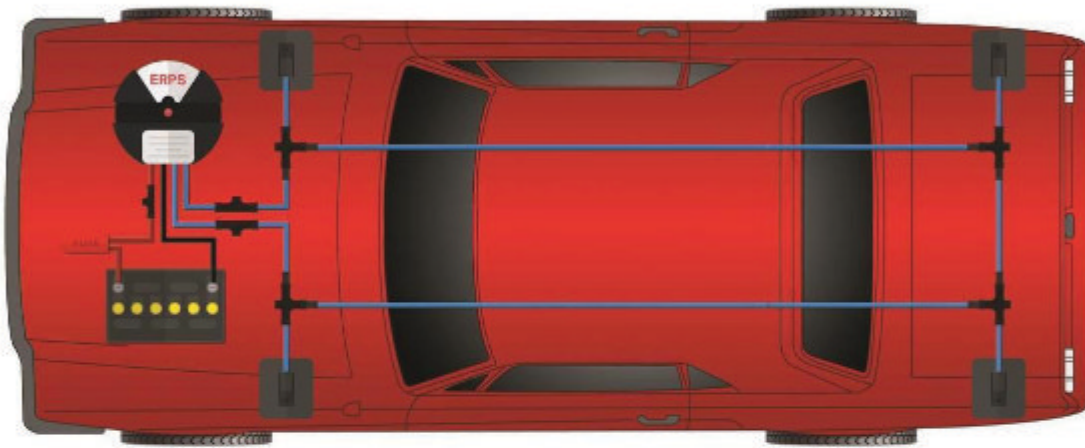

> High Corrosion Environment - 6 Couplers

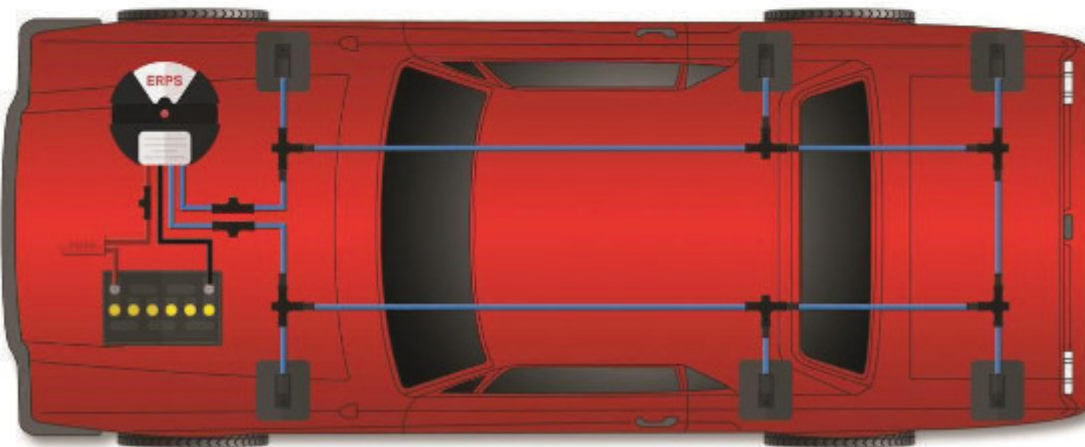

> 2WD - SINGLE CAB - ALLOY TRAY



> Low Corrosion Environment - 2 Couplers

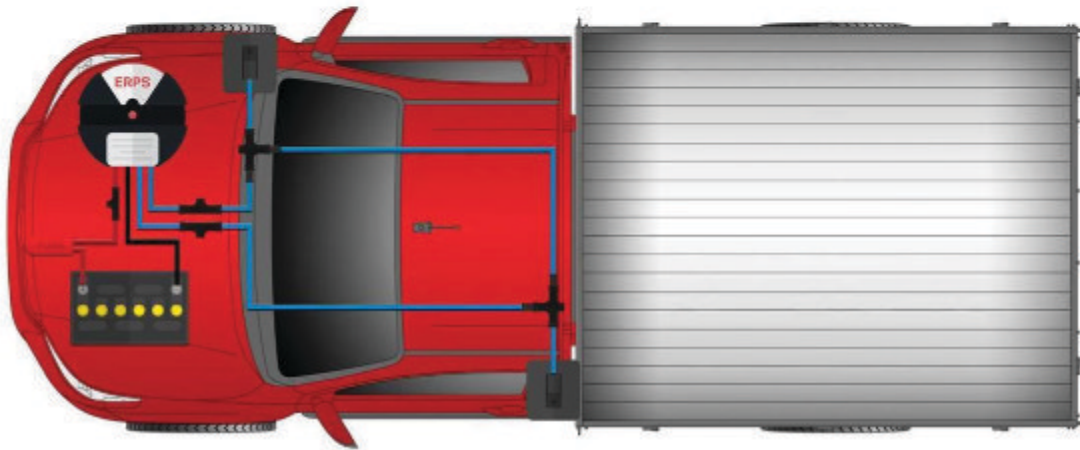

> High Corrosion Environment - 6 Couplers

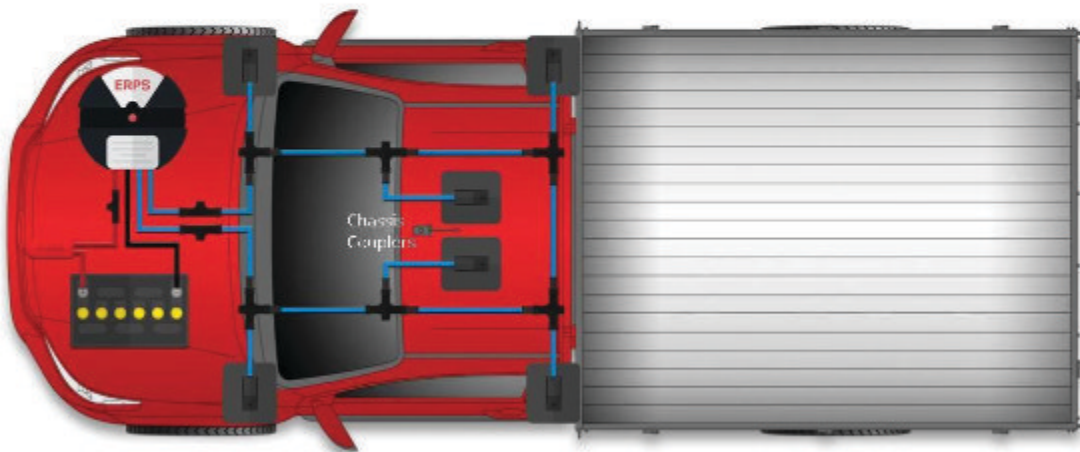

> 2WD - SINGLE CAB - STEEL TRAY

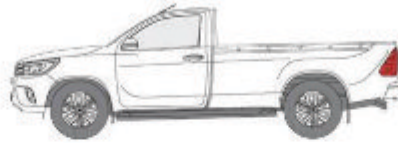

> Low Corrosion Environment - 4 Couplers

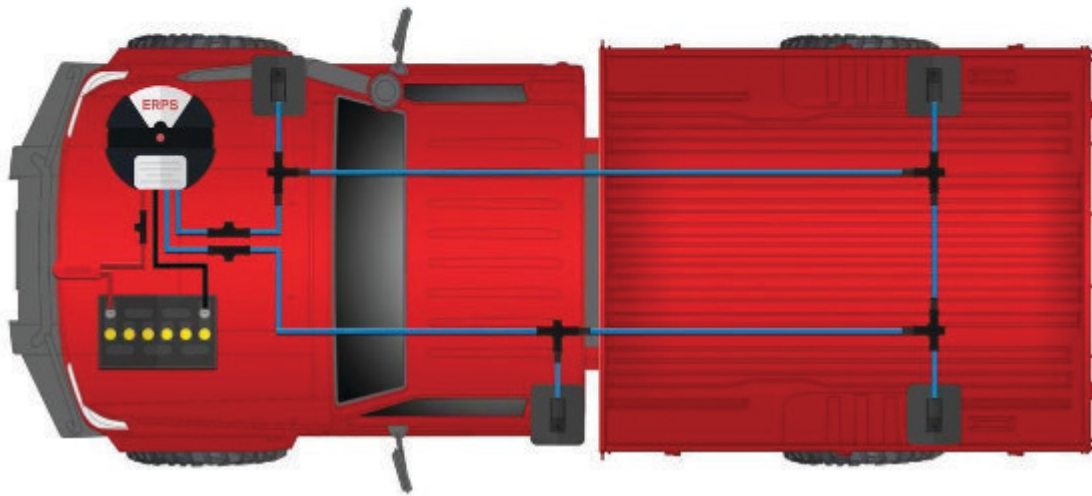

> High Corrosion Environment - 8 Couplers

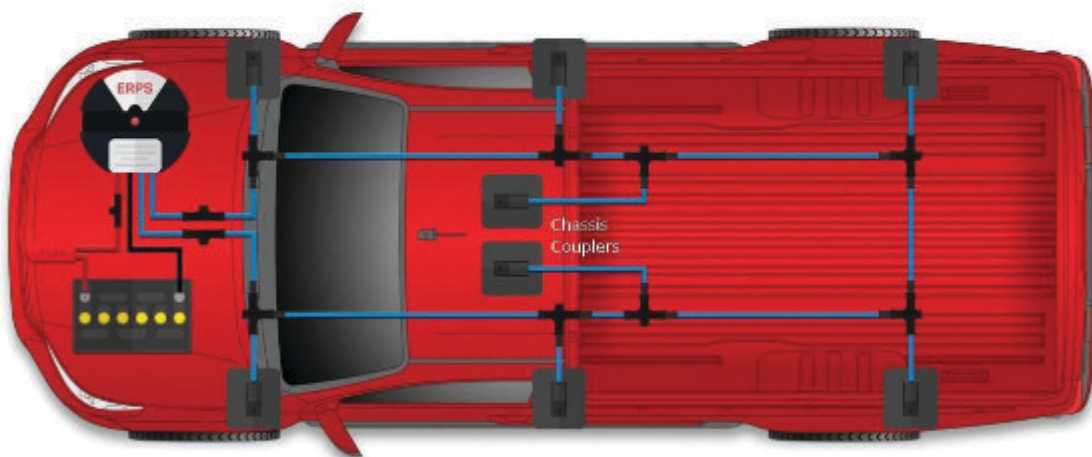

> 2WD - DUAL CAB - ALLOY TRAY



> Low Corrosion Environment - 2 Couplers

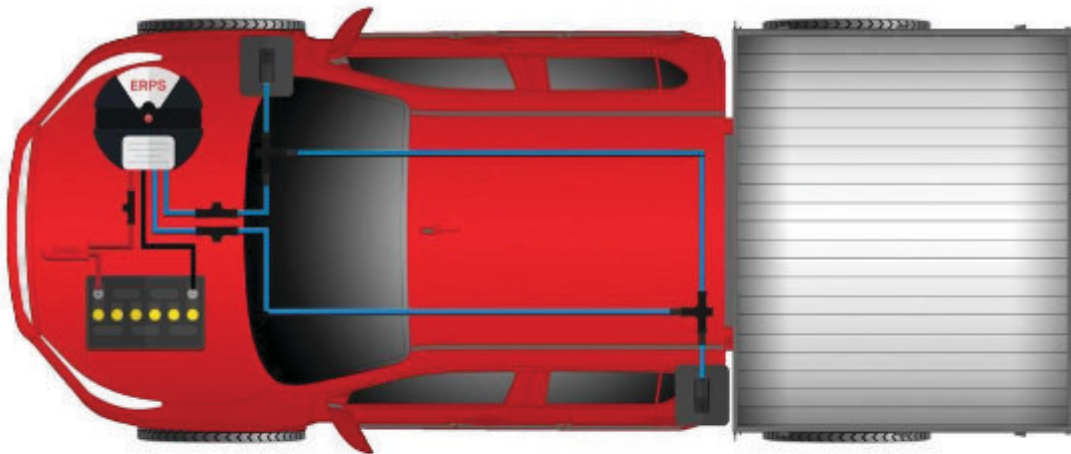

> High Corrosion Environment - 6 Couplers

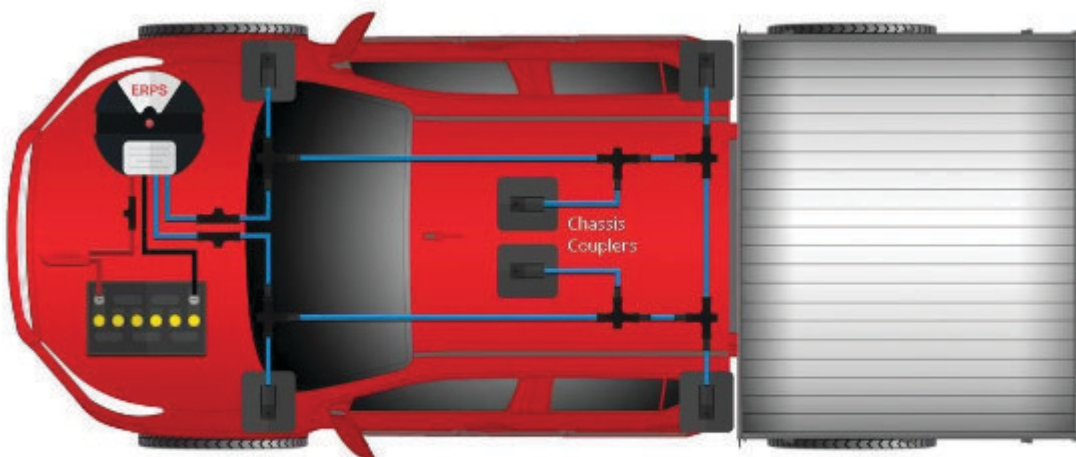

> 2WD - DUAL CAB - STEEL TRAY



> Low Corrosion Environment - 4 Couplers

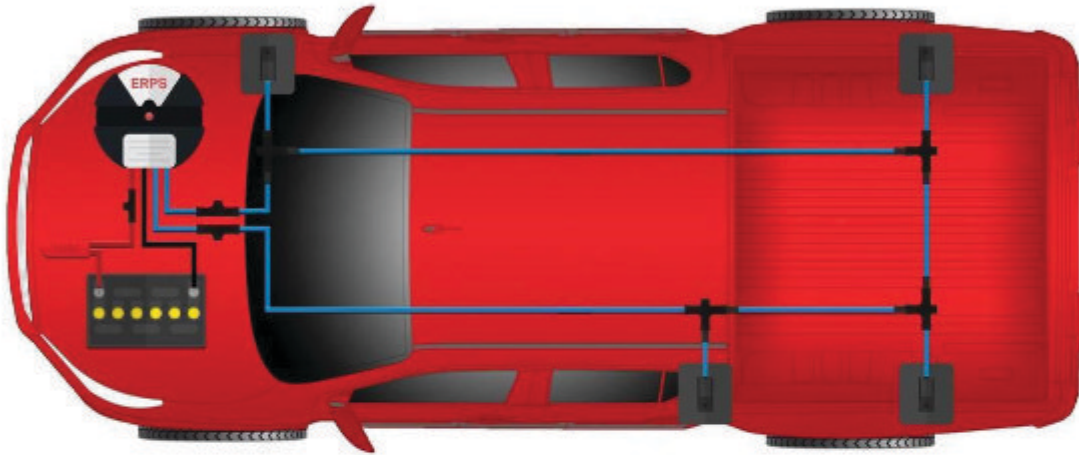

> High Corrosion Environment - 8 Couplers

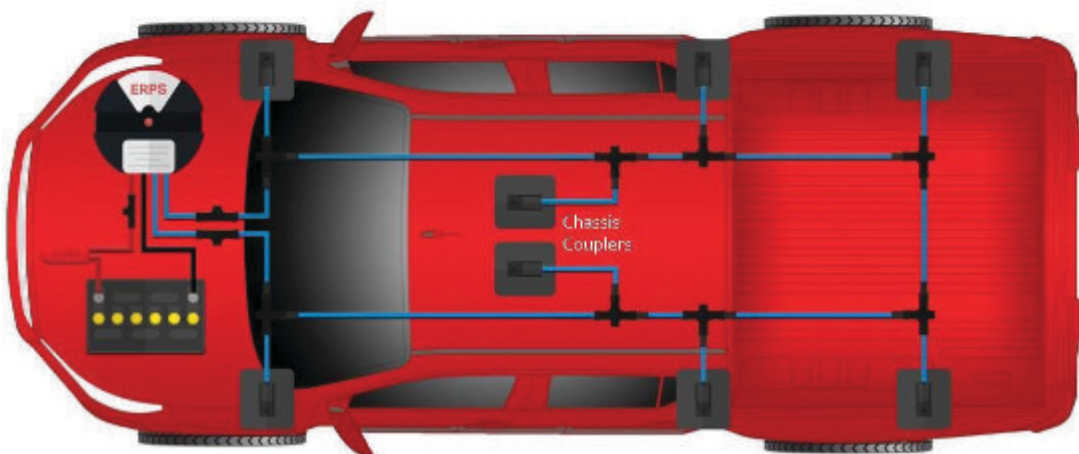

> 4WD - WAGON - UNDER 2 Ltr



> Low Corrosion Environment - 4 Couplers

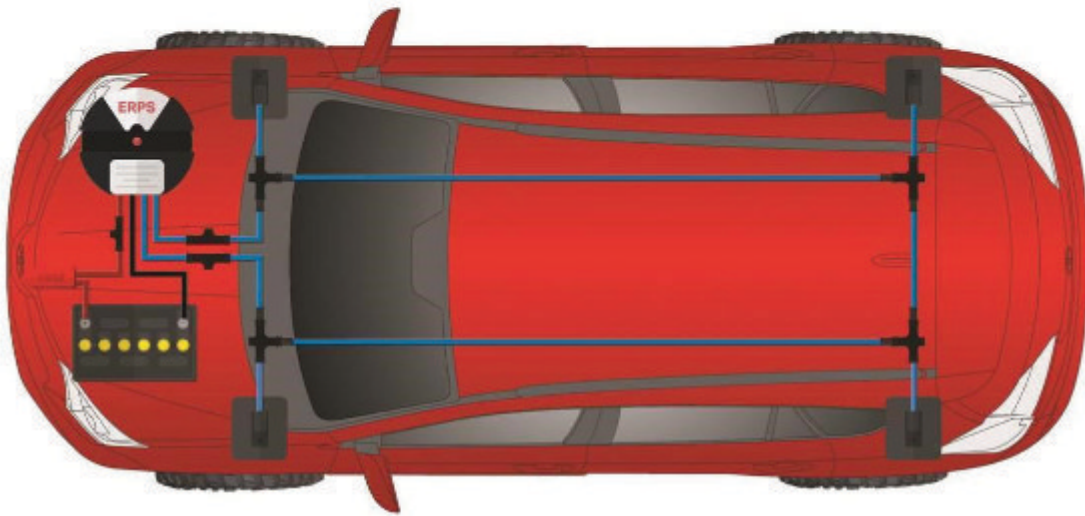

> High Corrosion Environment - 6 Couplers

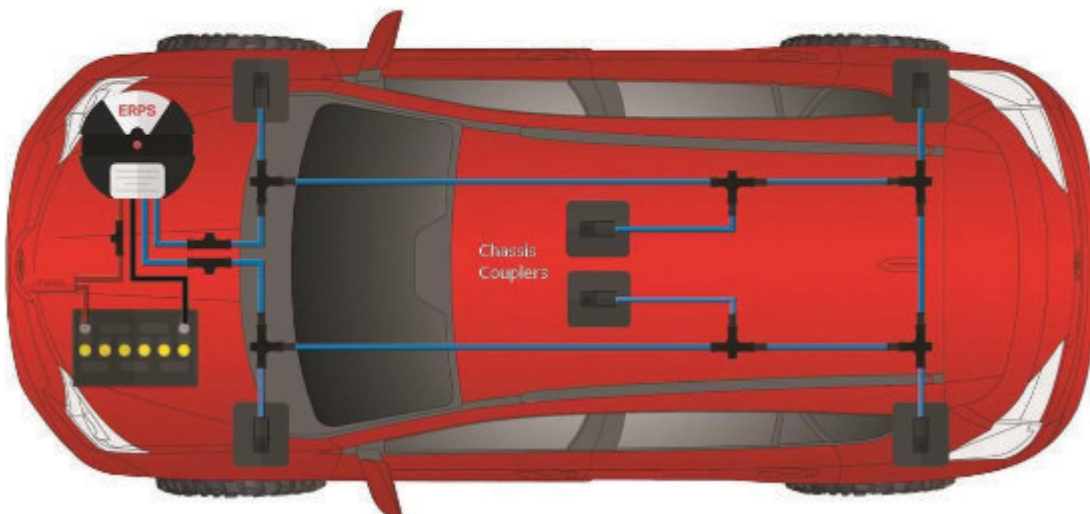

> 4WD - WAGON - OVER 2 Ltr



> Low Corrosion Environment - 6 Couplers

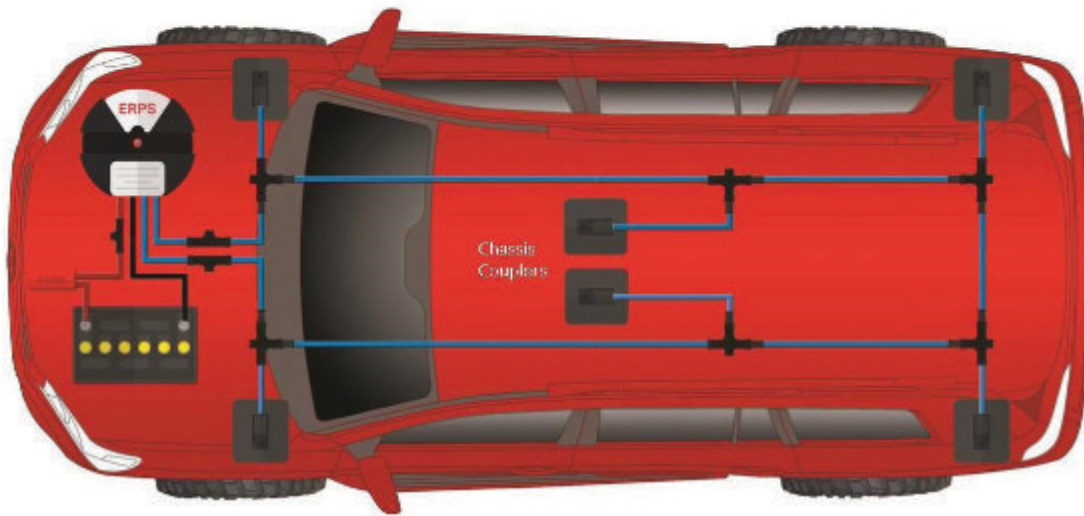

> High Corrosion Environment - 8 Couplers

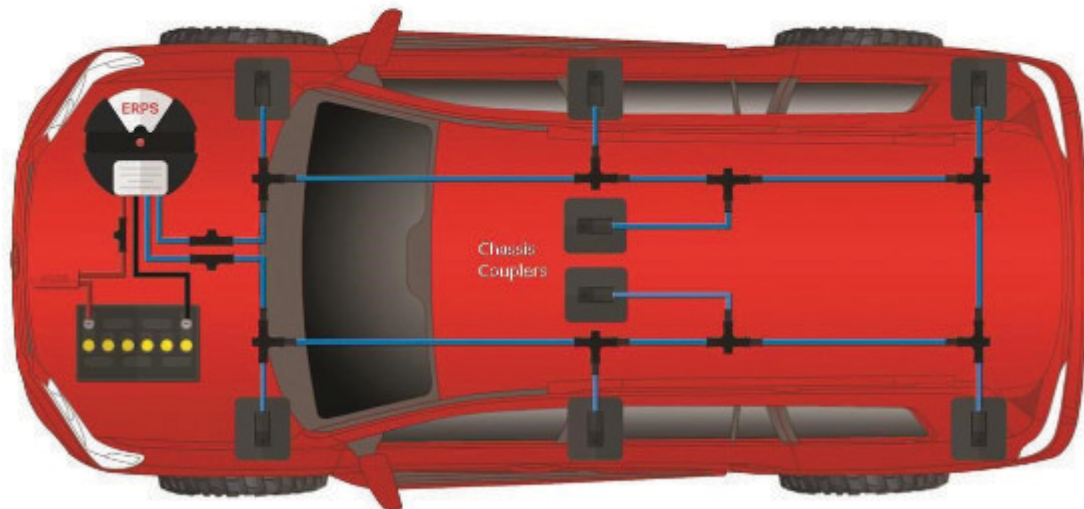

> 4WD - SINGLE CAB - ALLOY TRAY



> Low Corrosion Environment - 4 Couplers

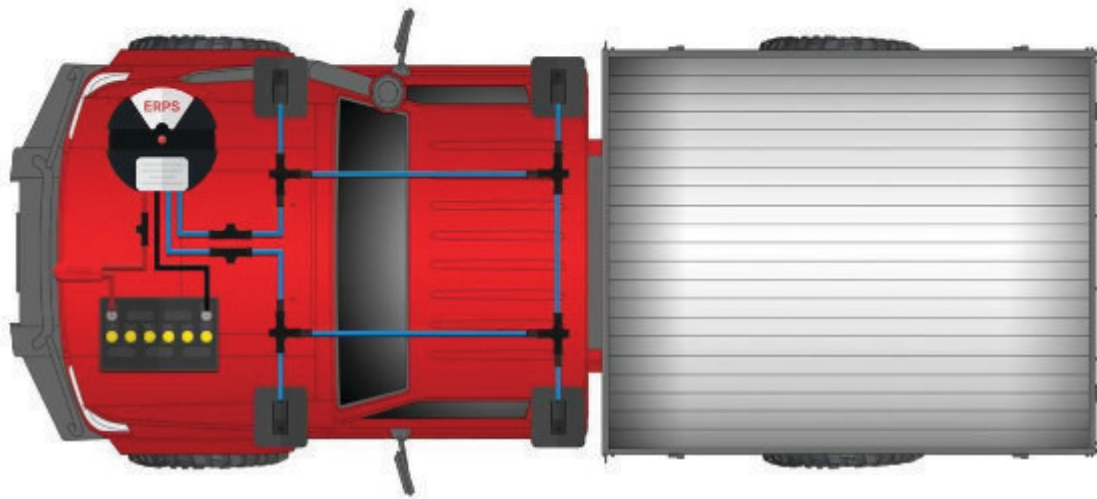

> High Corrosion Environment - 6 Couplers

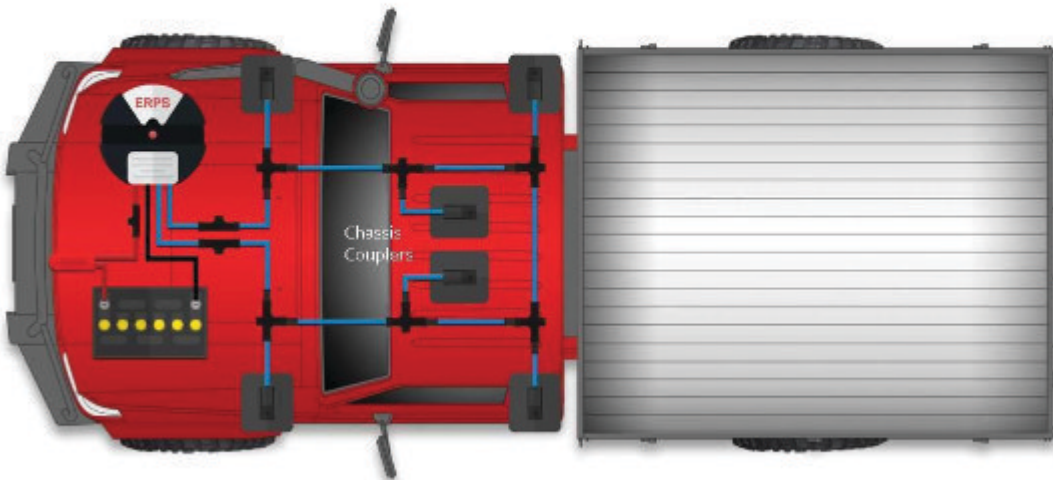

> 4WD - SINGLE CAB - STEEL TRAY



> Low Corrosion Environment - 6 Couplers

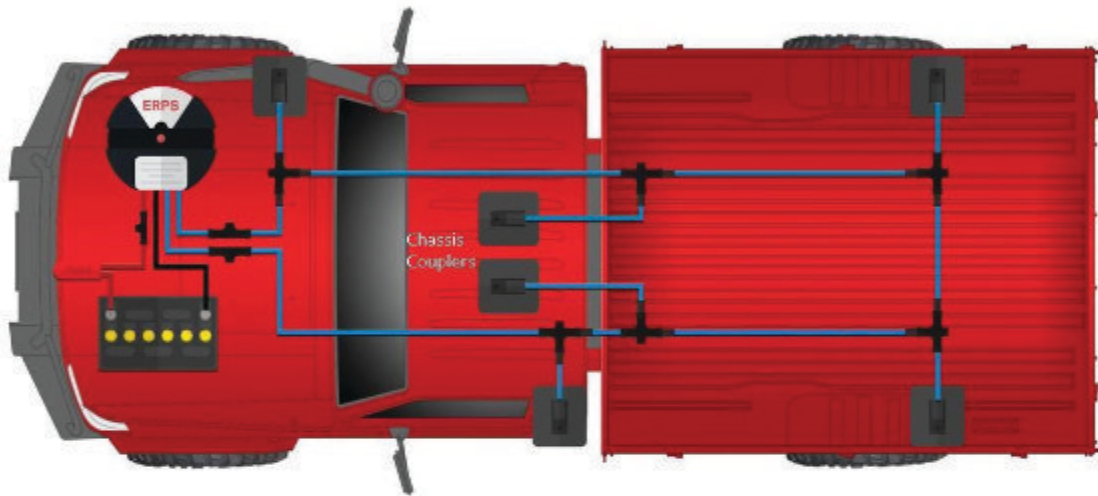

> High Corrosion Environment - 8 Couplers

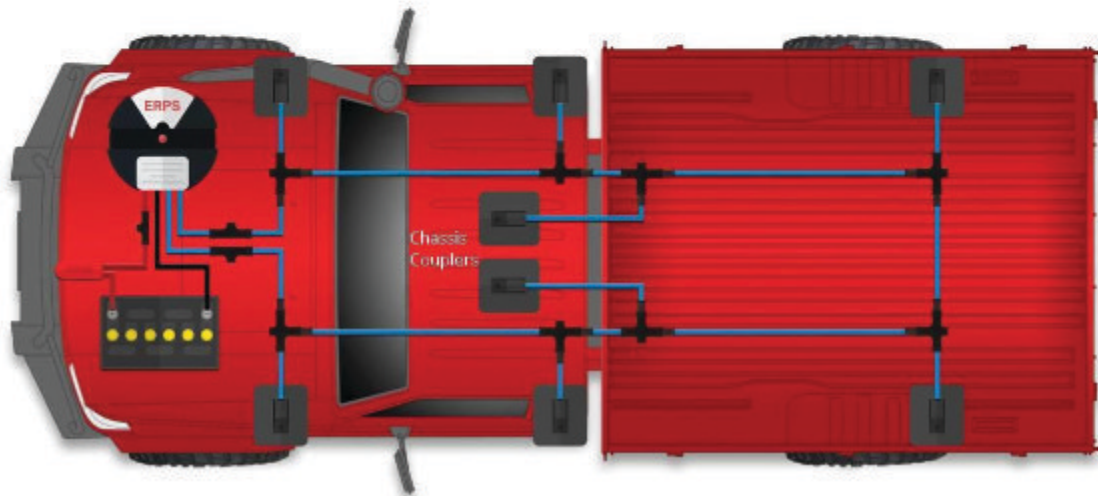

> 4WD - DUAL CAB - ALLOY TRAY



> Low Corrosion Environment - 6 Couplers

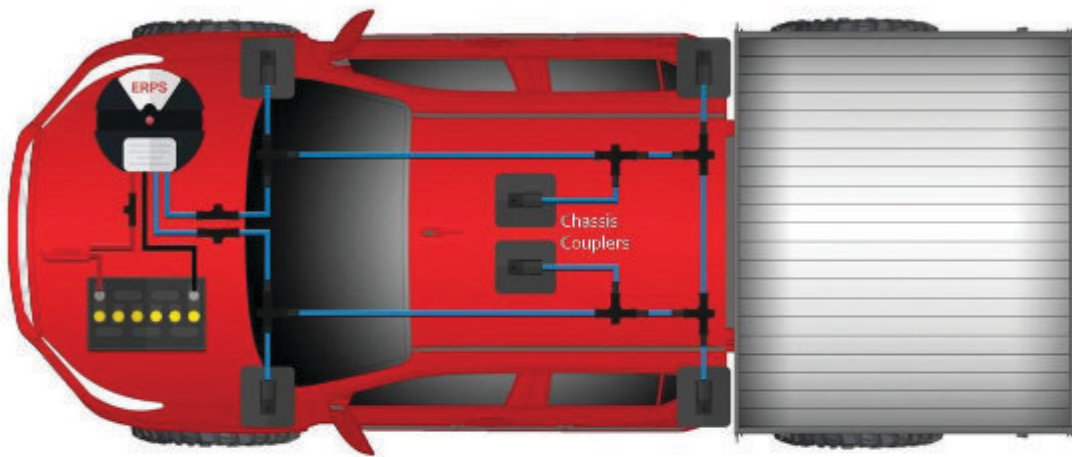

> High Corrosion Environment - 8 Couplers

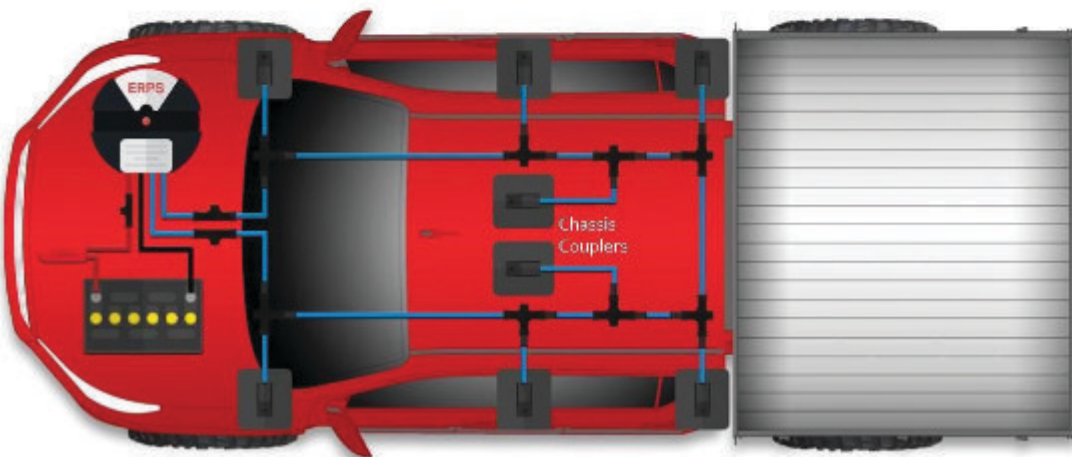

> 4WD - DUAL CAB - STEEL TRAY



> Low Corrosion Environment - 8 Couplers

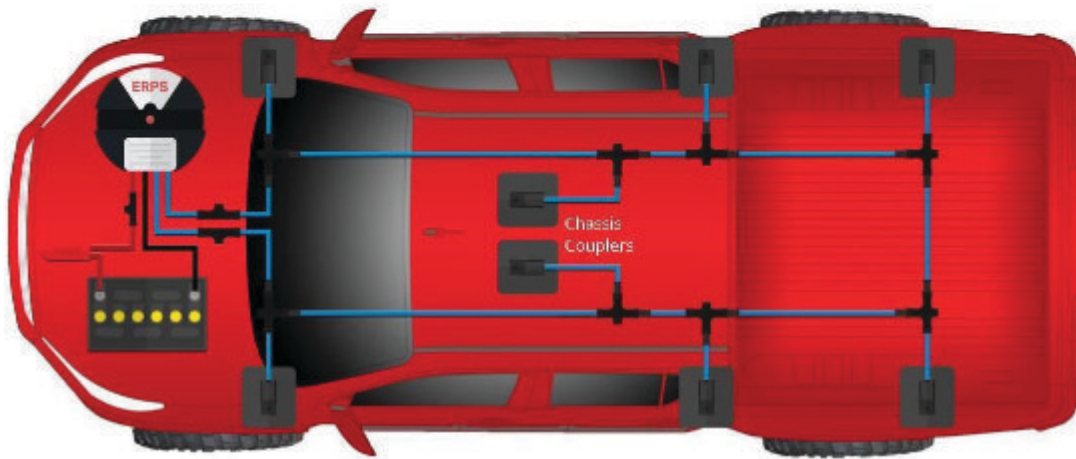

> High Corrosion Environment - 10 Couplers

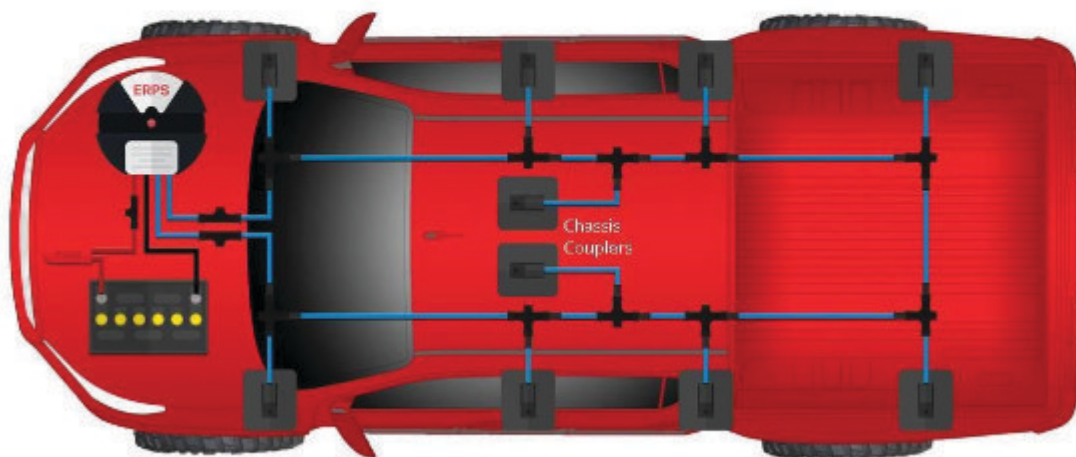

➤ INSTALLATION PART. 2 SELECTING ELECTRO COUPLER SITES



Step. 10 - Electro Coupler Sites must be:

- » Flat (no contoured surfaces)
- » Well painted
- » Free of indentations, holes or scratches.
- » As far as practical, away from excessive heat or moisture.
- » Free of bituminous paint, underseal or sound deadener.
- » Thoroughly cleaned



Step. 11 - Important Note:

The coupler site must be well painted. Most vehicles have sufficient paint in the engine compartment but not on internal panels or the rear compartments.

If in any doubt, apply two coats of Quick Dry Enamel (aerosol can) to the coupler site fifteen minutes apart while running the coupler power supply line. It is only necessary to coat about 150mm square.

If the paint at the coupler site is too thin the coupler can short through to the steel body and the system will shut down.

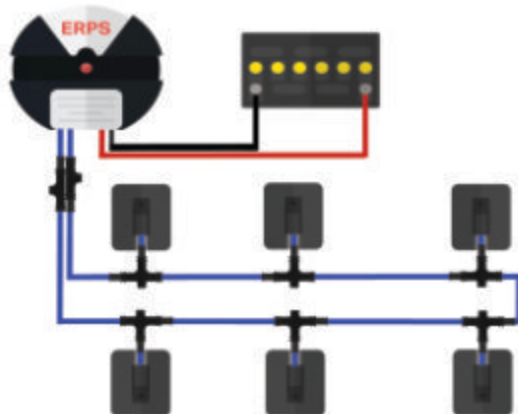

Step. 12 - Running the Electro-Coupler Power Supply Line

Join the coupler power supply wire (blue wire supplied on a roll) to one of the blue output wires from the generator using one of the straight wire joiners. Run this to the first coupler, attaching the couplers as detailed below.

After attaching the last coupler, return the coupler power supply wire to the second blue wire on the generator. The two blue wires on the generator are bi-directional and can be attached either way.



INSTALLATION PART. 3

ELECTRICAL CONNECTION OF ELECTRO COUPLERS

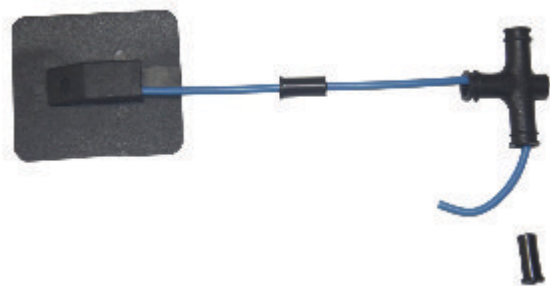

Step. 13

Remove both tapered plastic plugs from the T joiner. Push one plastic plug onto the coupler wire (ensure the small end of the taper faces the T joiner). Then twist the end of the wire in an arc, this will help to feed the wire through the T joiner.

Push the wire through the bottom port of the T joiner and out of the top port where you removed the tapered plug.

NB: Do NOT strip the insulation from the wire at this stage as it makes it harder to feed through the T joiner.

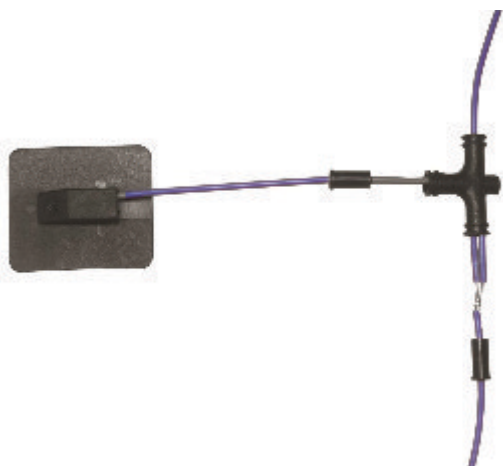

Step. 14

Push one cable of the coupler power supply line through the top port of the T joiner and rejoin it to the coupler power supply line and the coupler wire.

NB: Ensure you have attached all plastic tapered plugs before soldering the joint.



Step. 15

Solder the wire joint then pull it back inside the plastic T joiner.

Push all tapered plugs back into the T joiner.

➤ INSTALLATION PART. 3



Step. 16

Inject the plastic T joiner with silicon through its top port until silicon starts to ooze out around the wires.

NB: Do not fill the T joiner of the coupler closest to the generator until after you have tested the system voltage.



Step. 17

Wherever possible both the couplers and the coupler wiring should be run **INSIDE** the vehicle to minimise the chance of damage to the system.

If it is necessary to attach couplers externally (on the chassis for example), ensure the wire is protected with split tubing and the coupler is positioned to avoid damage.

Always use rubber grommets when running wires through firewall or other bulkheads.



Step. 18

The split tubing slips over the ribs of the T Joiner and locks into place.

Fastened with a cable tie.

CONTINUE JOINING EACH COUPLER IN A LOOP CIRCUIT AROUND THE VEHICLE.

After returning to the generator, connect the coupler power supply line to the remaining blue wire of the generator to complete the "Loop Circuit".

NB: The generators blue power supply lines are by directional and can be connected to either wire from the couplers.

COUPLER POWER SUPPLY LINES MUST BE:

- » Run inside the vehicle wherever possible.
- » Protected with split tubing when inside the engine bay, outside of the passenger compartment or any position that they may incur damage.
- » Tied firmly with cable ties. Existing brake or electrical lines can be used to brace the line.
- » Protected by rubber grommets when travelling through the firewall or similar bulkhead.
- » Run in areas where they will not be damaged by impact or excessive wear.



INSTALLATION PART. 4

ATTACHING THE ELECTRO COUPLERS TO THE VEHICLE



Step. 19

Having selected the coupler sites, thoroughly clean an area (about 150mm square) with the medi-swab supplied, and allow to dry.

If the site is very dirty or undersealed, use white spirits or similar and a rag to clean the area.

Always finish with the medi-swab.



Step. 20

Peel off the paper cover (do not touch the adhesive face)

Firmly press the coupler onto the prepared site.

NB: Couplers must be attached to a well painted surface. Do not remove the paint or attach a coupler to a surface with insufficient paint. This will cause the coupler to short and shut down the system.



Step. 21 - Important

Finally apply silicone around the edge of the coupler. The silicone application must seal the coupler to the painted surface.

Any infiltration of salt air or moisture to the coupler / paint surface interface will cause coupler failure, in turn causing the system to shut down.

Use normal roofing and guttering silicone, make sure it is marked "neutral cure" (acid free).

➤ INSTALLATION PART. 5 CONNECTING THE ELECTRON GENERATOR



Step. 22

Connect the Red wire (from the fuse) to the positive terminal on the battery.

Again, do not remove existing wires or cables from battery.

Undo nut while holding wires firmly in place, slip ring terminal onto battery bolt and retighten nut.

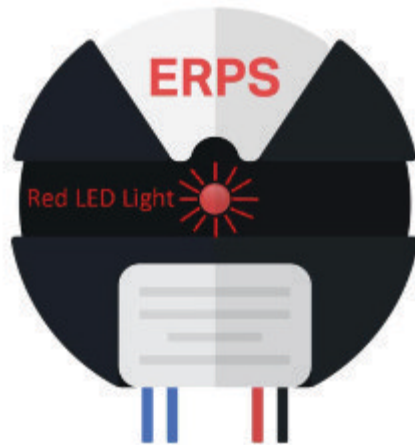

Step. 23

The generator red light should come on confirming the system is operating correctly.

The red light should remain on at all times to show that the system is working.

Be sure that the generator is connected to the correct power supply (12V) to safeguard the system and maintain warranty.

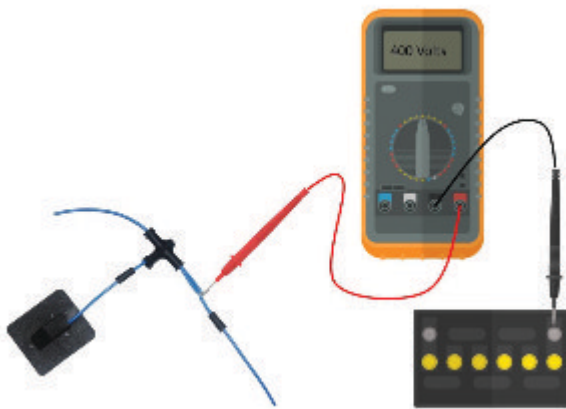

Step. 24

Testing the coupler supply line voltage. Using a good quality multimeter (minimum 10 Mega ohm internal resistance) check the voltage between the blue power supply line (at the joint closest to the generator) and ground (battery negative terminal). Voltage should be a minimum of 400 volts DC, when the vehicle is running.

NB: Be careful not to touch the live wires with your fingers, this will short the system and give you a false reading. If the Red LED light goes out when the multimeter is connected or you record a low voltage reading - you may have an issue with the multimeter you are using. Try another meter.

Now seal the joint with silicone. If you do not achieve 400 volts, follow the trouble shooting guide.

> TROUBLE SHOOTING GUIDE



Be sure that the Electron Generator is connected to the correct power supply to safeguard the system and maintain warranty. All generators are 12 volts DC unless otherwise marked on the casing.

The Generators red LED indicator light should be illuminated at all times, indicating that the system is operating correctly.

If the red light is "NOT ON" follow the steps below.

Check that the battery connections (red & black wires) are tight. Check that the fuse has not blown. If the fuse has blown a LED light should glow in the end of the fuse.

Cut the two blue wires approximately 200mm from the generator, this isolates the generator from the coupler power supply line. Bare the wires and twist them together. Check the red LED indicator light on the generator is on or check the voltage with a multimeter as per diagram below. The voltage should be a minimum of 400 volts DC with the vehicle engine running.

NB: do not touch the blue wires while checking the light or voltage reading as your body may short the wires to ground giving a false reading.

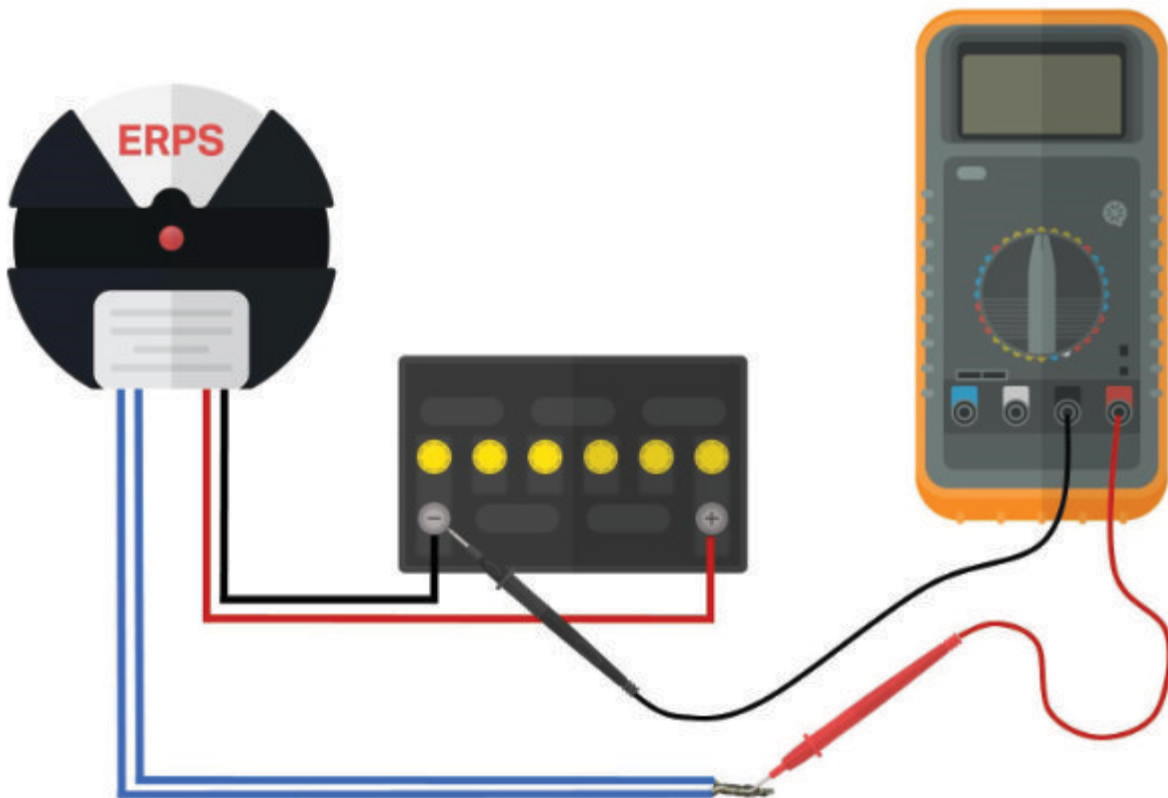

> TESTING HALF OF THE CIRCUIT FOR FAULTS - STEP. 1

Scenario 1 Red LED indicator light **“DOES NOT”** come on.

The generator requires replacement. You can replace the generator with a new unit or return it to your point of purchase for testing.

Scenario 2 Red LED indicator light **“DOES”** come on.

If the light does come on this indicates that the generator is operating correctly and a fault has occurred in the coupler supply line.

Possible faults in the coupler supply line.

- » Broken wire
- » Short to ground in wiring (jammed wire, damaged insulation)
- » Short in one or more couplers

Step One:

To isolate where the fault is within the coupler power supply line, divide the coupler power supply line into two halves. This can be done by cutting the line and attaching a jumper lead from the break in the line back to the generator as in the diagram below. This completes the loop circuit in one half of the vehicle only.

Diagram 1

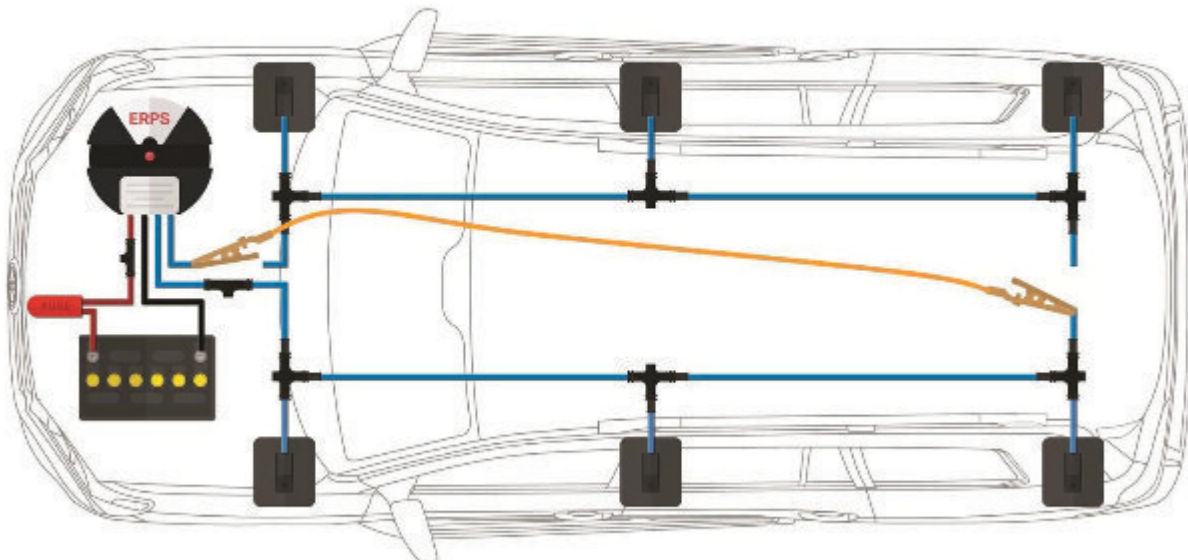

If the generator's LED indicator light comes on, this half of the circuit is ok. Proceed to "Step Two". If the light is not on, divide the system in half again until the fault is isolated.

➤ TESTING HALF OF THE CIRCUIT FOR FAULTS - STEP. 2

Step Two:

Connect the generator to the second half of the circuit as per diagram below.

Diagram 2

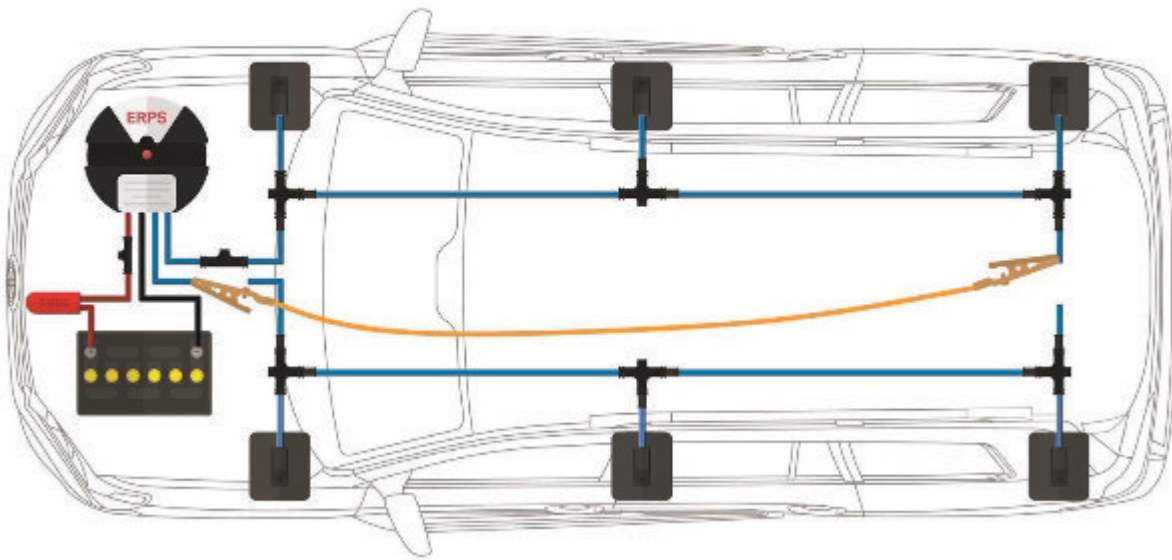

Again if the generator's LED indicator light comes on, this half of the circuit is ok. If the light is not on, divide the system in half again until the fault is isolated.

Electronic Rust Prevention Systems

PO Box 348, Currumbin Qld 4223 Australia Pty Ltd
Ph: +61 7 5534 3899 | email: contact@erps.com.au
ABN: 89 167 832 527 | Web: www.erps.com.au

II-06 – Installation Manual - Rev 20 revised 28/03/2019- Note: Check Document is still current before use.
© Copyright 2018 Electronic Rust Prevention Systems P/L All Rights Reserved

