



WWW.HSPUTELIDS.COM

1300 441 498

Part No: C18

Fitting Time: 45mins



HOLDEN COLORADO 2016+
(MY16)

HSP TAIL LOCK

FITTING INSTRUCTIONS

—GENERAL NOTES

- Read through the fitting instructions prior to installation of accessory.
- Ensure all recyclable components and packaging are discarded and recycled following local recycling regulations.
- Safely store and protect any removed vehicle components.

—SAFETY NOTES

- Check that all work practices comply with safety standards.
- Please wear appropriate clothing and use safety equipment.

—FITTING TIME



45mins

—PARTS SUPPLIED

Part Description	Part Number	Quality	Check list
TAIL LOCK ASSEMBLY			
Actuator Cam bracket	C18- A	1	
Rod	C18-B	1	
Cam bracket	C18-C	1	
Actuator	ACT-01	1	
Plastic Cam	ACT-01-CAM	1	
Wiring	CL -LONG-LOOM	1	
Patch	CL-PATCH	1	
FASTNERS			
Shoulder bolt	C18-D	1	
Star clip lock	41	2	
Nylon washer	C18-E	2	
Actuator screws	36	2	
OTHER			
Cable ties		5	
Fitting instructions		1	

—STEP 1—

1. Push Plastic striker on to the actuator till it clicks into position.
2. Load Rod into the actuator striker as shown.

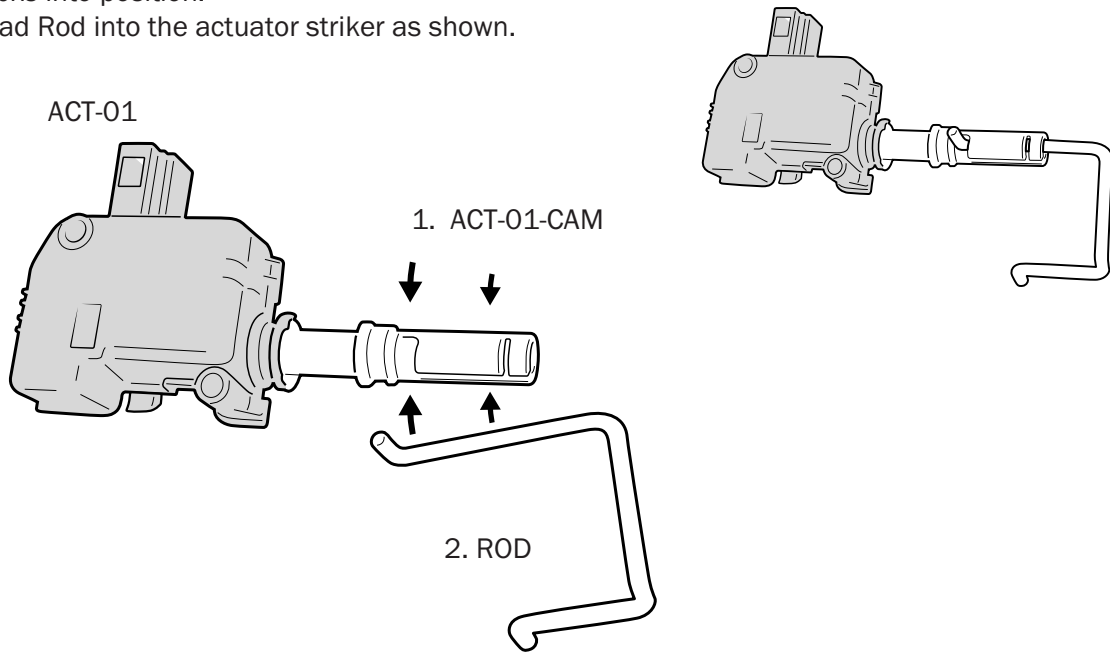

—STEP 2—

Load the star lock clip followed by the nylon washer as indicated.

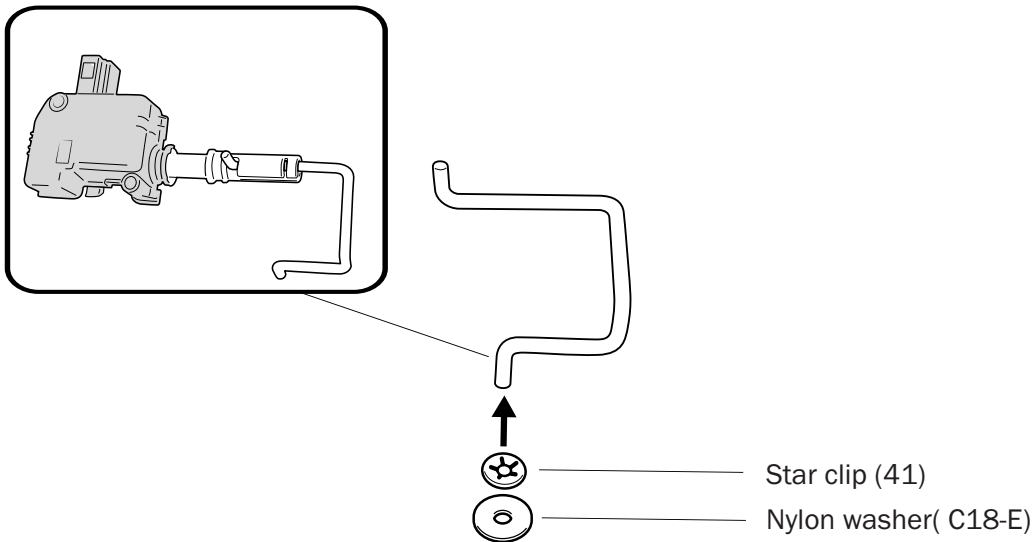

—STEP 3—

Load actuator on the Tail Lock bracket (C18-A) as shown, secure with screws provided part number (36).

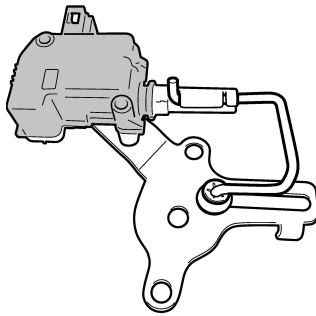
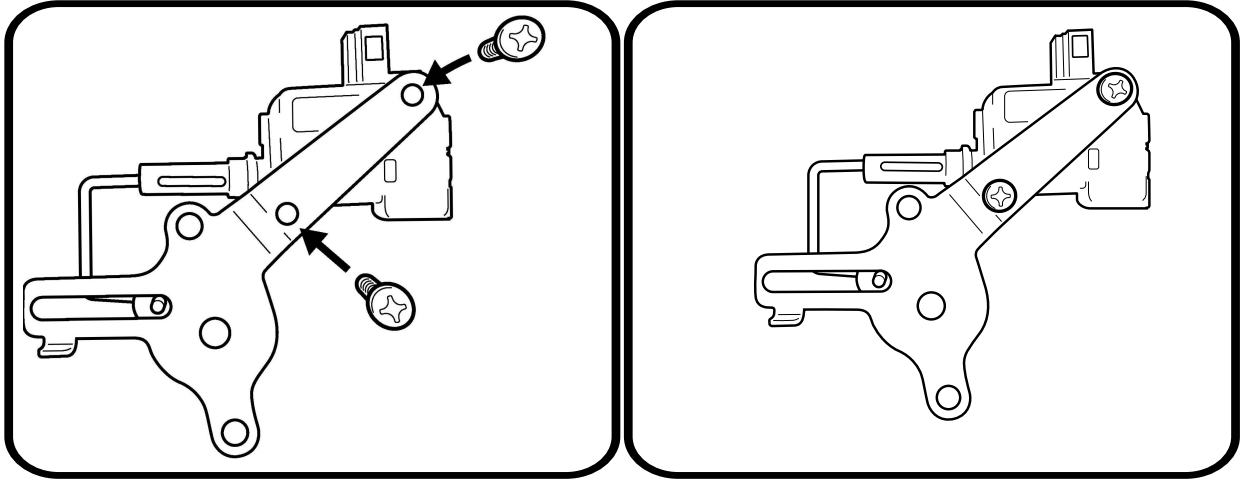

—STEP 4—

1. Place bracket C18-C on to bracket C18-A as indicated.
2. Place nylon washer as indicated and load the star clip lock washer to lock in place.

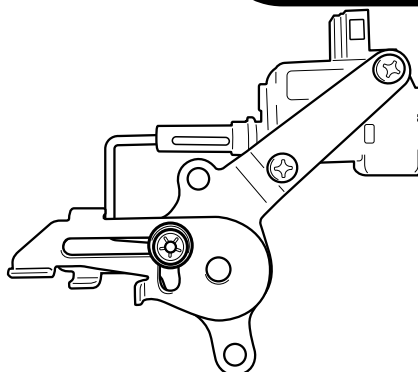
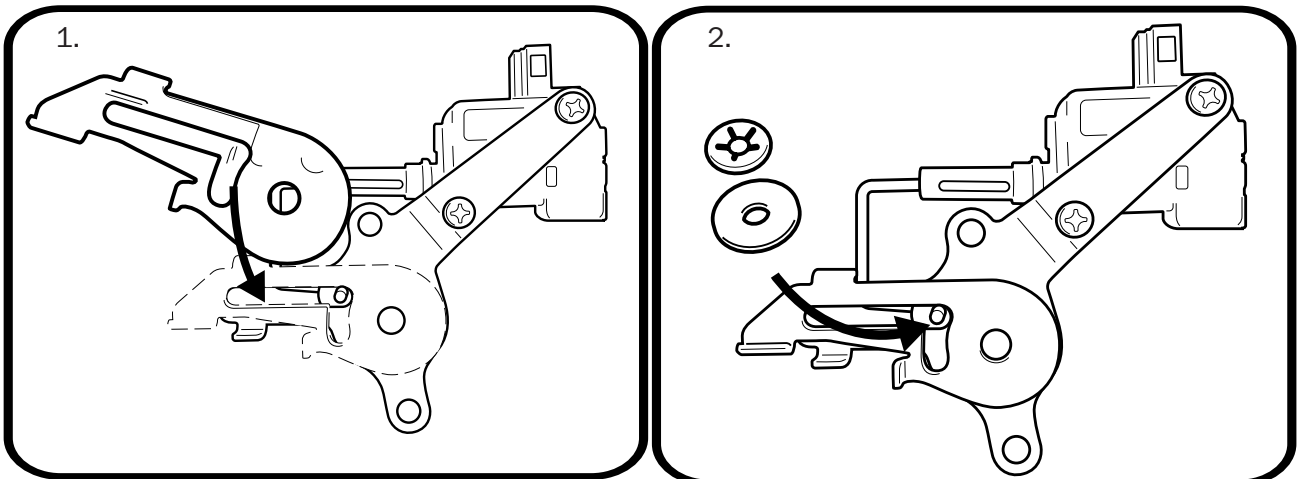

— STEP 5 —

Remove tail gate cover.

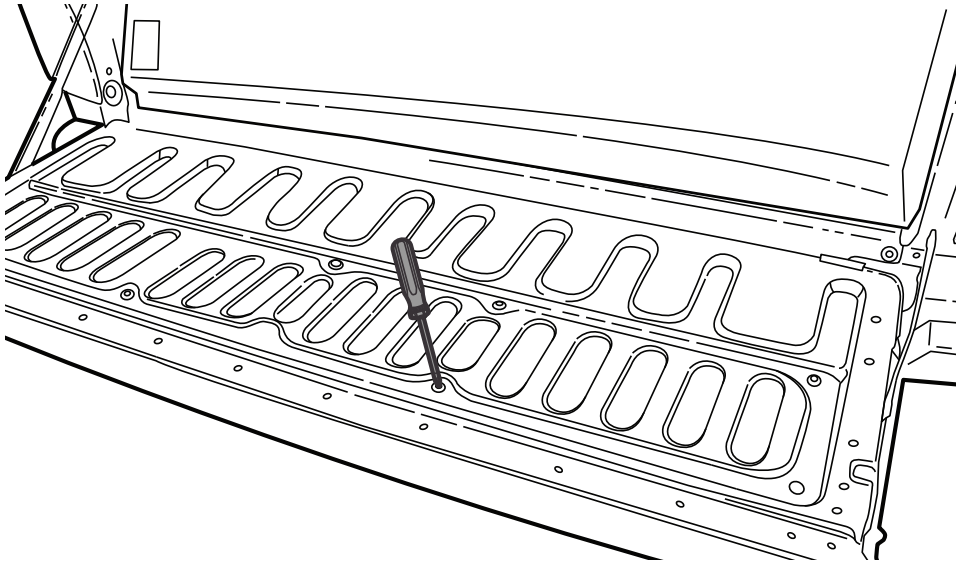

— STEP 6 —

Disconnect indicated rods shown.

Handles with no lock barrel

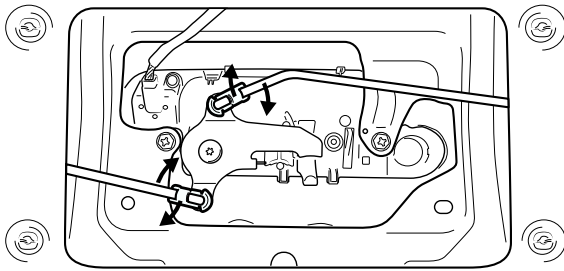

Handles with lock barrel

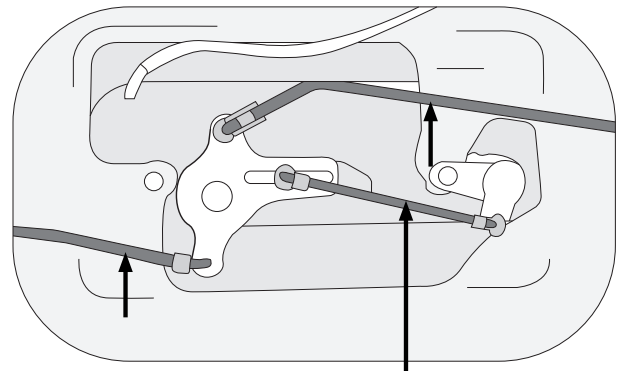

DISCARD THIS ROD

— STEP 7 —

1. Remove cam bracket. **Note:** Handles with lock barrels will also have a smaller cam bracket that needs removing.
Discard both the shoulder bolt and the cam bracket/brackets.
2. Remove and discard m6 washer.

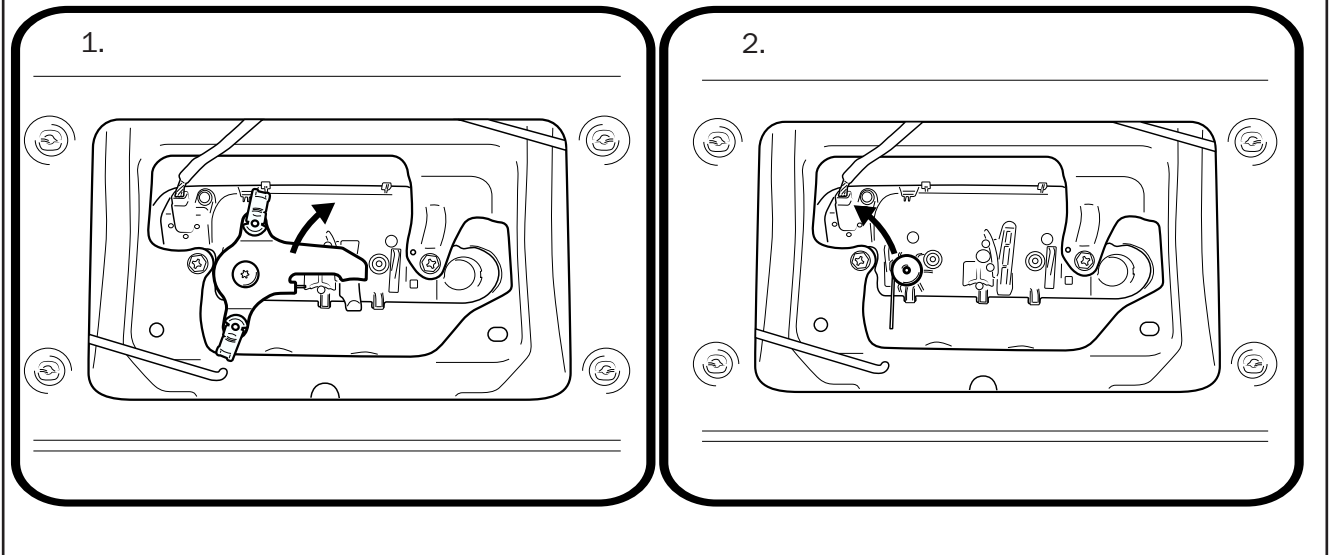

— STEP 8 —

- (i) Remove rod clips from factory cam.
- (ii) Refit them to C18-A bracket.

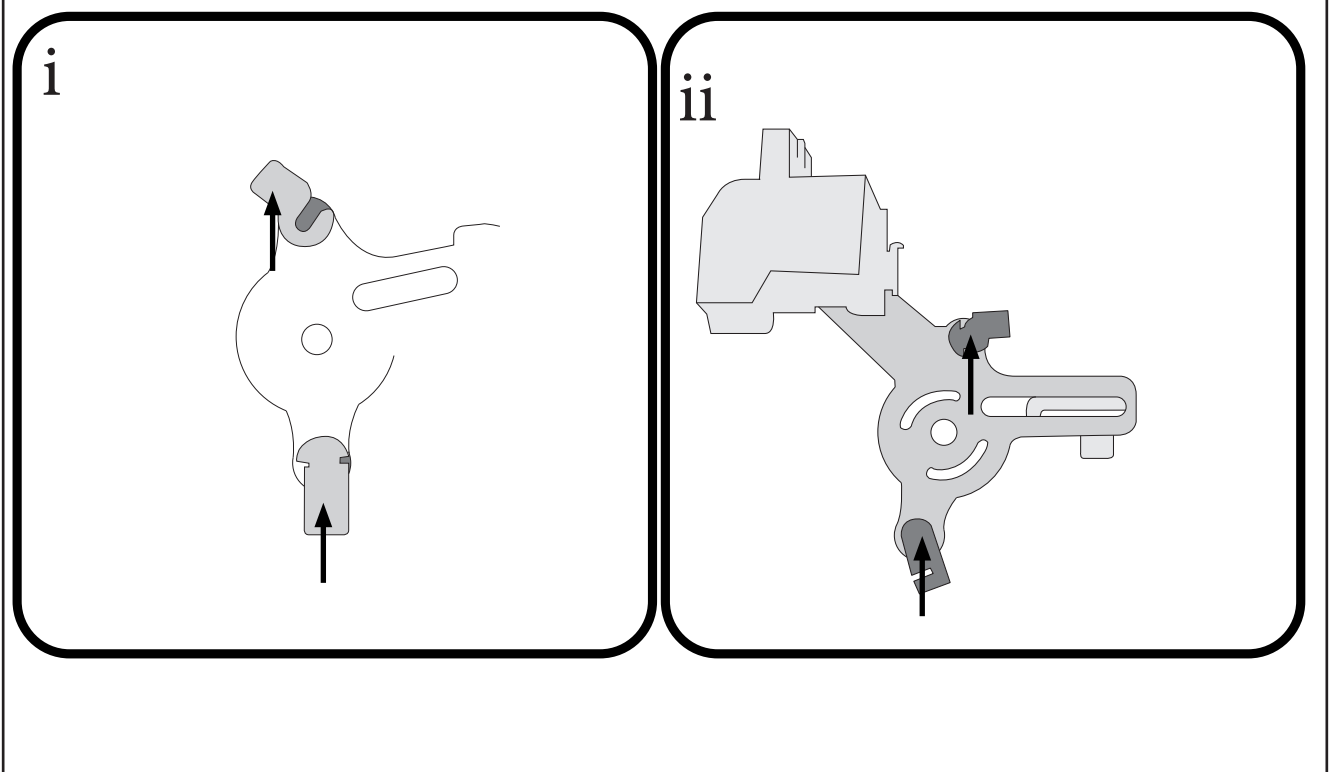

— STEP 9 —

Place the Tail Lock assembly as shown.

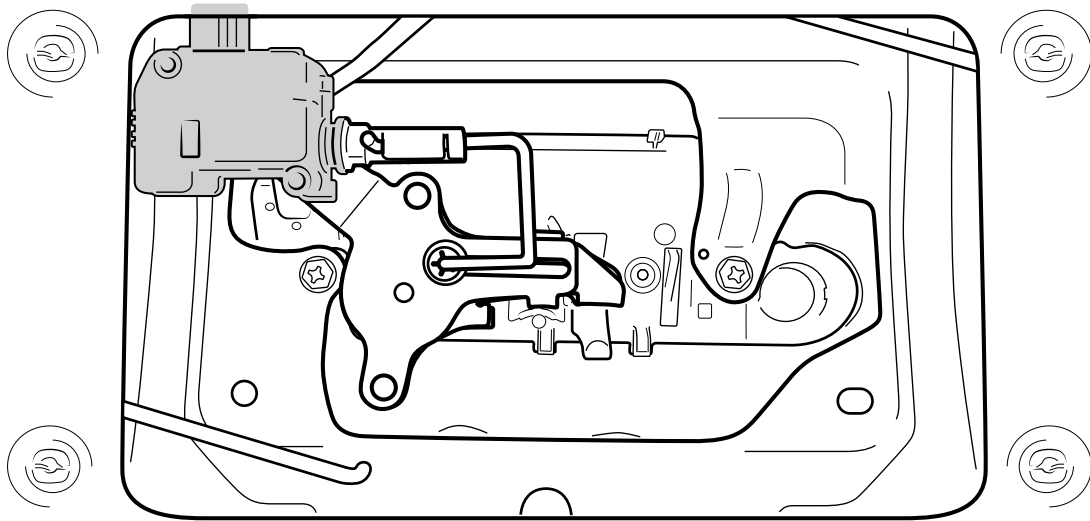

— STEP 10 —

Fasten the assembly using the shoulder bolt provided part number C18-D).

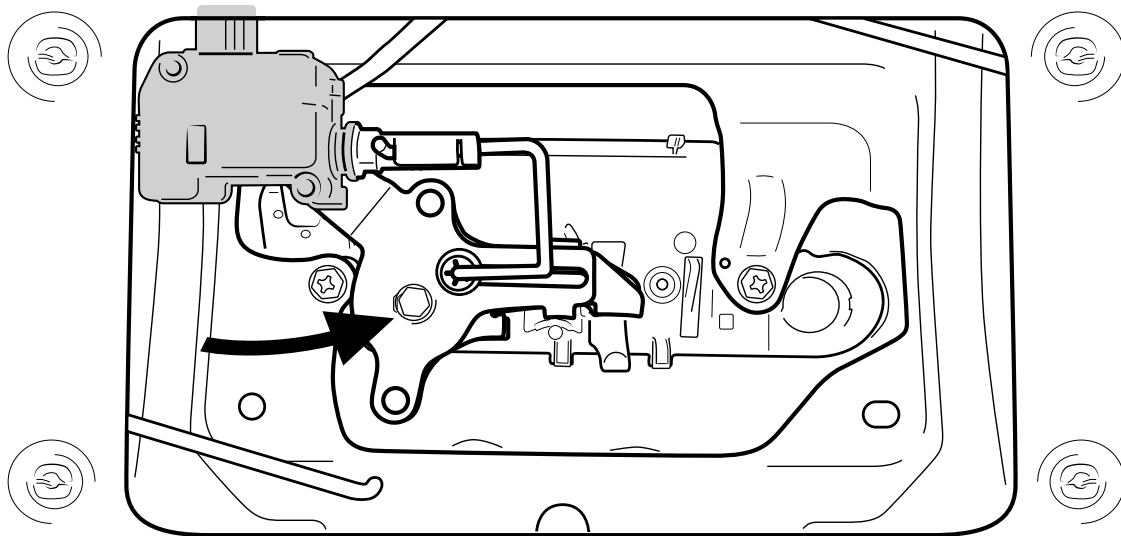

— STEP 11 —

Clip the spring in place

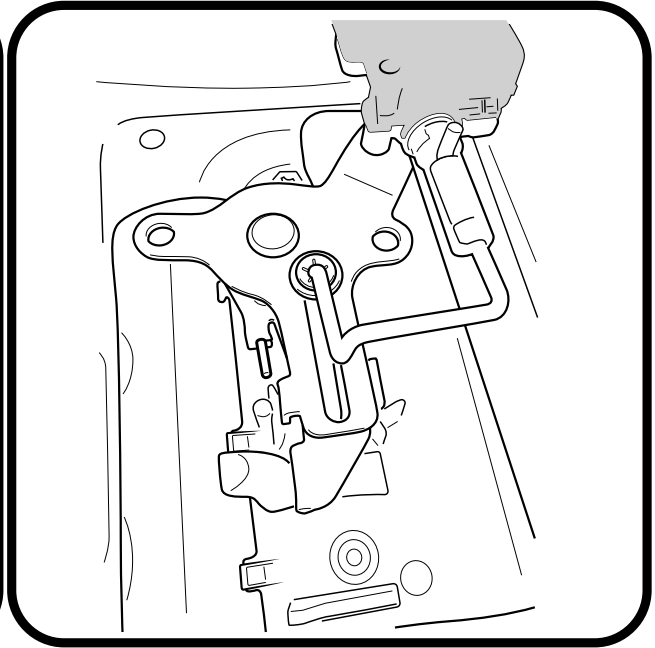
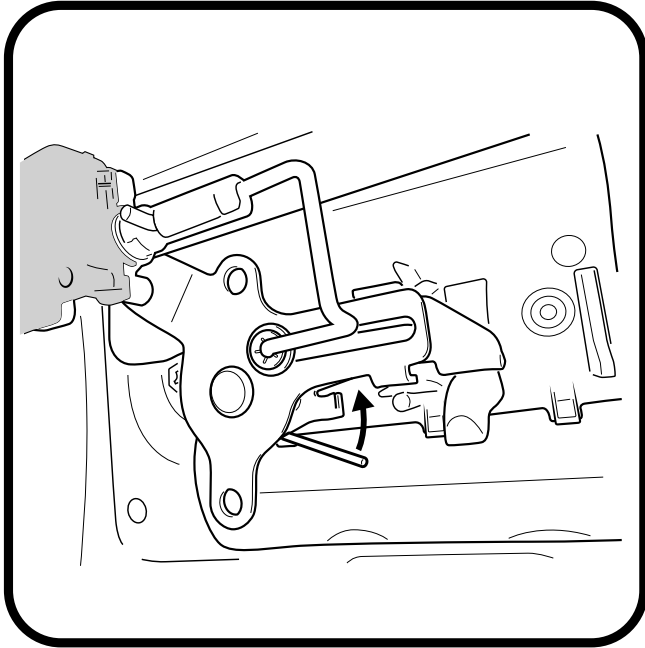

— STEP 12 —

Re connect the rods in to the rod clips.

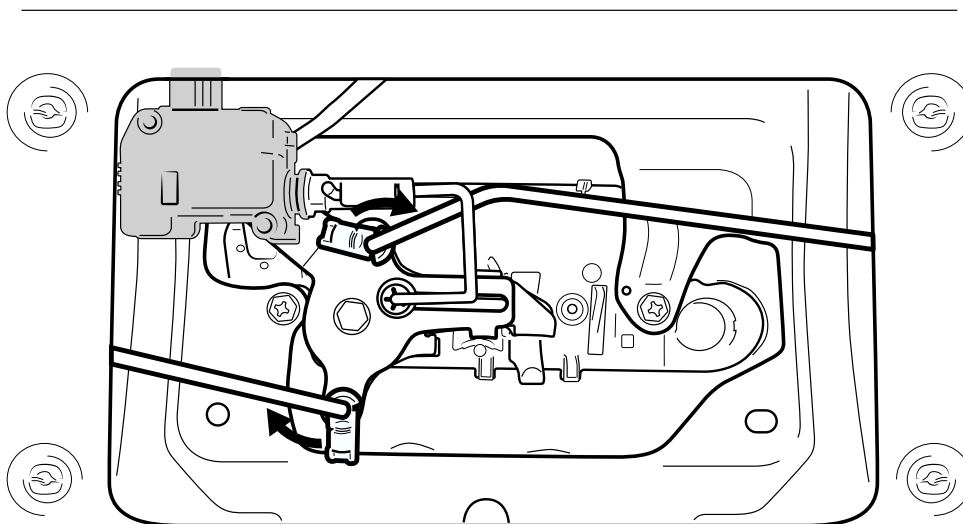

— STEP 13 —

Connect the wiring to the actuator then route the actuator wiring harness (1) out of the tailgate and underneath the vehicle following the existing vehicle harness.

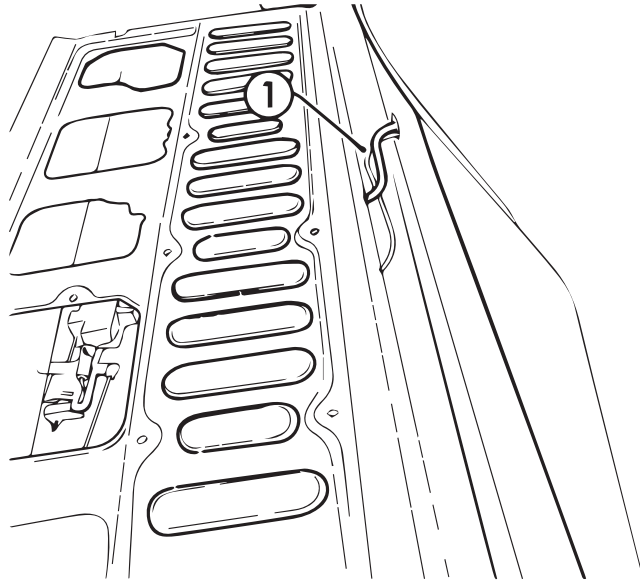

— STEP 14 —

Run wiring (CL-LONG-LOOM) from tailgate to front passenger door over chassis rail.

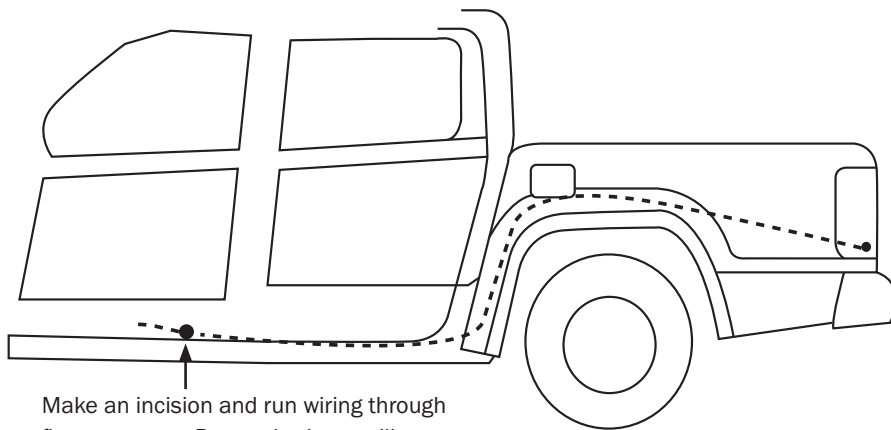

Make an incision and run wiring through floor grommet. Remembering to silicon when finished.

—STEP 15—

Carefully remove the passenger side scuff and kick panel.

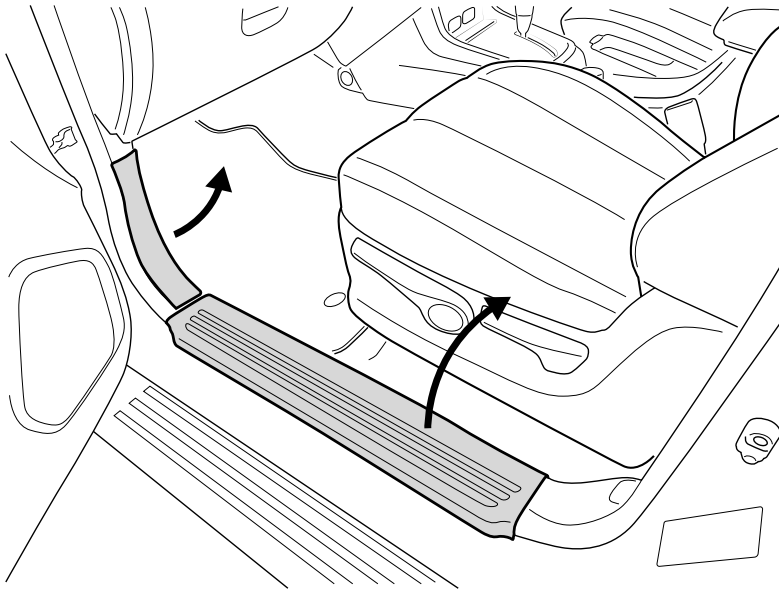

—STEP 16—

locate the central locking loom connector.
It will be deep in the pillar cavity leading towards the door.
Now disconnect the plug.

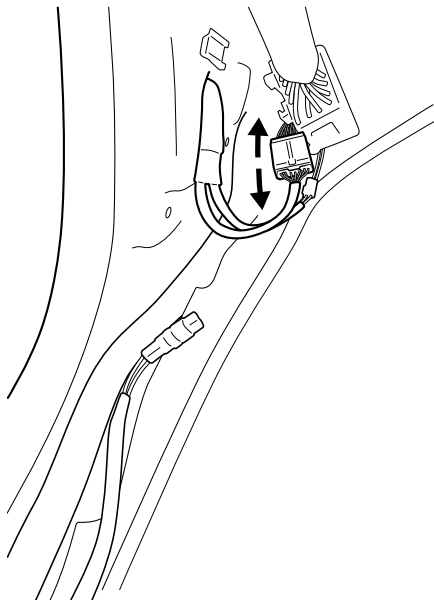

— STEP 17 —

connect the C-patch connector provided to the vehicle connector (piggyback)

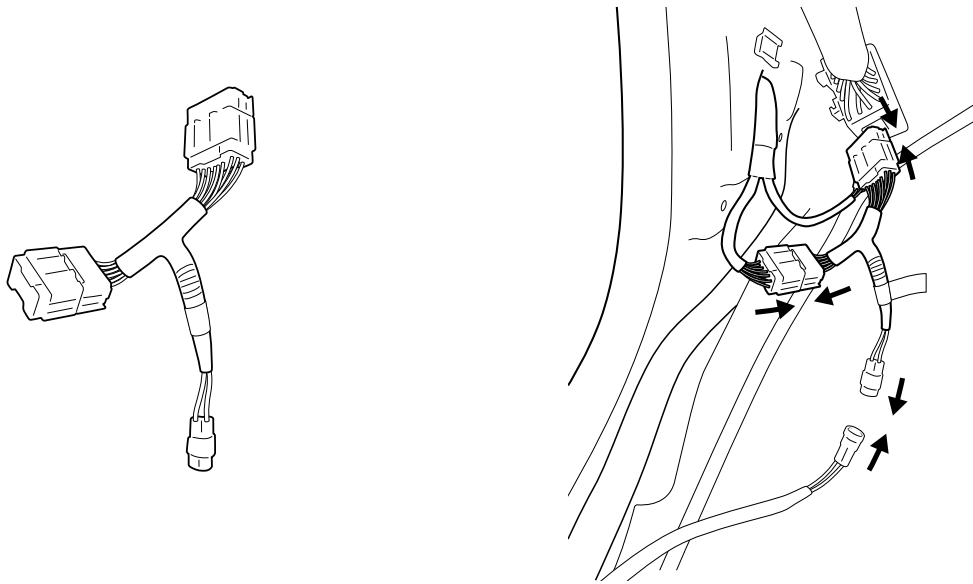

Now connect the C-Patch to the CI-Long-Loom

— STEP 18 —

Carefully re-fit the passenger side scuff and kick panel.

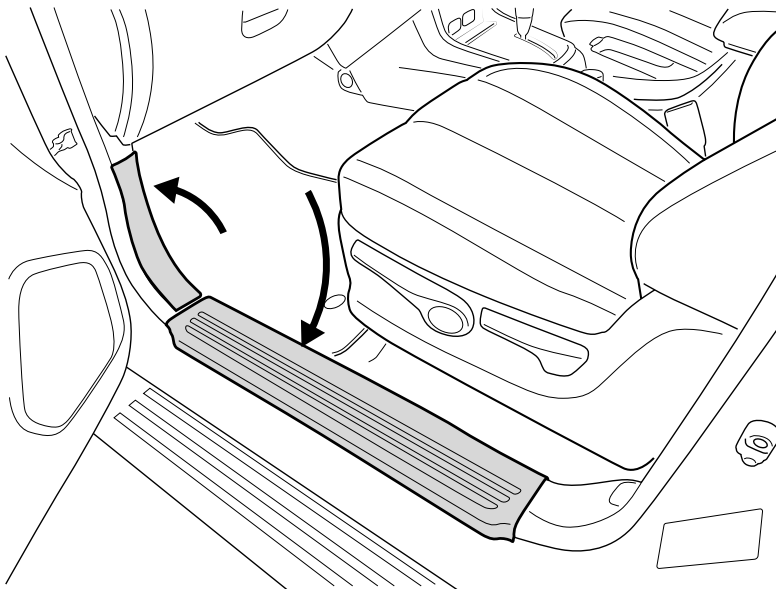

— STEP 19

Place and fasten tail gate cover.

