

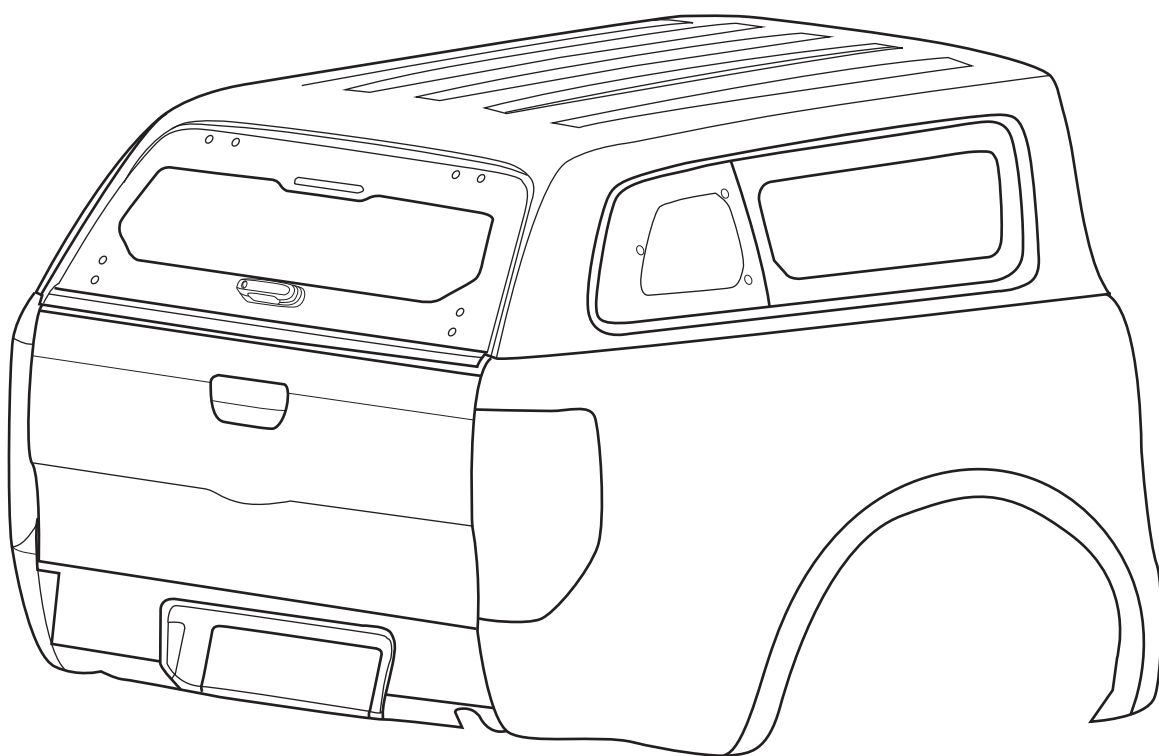

# INSTALLATION MANUAL

## CANOPY FORD RANGER PX



### **FOR ENQUIRIES ON SERVICE :**

#### **AUSTRALIA :**

AEROKLAS AUSTRALIA PTY., LTD.

1831-1833 Sydney Rd, Campbellfield, Vic, 3061

F: (03) 9930 0801 Email: [service-au@aeroklas.com](mailto:service-au@aeroklas.com)

#### **AEROKLAS CO., LTD.**

62 Soi Bangna-Trad 25, Bangna-Trad Rd. Bangna, Bangkok 10260 THAILAND.

Tel: (662) 7443020 Direct Line: (662) 7443034-5 Fax: (662) 7443033

[www.aeroklas.com](http://www.aeroklas.com) E-mail: [webinfo@aeroklas.com](mailto:webinfo@aeroklas.com)

**STYLISH**

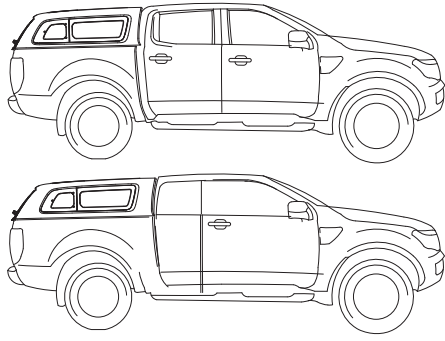

**COMMERCIAL**

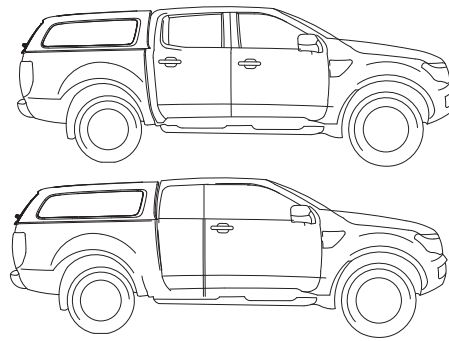

**D/C**

**RAP**



**X4**

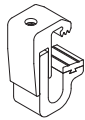

**X4**



**X4**



WITH CARGO BOX LAMPS



**X2**

WITH OUT CARGO BOX LAMPS

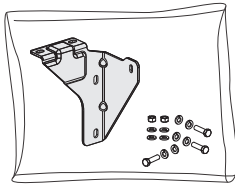

**X2 (RH /LH)**

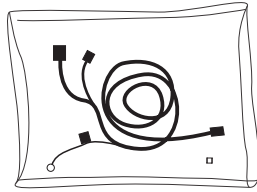

**X1**

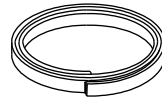

**X1**

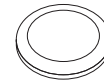

**X3**



**X12**



**X1**

JUMPER HARNESS FOR SERIES II  
WITH CARGO BOX LAMPS

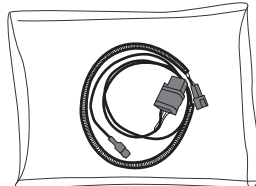

**x1**

DEMIST OPTION WIRE

**SPECIAL TOOLS**



**No.10,12**

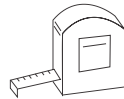

**No.5**

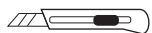

**Silicone**

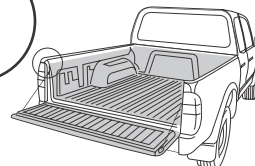
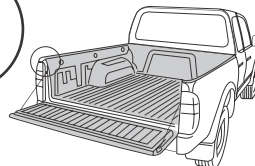
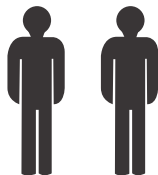

**1-17**

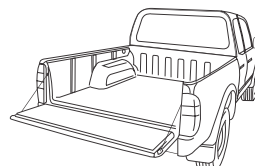

**1-17**

1

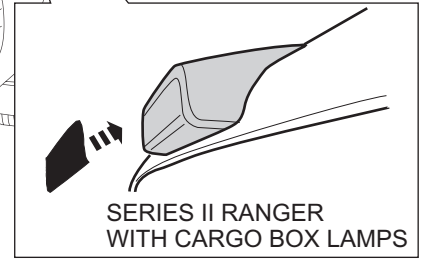
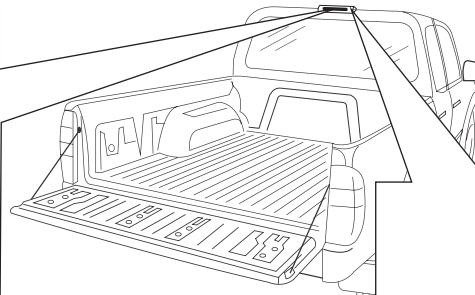
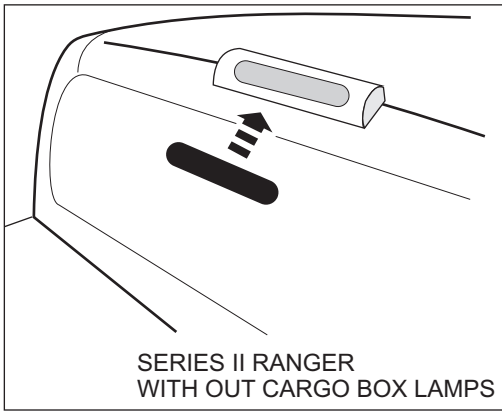

2

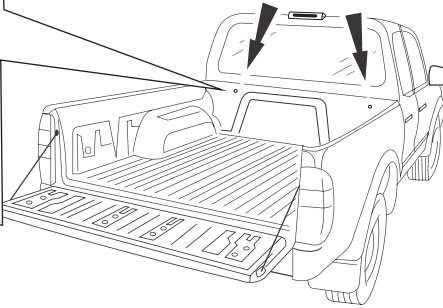
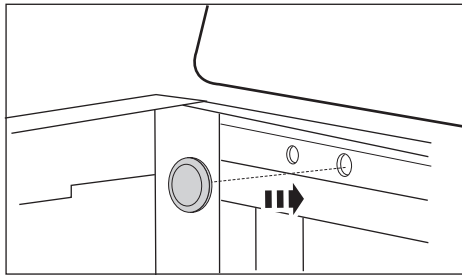

3

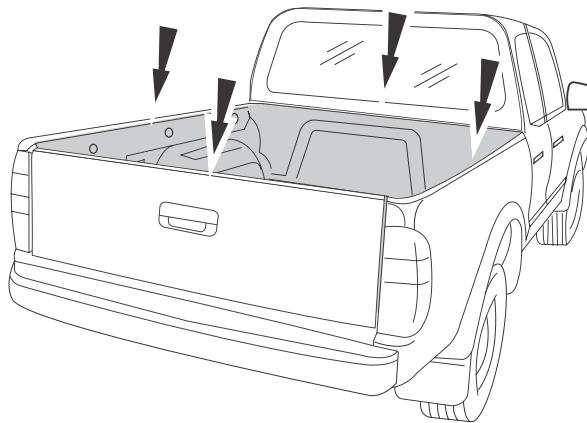

4

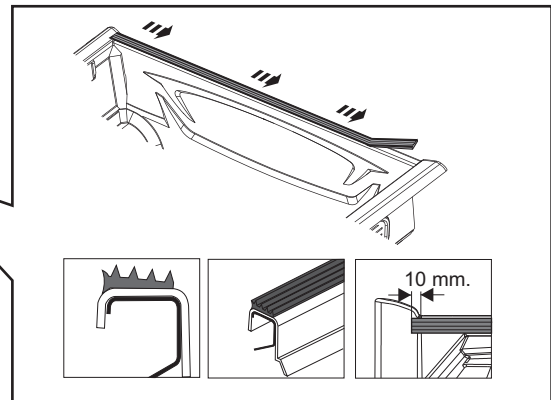
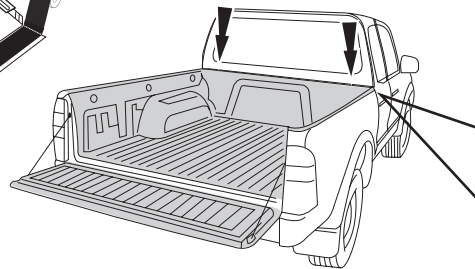
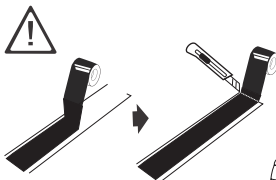

DEMIST OPTION

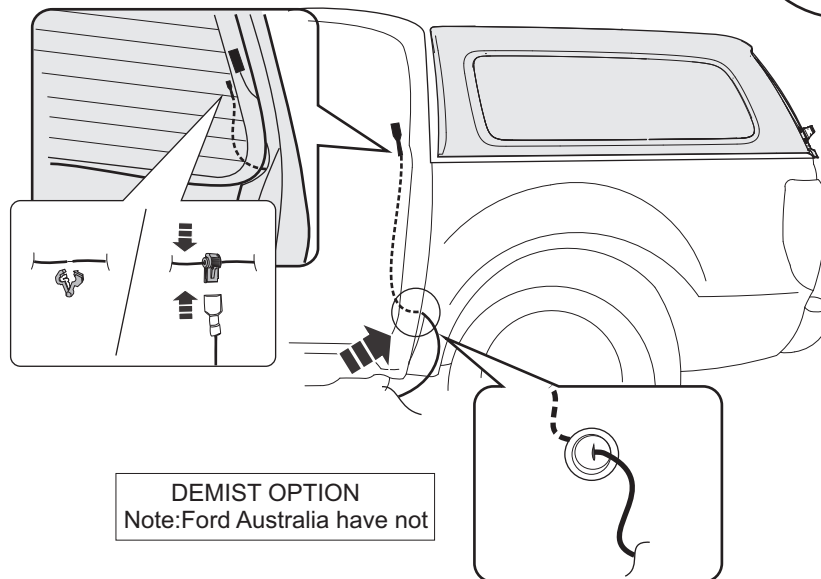
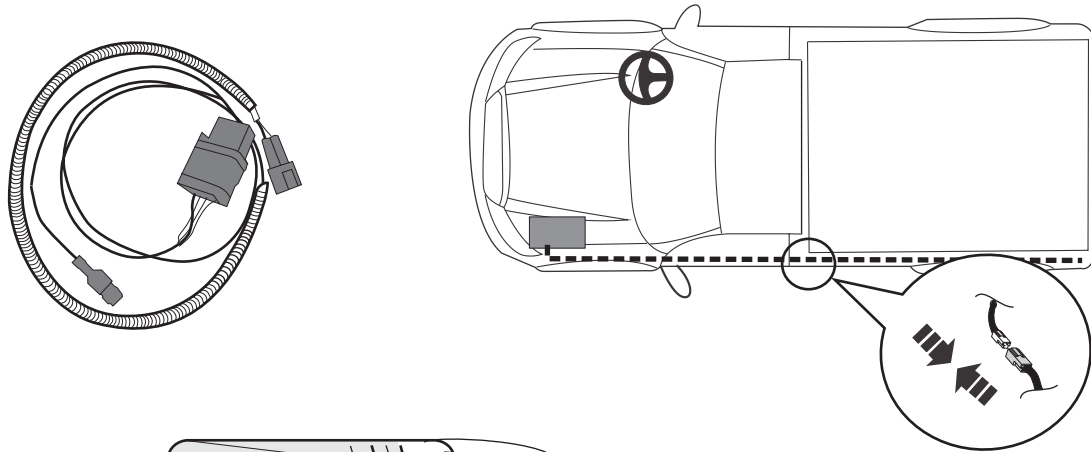
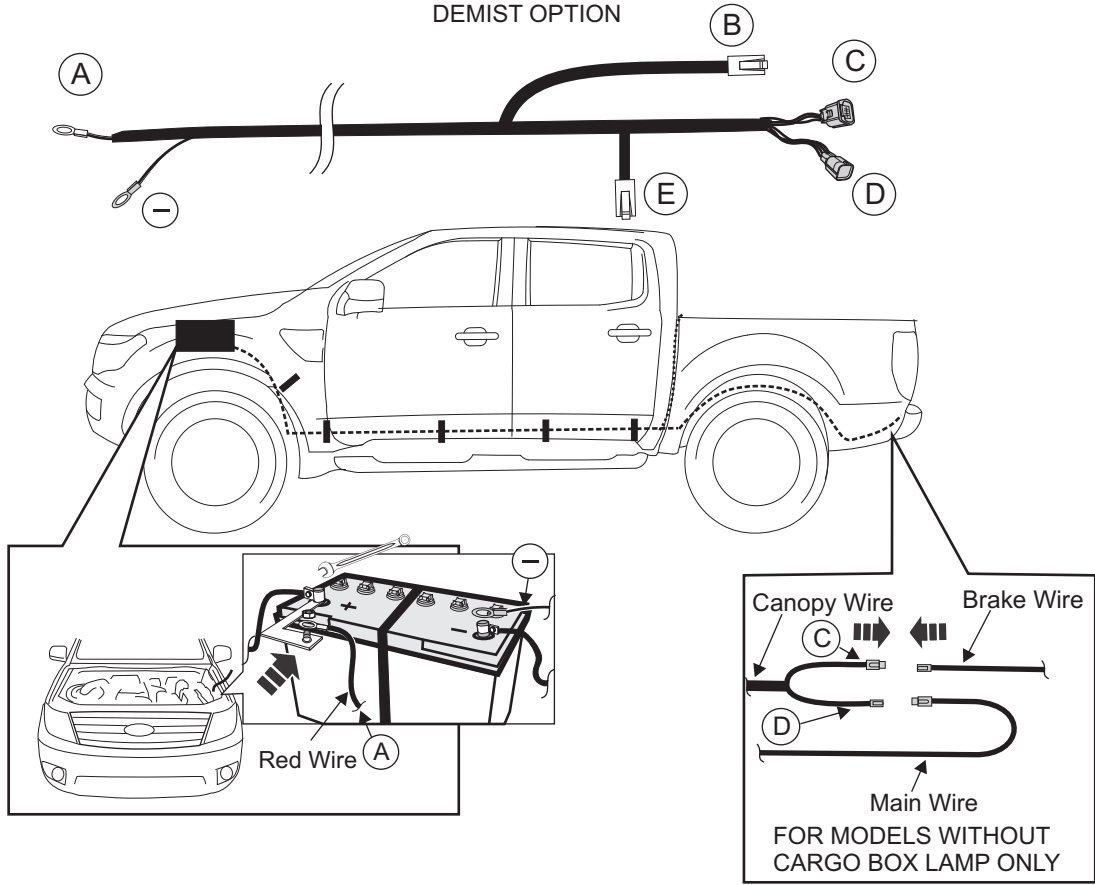

DEMIST OPTION  
Note: Ford Australia have not

# WIRING-DIAGRAM FORD T6 ARK-RKE (PLUG AND PLAY) (LH)

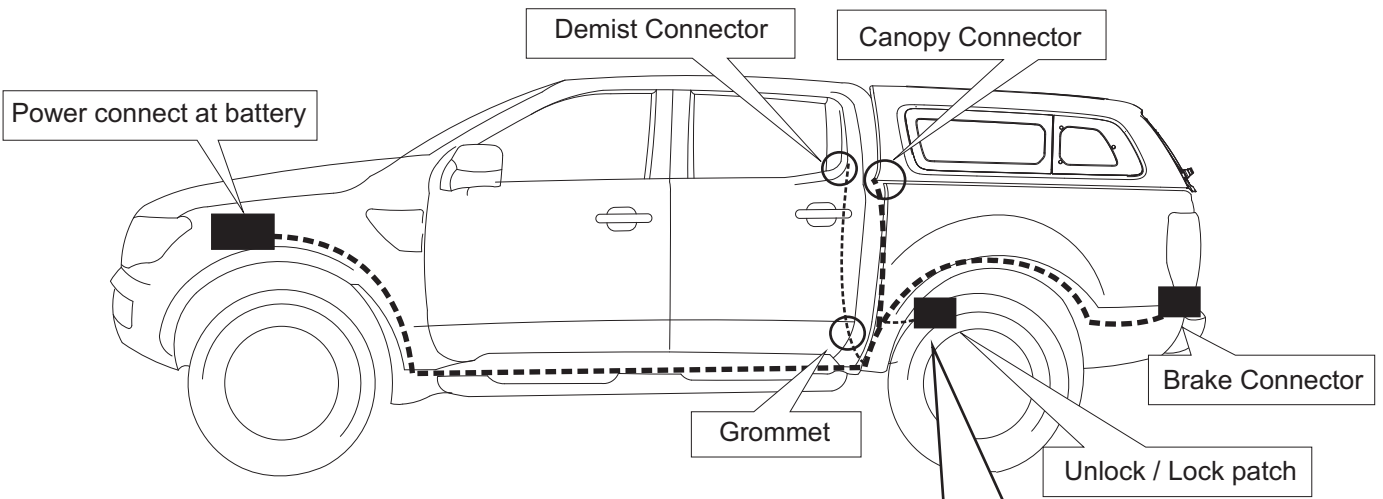

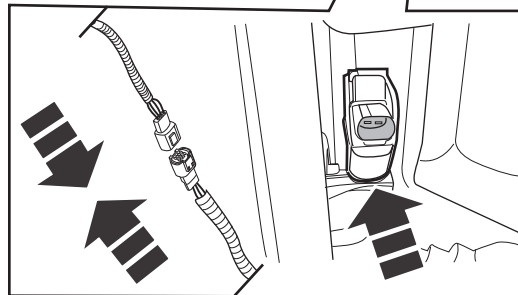
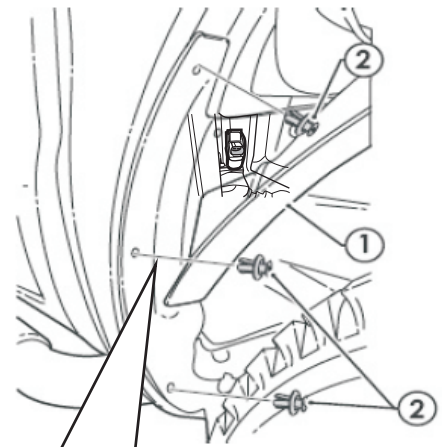
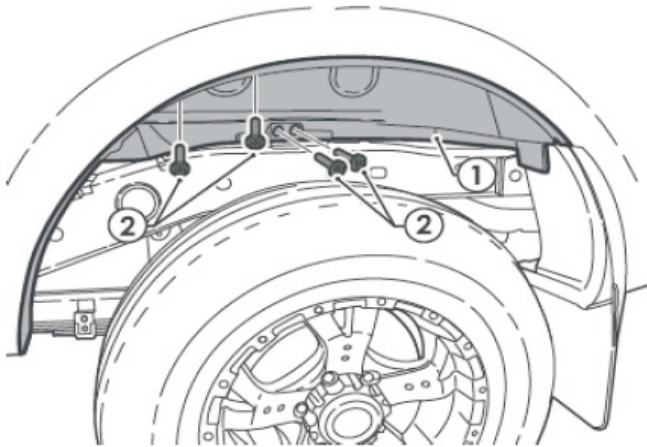

**NOTE.** For Ford T6 FOA series II cargo box lamps.  
1. Lock / Unlock connect at fuel door connector by co signal with vehicle.

## 5.1

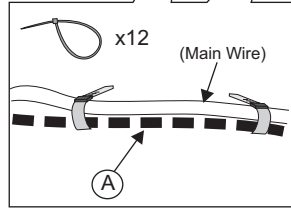
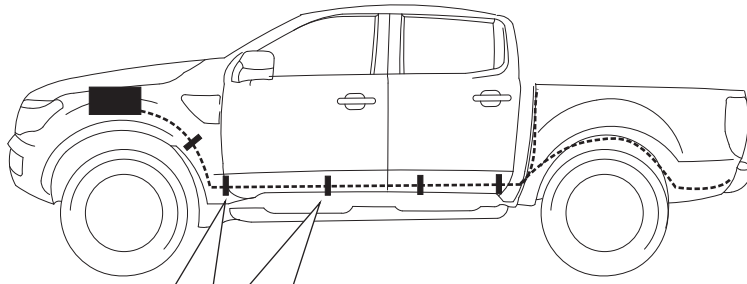

6



 = (A) (Canopy Wire)  
 = (Main Wire)



7

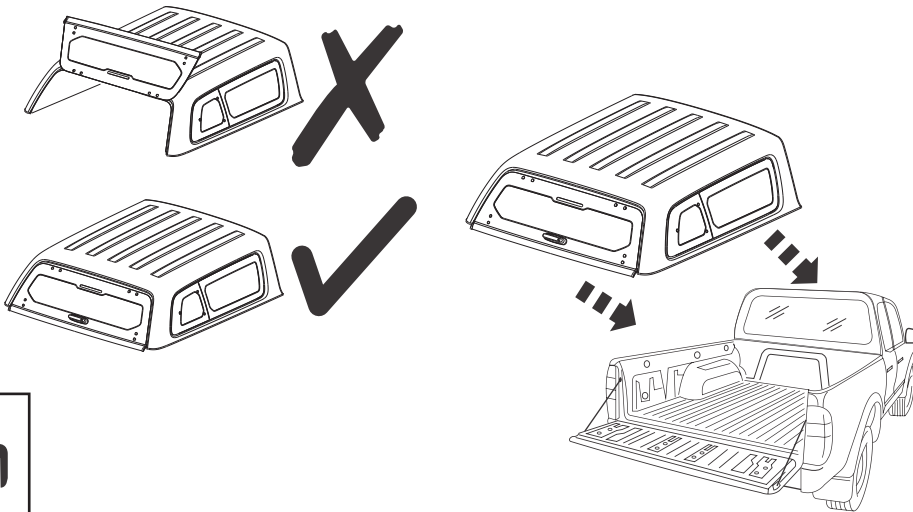

8

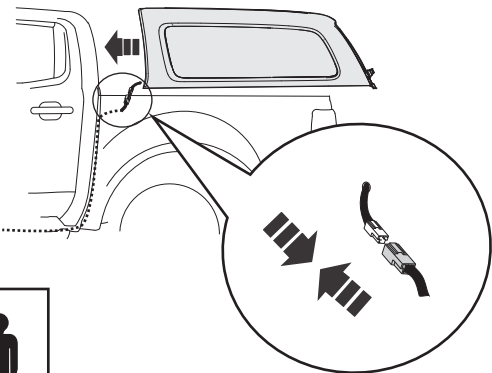
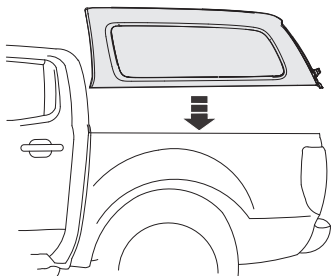

Tolerance =  $\geq 25$  mm.

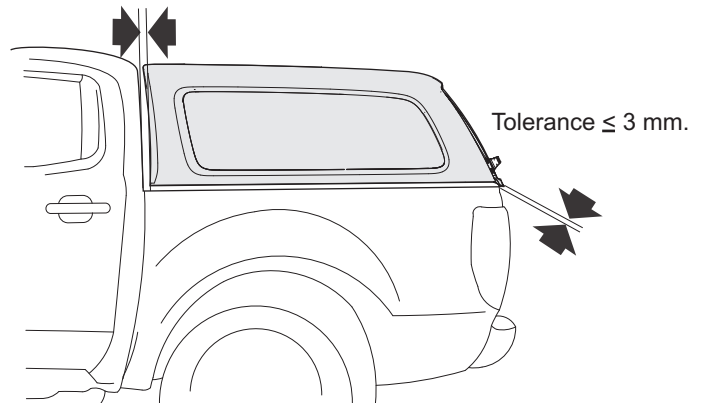

Tolerance  $\leq 3$  mm.

6-10 mm.

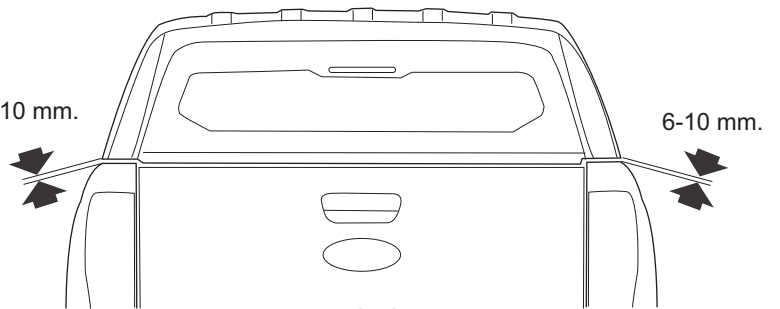

6-10 mm.

A=A

9

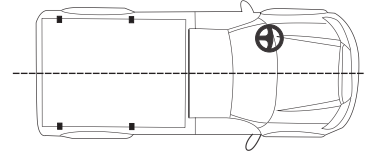
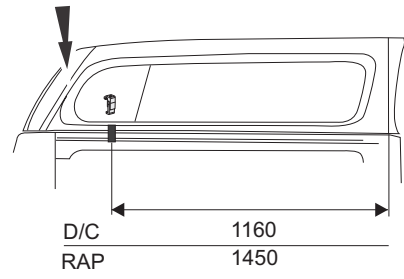
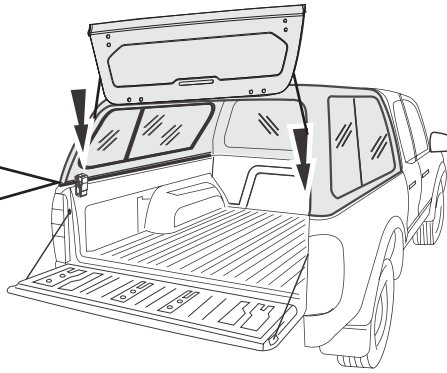
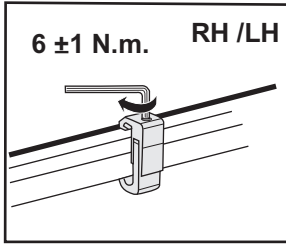

10

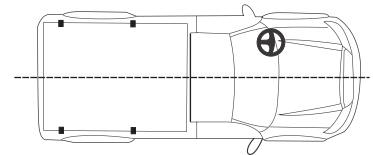
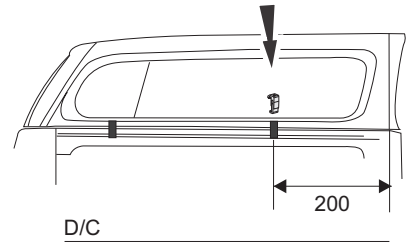
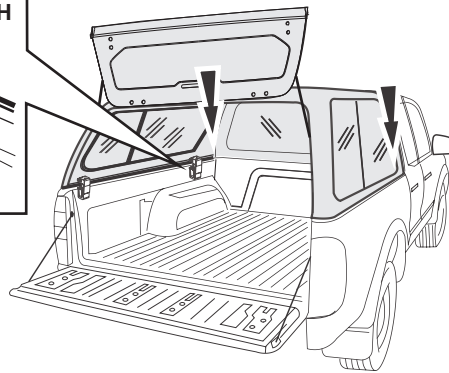
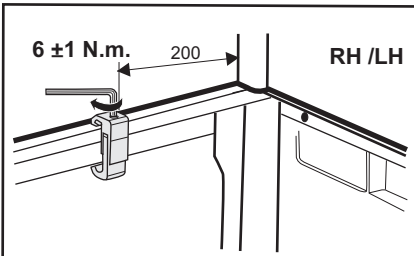

11

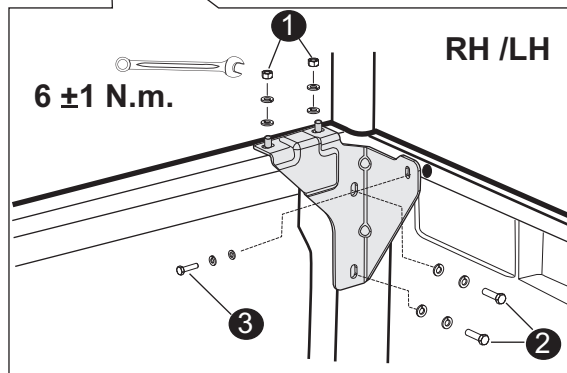
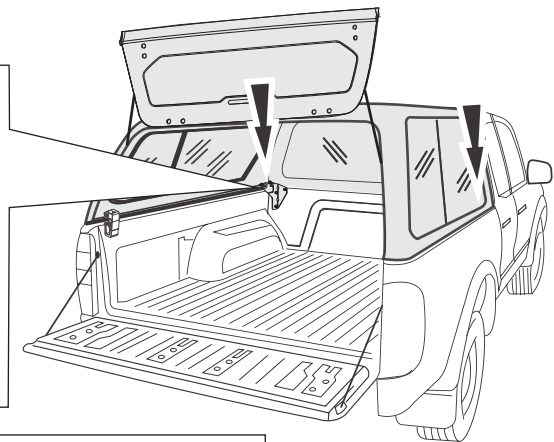
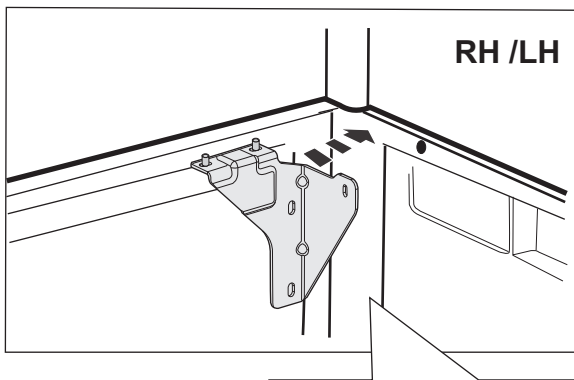

12

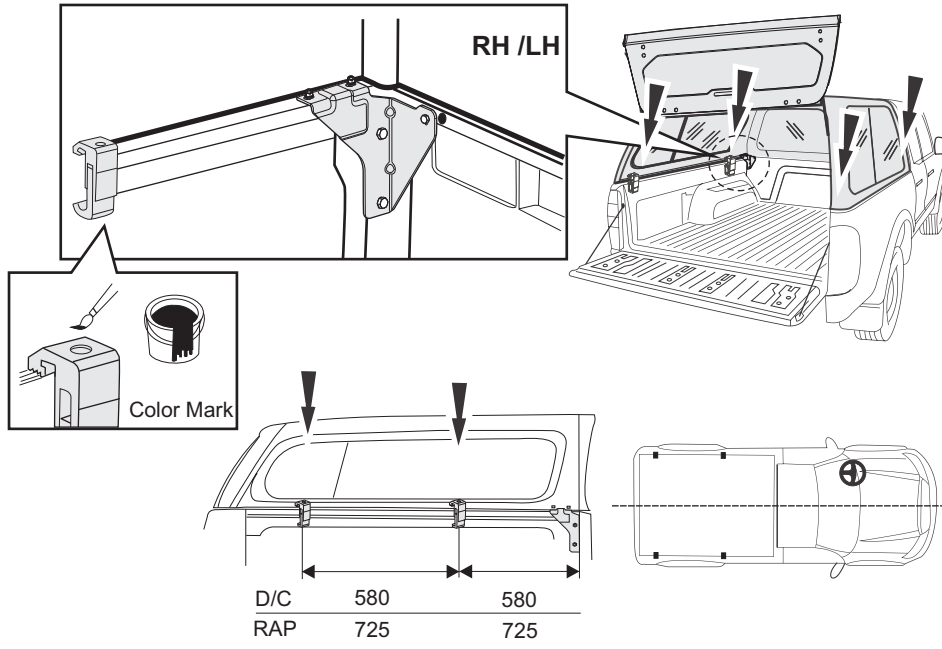

13

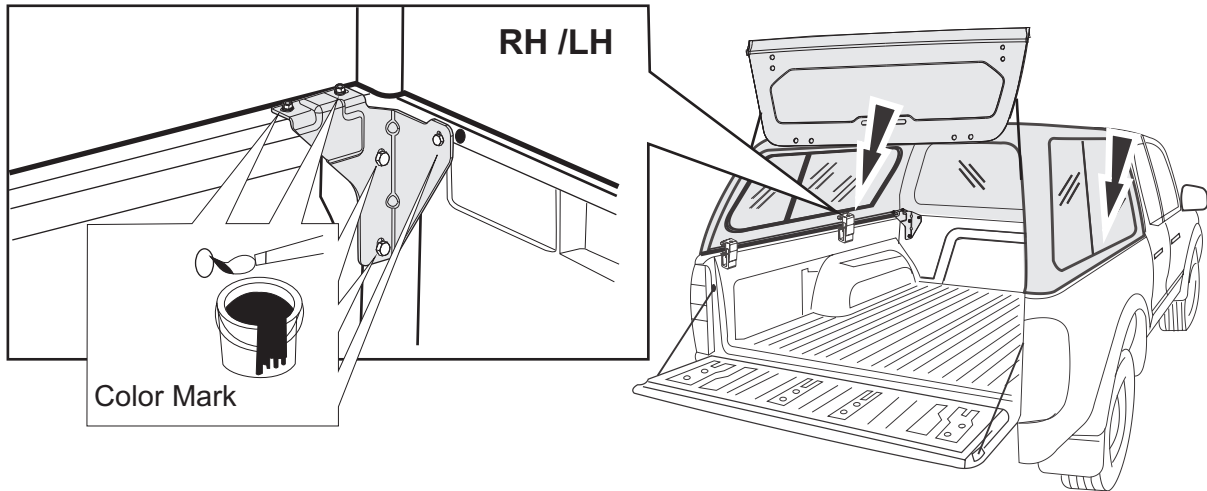

14

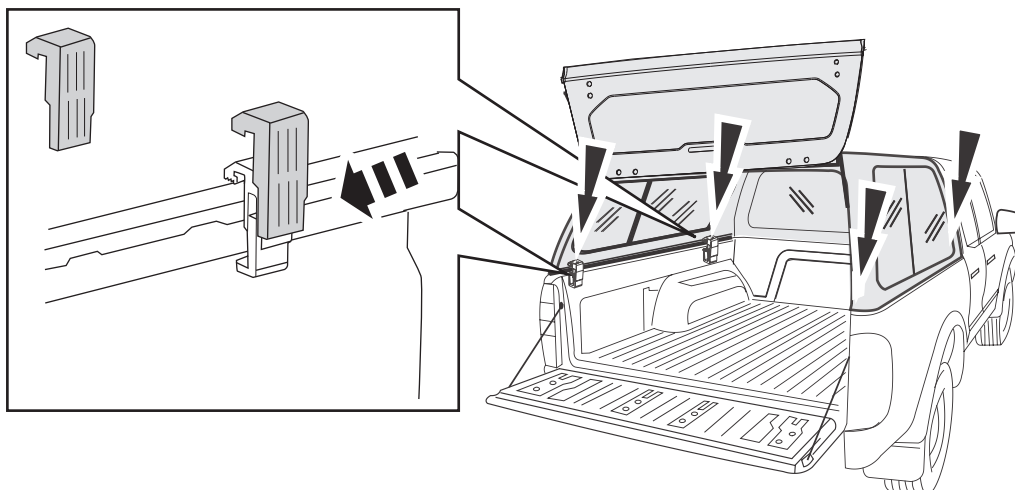





ADVICE

Sony Silicone Black No.L6301

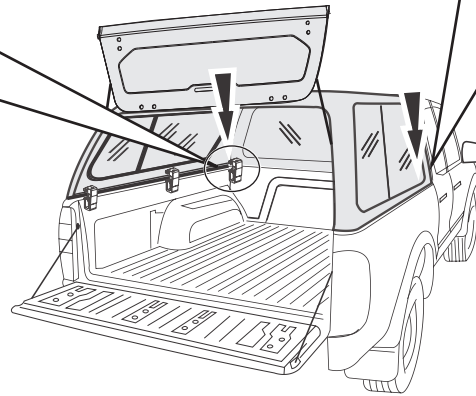
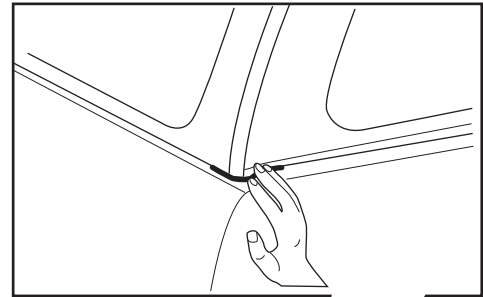
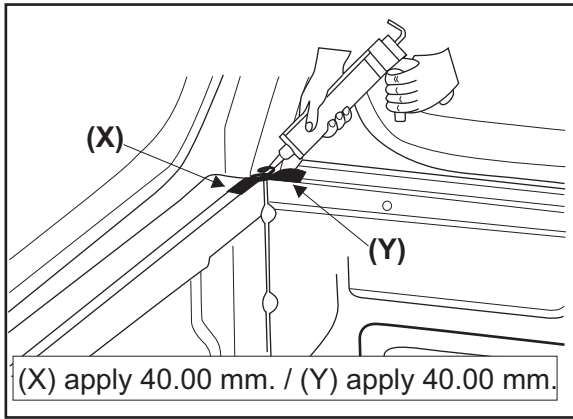

C-clamp 2 set+Front bracket

**WARNINGS!**

  5000 Km 3000 Miles 5 mm. 6 Nm.	 <b>WARNING</b> Do not drive the vehicle at speed with the tailgate opened. 	 5000 Km 3000 Miles 	 <b>WARNING</b> Heated rear screen should be turned off after defrosting. Not for extended use. 
---	---	-------------------------------	--



# Wiring diagram for T6

## Wiring

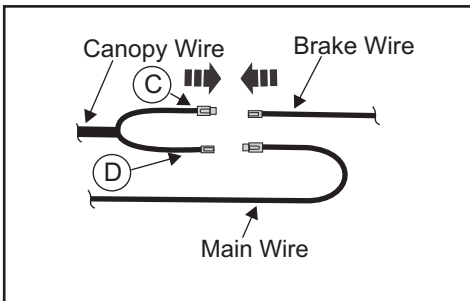
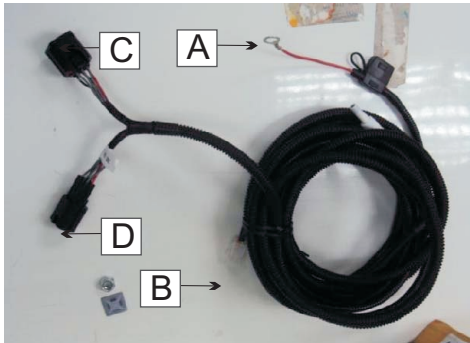

## Connector for RKE Lock / Unlock system

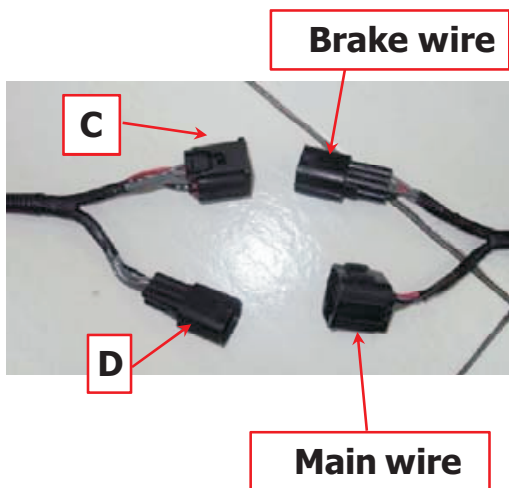

Point	Photo	Function	Referance maual
A		Connect with battery Anode and cathode	
B		Connect with Canopy	
C		Connect with main wire For model without cargo box lamp.	
D		Connect with brake wire For model without cargo box lamp.	
D2		Connect with brake wire For model with cargo box lamp.	
E		Connect with fuel door Connector for RKE Lock / Unlock system	

# Amendment for FORD RANGER PX2 with Cargo Box lamps: JUMPER WIRE HARNESS Installation.

## – Step 1

Note: If the PX2 Ranger is fitted with the following equipment:

- WILDTRAK FITTED WITH HOOP BAR CHMSL & CARGO LIGHTING.
- XLT WHERE FITTED WITH TUBULAR SPORTS BAR CHMSL & CARGO LIGHTING.
- XL / XLS WITH REVISED CHMSL & CARGO BOX LIGHTING.

Then proceed to use the JUMPER HARNESS part when fitting an Aeroklas Canopy Wiring Kit.

### Important



Always refer to the vehicle's Workshop Manual when removing vehicle components.

- Note down all clock and radio settings
- In the engine bay, disconnect the negative battery terminal.

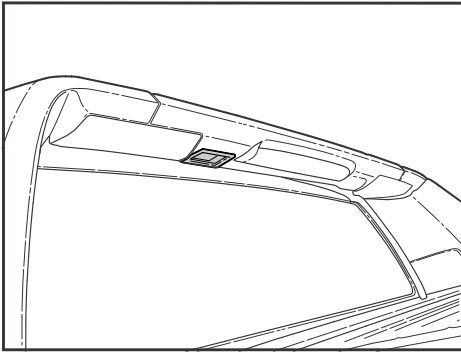

WILDTRAK FITTED WITH HOOP BAR CHMSL & CARGO LIGHTING.

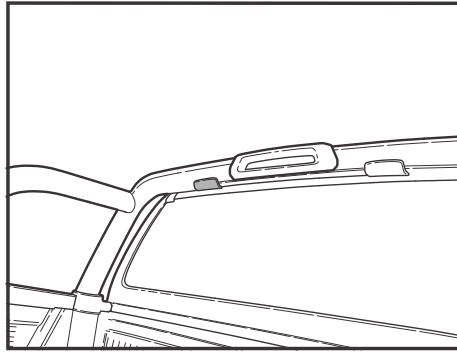

WITH TUBULAR SPORTS BAR CHMSL & CARGO LIGHTING.

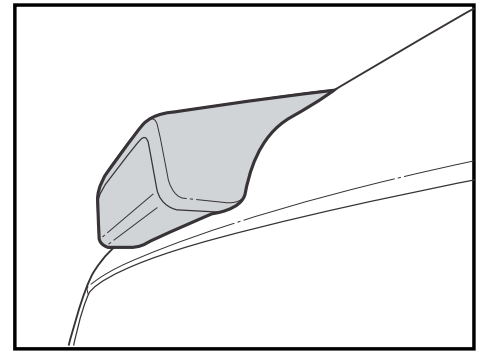

WITH REVISED CHMSL & CARGO BOX LIGHTING.

## – Step 2

- In the LHS rear wheel arch, remove the wheel arch trim (1) by first releasing the four trim clips (2).

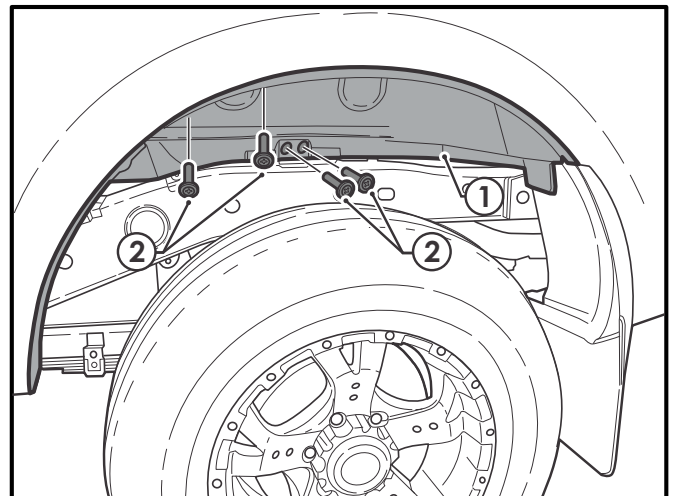

# Amendment for FORD RANGER PX2 with Cargo Box lamps: JUMPER WIRE HARNESS Installation.

## – Step 3

- Remove the lower LHS wheel arch (1) by removing the 3 scrivenets (2).

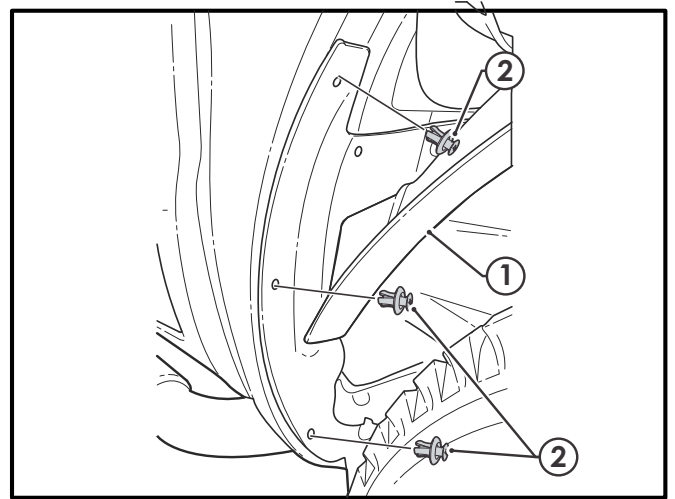

## – Step 4

- Locate the 4-way grey connector (1).
- Disconnect the female connector (2).

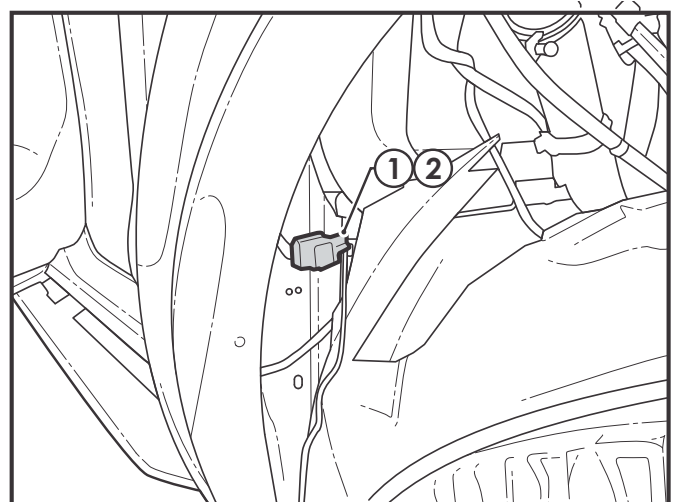

## – Step 5

- Coil up Aeroklas canopy main harness at rear of the cab, then tie cable into a loop.
- Pull the 6-way connector patch (1) back towards the front of the rear wheel arch area near the connector located in Step 4.

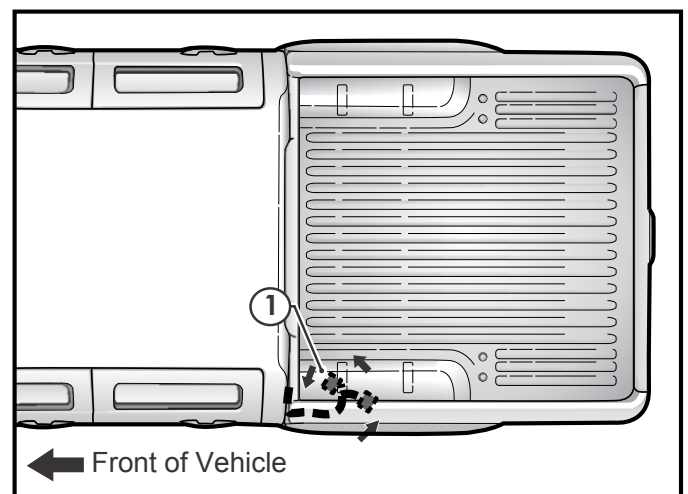
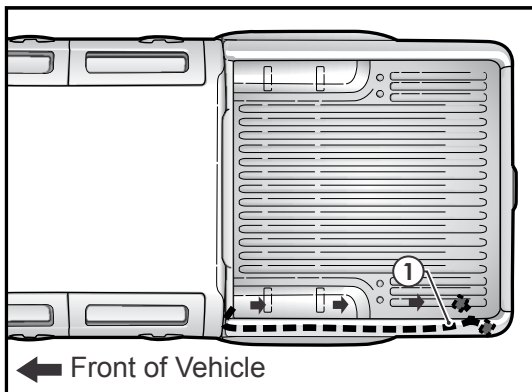

**FIT JUMPER HARNESS TO MODELS WITH CARGO BOX LIGHTING.**

**(NOTE) DO NOT FIT JUMPER HARNESS TO MODELS WITHOUT CARGO BOX LIGHTING.**

# Amendment for FORD RANGER PX2 with Cargo Box lamps: JUMPER WIRE HARNESS Installation.

## – Step 6

- Connect the 6-way male connector (1) on the Canopy Harness (2) to the 6-way female connector (3) on the Jumper Wire Harness (4).
- Connect the 6-way female connector (5) on the Canopy Harness (2) to the 6-way male connector (6) on the Jumper Wire Harness (4).

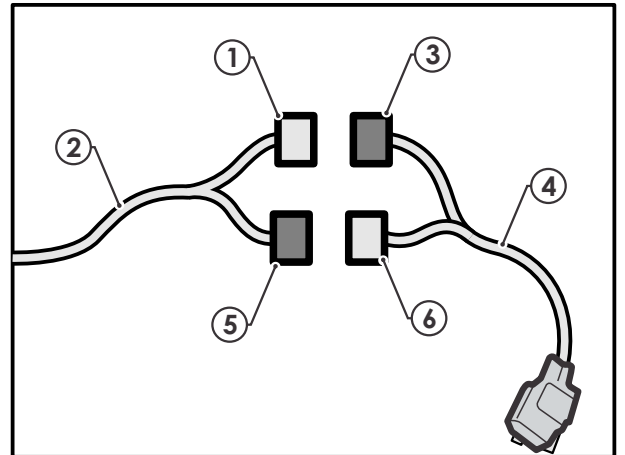

## – Step 7

- Refit connector to rear body harness.
- Bundle & cable tie excess harness to avoid rattle conditions on the vehicle.
- Refit all removed parts of wheel house liner.
- Reconnect the negative battery terminal.

### Important



Refit all removed parts and secure all fasteners as per Service Manual torque specifications.



Please place the Installation Manual in the glove box after installation is completed.

