



# FITTING INSTRUCTIONS

070AP15N88K  
070SB15N88K  
E074SB17L88K

FITTING INSTRUCTIONS FOR A T15/T17 BAR  
TO SUIT TOYOTA PRADO 6/96+ & 8/99+

FTOY105

PAGE 1 OF 5

1. Remove the grille from the vehicle. Remove the three plastic clips securing the rear edge of the top of the bumper bar. Remove the two bolts securing the rear edge of the underside of the bumper bar. Remove the screws securing the outer ends of the underside of the bumper bar to the inner plastic guards. Remove the screws securing the upper outside ends of the bumper to the underside of the front mudguards. Remove two bolts from each side securing the bumper bar mounts to the outside of the body mount brackets. Retain bolts. Disconnect foglight wiring. Carefully slide the bumper bar forward away from the vehicle.
2. Tape up and secure the foglight terminal blocks with electrical tape.
3. Remove the tow hook and tie down hooks from the underside of the chassis rails. Remove the crash absorbing extensions from the ends of the chassis rails by removing the centre bolts and then tapping upwards to release.
4. Remove grille support panel by removing three bolts, refer Diagram One. Retain centre bolt, discard panel and bolts.
5. Remove the headlight support panel by removing four bolts and two nuts securing to each side of vehicle. Retain nuts and bolts. Refer Diagram Two.
6. Position headlight support bracket (TP50-88K) supplied and secure using original bolts:
  - a) Secure two outside bolts with the M6 x 1.0 nuts, flat and spring washers supplied.
  - b) Secure two original front bolts with the M6 x 1.0 nuts, flat and spring washers supplied.
  - c) Secure two original nuts on captive studs on inside of bracket.
7. Secure grille support bracket supplied (TP54-88K) to front of bracket in centre of panel in front of radiator using original bolt. Ensure bracket is parallel to front of the vehicle. Refer Diagram Three.
8. Place chassis mounts (TP41A-88K), spacer plates (TP41B-88K) and mount braces (TP42-88K) in position on the chassis rails and secure to captive nuts in side extensions of chassis rails using M10 x 1.25 x 30 bolts, flat and spring washers (refer Diagram Four). Finger tighten only.

CHKD

APPD

REV FTOY105 A 21.01.00

BOLT TENSIONS	DIA (mm)	Nm	ft.lbs	DIA (inch)	Nm	ft.lbs
All bolt tensions are as follows > (unless otherwise specified)	5	5	4	1/4"	9	7
	6	9	7	5/16"	22	15
	8	22	16	3/8"	33	27
	10	44	32	7/16"	55	43
	12	77	57	1/2"	86	66



## WARRANTY

1. If any product or part of a product manufactured by TJM is found to be defective during a period of twelve (12) months after the date of purchase, TJM shall repair (at TJM's discretion) the defective product or part.
2. Any defect in a product distributed by TJM, but not manufactured by TJM, shall be dealt with in accordance with, and to the extent of, the warranty offered by the manufacturer of that product.
3. TJM does not warrant that the products manufactured by it comply with the laws of the place where those products are purchased or used. It is the sole responsibility of the Purchaser to ascertain whether products being purchased - or the affixation of those products to any other object - comply with local laws.
4. Except to the extent described in this warranty, TJM shall not be liable for any other claim, including those claims arising from faulty design, the use of the product on any indirect special or consequential damage or injury to any person, company or other entity.
5. Modification or alteration to any product manufactured by TJM to enable fitment in conjunction with other vehicle accessories or modifications (eg lift kits) will void any warranty claims.

OFFICES IN - BRISBANE o SYDNEY o MELBOURNE o CANBERRA o ADELAIDE o HOBART o PERTH o  
o DARWIN AND MANY REGIONAL CENTRES o

**DIAGRAM ONE >**  
**Remove grille support panel**

Remove three bolts securing grille guard support bracket

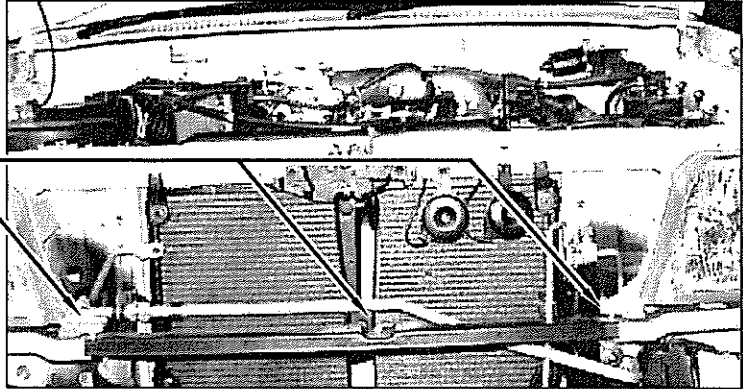

**DIAGRAM TWO >**  
**Remove headlight support panel**

Remove four bolts securing headlight support bracket

Remove two nuts

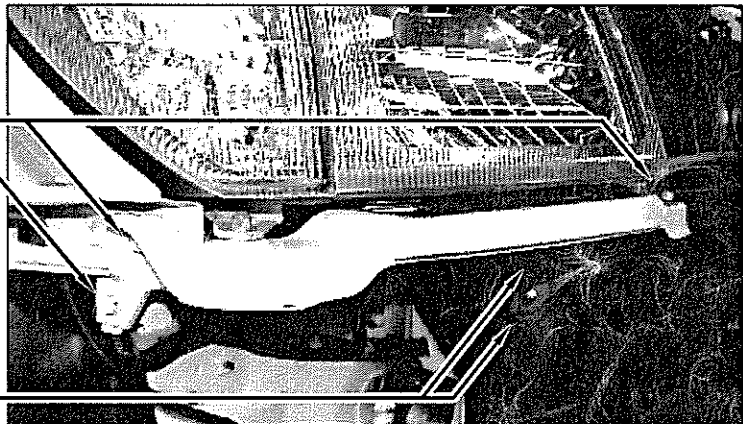

**DIAGRAM THREE >**  
**Secure grille support bracket**

Secure grille support bracket using original bolt

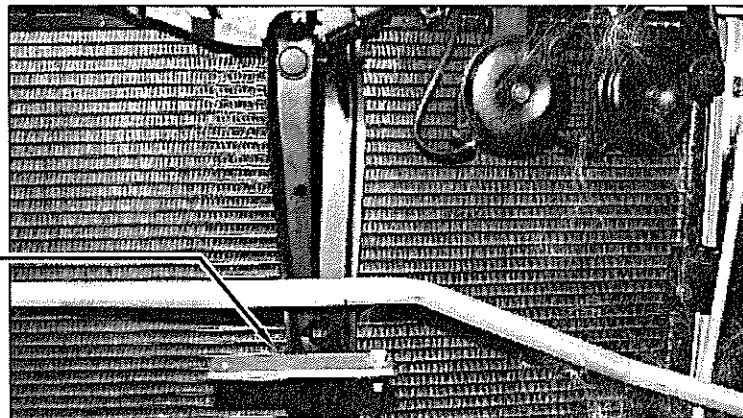

DIAGRAM FOUR >

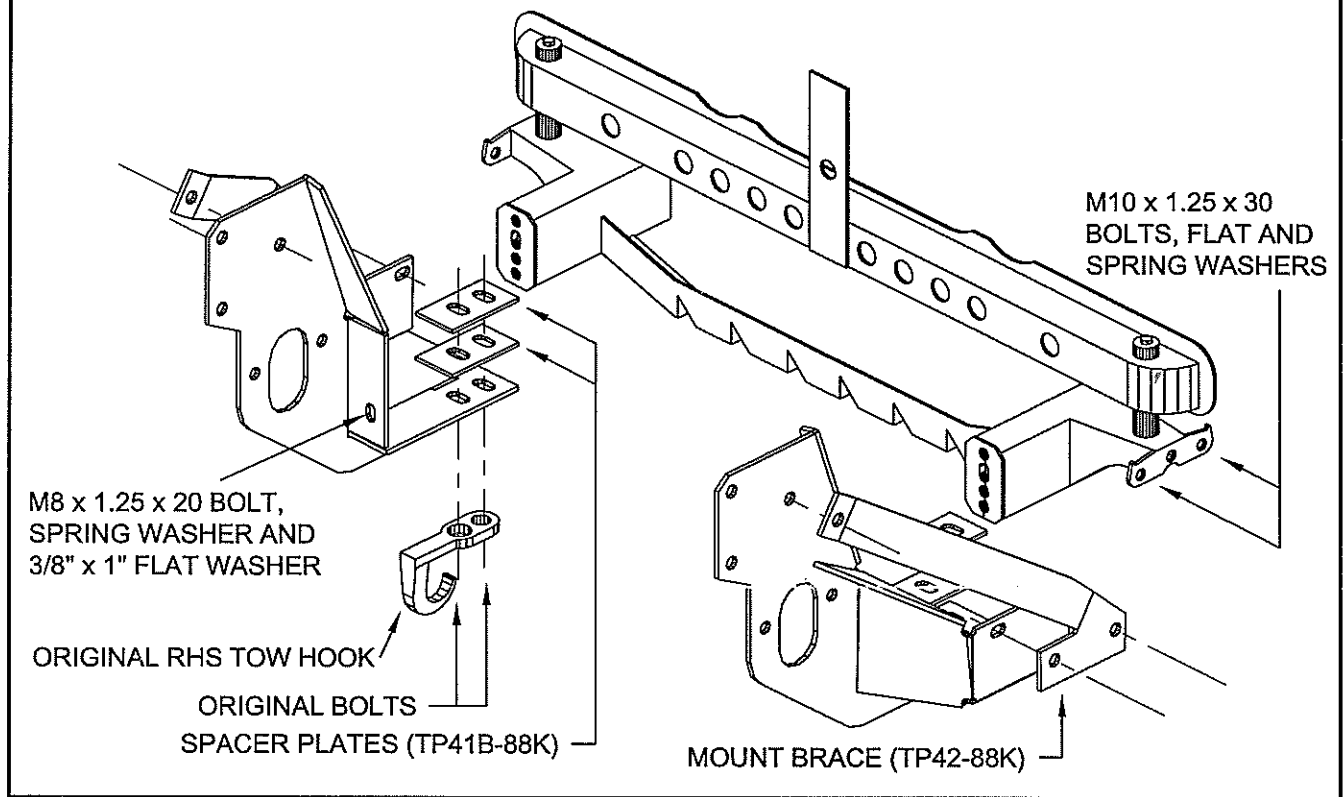
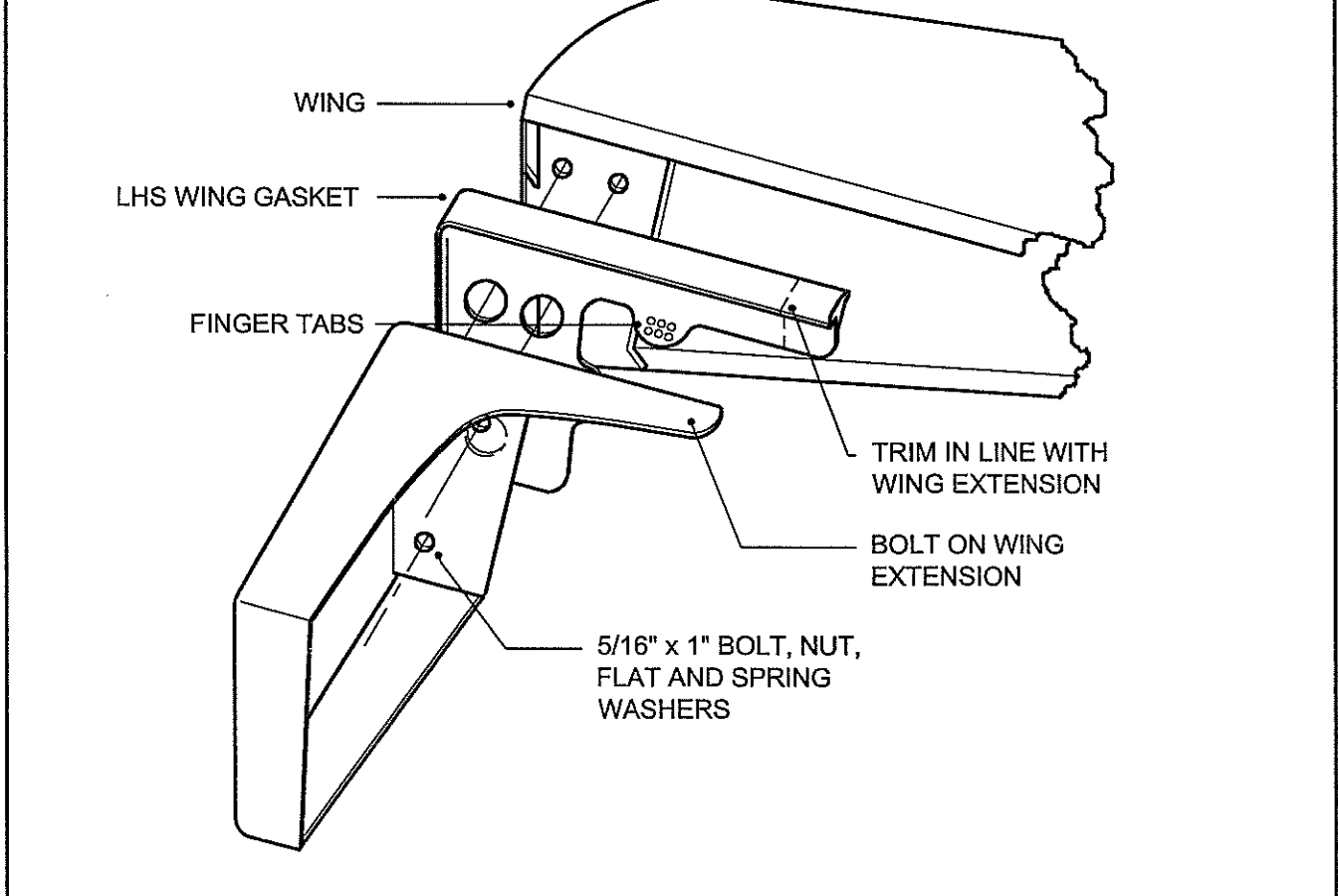

DIAGRAM FIVE >





- 9.** On the right hand side, refit tow hook and secure to the underside of the chassis rail through the chassis mount using the original tow hook bolts into captive nuts. On the left hand side, discard tow lug and secure mounts to the underside of the chassis rail using original tow lug bolts. Finger tighten only.
- 10.** Secure through the front of the mount into the captive nut in the end plate of the chassis rail using a M8 x 1.25 x 20 bolt with spring washer and a 3/8" I.D. x 1" O.D. flat washer. Finger tighten only.
- 11.** Align the mounts squarely with the vehicle and then tighten bolts.
- 12.** If winch is to be fitted refer winch frame fitting instructions now.
- 13.** Refer to Diagram Five. Bolt the wing extensions to the wings of the bar by inserting the plastic gasket in between the wing extension and the bar, ensuring the gasket is pulled in against the outer faces. Finger tabs on the gaskets will enable you to hold the gasket in place while tightening the bolts. Bolt through the holes using 5/16" x 1" bolts, nuts, flat and spring washers. Trim the top edge of the gasket, in line with the wing extensions.
- 14.** Carefully lift the bar into position on the vehicle. Align the holes in the bar mounts with those in chassis mounts and secure through the mount braces and chassis mounts using 1/2" x 1 1/2" bolts, nuts, flat and spring washers. Finger tighten only.
- 15.** Align the bar with the vehicle and then tighten bolts.
- 16.** Loosen the bolts securing the sump guard to allow the front edge of the guard to drop down. Position the air duct plate (TP30-88K) so that the three slotted holes on the edge align with the front sump guard securing bolts. Slide back into position and align the holes at the front with the holes in the lower skirt of bar. Secure to the bar using five M5 x 0.8 x 20 pan head screws, flat washers and nyloc nuts (only four required if winch frame fitted). Tighten all bolts.
- 17.** Replace vehicle grille, ensuring centre pin is located in grille support bracket.
- 18.** Cut notches in the plastic inner guards to align with the ribs inside the channel to enable the inner guards to fit inside the bar end plates. Trim the lower section of the inner guards to align with the bar skirt.
- 19.** Use the machine screws supplied to secure the numberplate to the bar. Use the scotchlocks supplied to join the bar indicators into the vehicle turn/indicator wiring harness.
- 20.** Please ensure that the mounts do not rub or chafe against any components on the vehicle (eg. radiator hoses, heater hoses, electrical wiring/looms, air conditioning lines, body panels, brake lines, etc).

FTOY105

PAGE 5 OF 5

**BOLT KIT SUPPLIED >**

- 2 - chassis mount (TP41A-88K)(left and right hand)
- 1 - air duct plate (TP30-88K)
- 4 - spacer plate (TP41B-88K)
- 2 - mount brace (stamped TP42-88K)
- 1 - grille support bracket (stamped TP54-88K)
- 2 - headlight support bracket (stamped TP50-88K)(left and right hand)
- 6 - 1/2" UNC x 1 1/2" bolt (90427)
- 6 - 1/2" UNC nut (90428)
- 12 - 1/2" x 1-1/4" flat washer (90623)
- 6 - 1/2" x 3/16" x 1/8" medium spring lock washer (90617)
- 4 - M10 x 1.25 x 30 bolt (90564)
- 6 - 3/8" x 1" x 14g flat washer (90630)
- 4 - 3/8" x 1/8" x 3/32" medium spring lock washer (90615)
- 2 - M8 x 1.25 x 20 bolt (90552)
- 8 - 5/16" x 1/8" x 3/32" medium spring lock washer (90614)
- 6 - 5/16" UNC x 1" bolt (90500)
- 6 - 5/16" UNC nut (90589)
- 12 - 5/16" x 3/4" x 18G flat washer (90628)
- 8 - M6 x 1.0 nut (90584)
- 8 - 1/4" x 5/8" x 18g flat washer (90626)
- 8 - 1/4" x 3/32" x 1/16" medium spring lock washer (90613)
- 7 - M5 x 0.8 x 20 pan head screw (90688)
- 7 - M5 x 0.8 nyloc nut (90604)
- 12 - 3/16" x 1/2" x 20G flat washer (90625)
- 6 - scotchlock (90419)
- 2 - wing extension (left and right hand)
- 1 - LH wing extension gasket (90372)
- 1 - RH wing extension gasket (90373)

**BOLT KIT FACTORY FITTED >**

Indicator/Park Light Assembly (Position 8)(80101)

- 1 - Indicator/Park Light LH Hella (90374)
- 1 - Indicator/Park Light RH Hella (90375)
- 2 - Indicator Recess (90764)
- 2 - Indicator Swivel (90377)
- 4 - Bridge (90781)
- 4 - Plastic Screw Insert (F1031)(90665)
- 2 - Screw Button Head PR 'S' Point 8g-15x16 Corshield (Recess/Swivel)(90943)
- 4 - Screw Pan Washer PR 'S' Point 8g-12x20 Corshield (Recess/Bridge)(90944)
  
- 2 - MK3 T15 Bumperette (90912)
- 2 - 14-10x42 Hex W/F SDS Zinc/Gold (90433)
- 2 - Bumperette Plug (90431)
- 2 - Bumperette Plug TJM Sticker (90432)
- 3 - Winch slot square cover (90777)

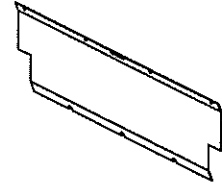

AIR DUCT PLATE (TP30-88K)

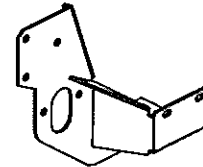

CHASSIS MOUNT  
(TP41A-88K)(LHS)

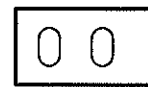

SPACER PLATE  
(TP41B-88K)

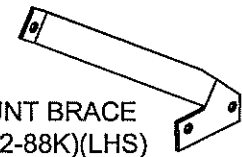

MOUNT BRACE  
(TP42-88K)(LHS)



HEADLIGHT SUPPORT  
BRACKET (TP50-88K)



GRILLE SUPPORT  
BRACKET (TP54-88K)